

Ordinary Council Meeting

Minutes | 31st October 2024

Disclaimer

Members of the public should note that in any discussion regarding any planning or other application that any statement or intimation of approval made by any member or officer of the Shire of Quairading during the course of any meeting is not intended to be and is not to be taken as notice of approval from the Shire of Quairading. No action should be taken on any item discussed at a Council meeting prior to written advice on the resolution of the Council being received.

Any plans or documents contained in this document may be subject to copyright law provisions (*Copyright Act 1968*, as amended) and the express permission of the copyright owner(s) should be sought prior to the reproduction.

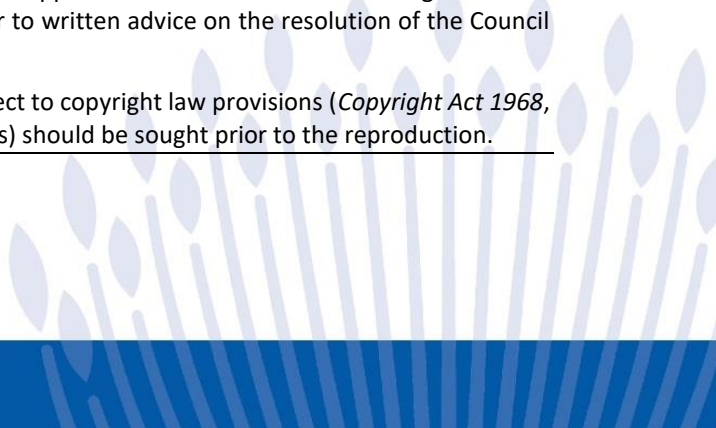

CONTENTS

ITEM 1 OPENING & ANNOUNCEMENTS 4

ITEM 2 ATTENDANCE AND APOLOGIES 4

ITEM 3 PUBLIC QUESTIONS 5
No matters for consideration

ITEM 4 DEPUTATIONS/PRESENTATIONS/SUBMISSIONS/PETITIONS 5
No matters for consideration

ITEM 5 APPLICATIONS FOR LEAVE OF ABSENCE 5
No matters for consideration

ITEM 6 DECLARATIONS OF INTEREST 5
 6.1 Ms Jen Green – Item 12.4 – Indirect Financial 5

ITEM 7 CONFIRMATION OF MINUTES AND BUSINESS ARISING 6
 7.1 Confirmation of Minutes: Ordinary Council Meeting – 26 September 2024..... 6
 BUSINESS ARISING 6

ITEM 8 RECEIVAL OF COMMITTEE MEETING MINUTES (NO RECOMMENDATIONS) 6
No matters for consideration

**ITEM 9 RECOMMENDATIONS FROM COMMITTEE MEETINGS FOR COUNCIL
 CONSIDERATION 7**

9.1 Bushfire Advisory Committee Meeting – 15 October 2024 7

9.1.1 Appointment of Chief Bush Fire Control Officer 8

9.1.2 Appointment of Fire Control Officers..... 9

9.1.3 Appointment of Fire Weather Monitors 10

9.1.4 Restricted Burning Period/Prohibited Burning Period 11

ITEM 10 MATTERS FOR CONSIDERATION – BUILDING & TOWN PLANNING 12
No matters for consideration

ITEM 11 MATTERS FOR CONSIDERATION – FINANCE & AUDIT 12

11.1 Monthly Financial Statements - September 2024 12

11.2 Accounts for Payment - September 2024 46

11.3 Purchase of Hospital Auxiliary Community Car..... 84

ITEM 12 MATTERS FOR CONSIDERATION – GOVERNANCE & ADMINISTRATION 93

12.1 Council meeting dates for the 2025 calendar year 93

12.2 Voluntary Alcohol Self Testing Policy - Biennial Review 97

12.3 Urban and Rural Street Addressing Policy - Biennial Review 107

12.4 School for Pool Program..... 115

12.5	Council committees, advisory groups and delegate appointments	119
ITEM 13	MATTERS FOR CONSIDERATION – HEALTH & BUILDING	123
	<i>No matters for consideration</i>	
ITEM 14	MATTERS FOR CONSIDERATION – WORKS & SERVICES.....	123
14.1	Update on Works & Services Programme.....	123
14.2	Finalise Procurement, Request for Tender for Road Grader	134
ITEM 15	MATTERS FOR CONSIDERATION - WORK, HEALTH & SAFETY	214
	<i>No matters for consideration</i>	
ITEM 16	URGENT COUNCILLOR’S BUSINESS.....	214
ITEM 17	CONFIDENTIAL ITEMS	214
	<i>No matters for consideration</i>	
ITEM 18	NEXT MEETING DATE.....	214
ITEM 19	CLOSURE	214

SHIRE OF QUAIRADING

The Ordinary Council Meeting Minutes of Meeting held on 31st October 2024 commencing at 2.00pm.

ITEM 1 OPENING & ANNOUNCEMENTS

The Shire President opened the Meeting at 2.00 pm.

“Before we start our meeting, I would like to acknowledge that we are meeting on Noongar/Ballardong land. We pay respect to the original custodians of the land...past, present and future. I welcome you all here today for this meeting.”

ITEM 2 ATTENDANCE AND APOLOGIES

Councillors

Cr JN Haythornthwaite	Shire President
Cr TJ Stacey	Deputy Shire President
Cr BR Cowcill	
Cr RC Faltyn	
Cr EV Gom	
Cr JC Hayes	
Cr JR Hippisley	

Council Officers

Ms NJ Ness	Chief Executive Officer
Ms SE Caporn	Executive Manager, Works & Services
Ms J Green	Executive Manager, Economic Development
Ms M Haeusler	Executive Officer

Observers/Visitor

Nil

Apologies

Ms T Brown	Executive Manager, Corporate Services
------------	---------------------------------------

Leave of Absence Previously Granted

Nil

ITEM 3 PUBLIC QUESTIONS

No matters for consideration

ITEM 4 DEPUTATIONS/PRESENTATIONS/SUBMISSIONS/PETITIONS

No matters for consideration

ITEM 5 APPLICATIONS FOR LEAVE OF ABSENCE

No matters for consideration

ITEM 6 DECLARATIONS OF INTEREST

6.1 Ms Jen Green – Item 12.4 – Indirect Financial

Ms Jen Green declared an indirect financial interest in relation to item 12.4 School for Pool – Very likely to benefit if passed, by way of free pool entry for my children.

COMMENTS

Cr Stacey enquired about the reason why a non-voting staff member was declaring an interest. The EO explained that the staff member had declared the interest as the author of the relevant agenda item.

ITEM 7 CONFIRMATION OF MINUTES AND BUSINESS ARISING

7.1 Confirmation of Minutes: Ordinary Council Meeting – 26 September 2024

RESOLUTION: OCM 055-24/25

Moved: Cr BR Cowcill

Seconded: Cr RC Faltyn

That the Minutes of the Ordinary Council Meeting held on the 26 September 2024 be confirmed as a true and accurate record.

FOR: Crs JN Haythornthwaite, TJ Stacey, BR Cowcill, RC Faltyn, EV Gom, JC Hayes and JR Hippisley

AGAINST: Nil

CARRIED 7/0

BUSINESS ARISING

Nil

ITEM 8 RECEIVAL OF COMMITTEE MEETING MINUTES (NO RECOMMENDATIONS)

No matters for consideration

ITEM 9 RECOMMENDATIONS FROM COMMITTEE MEETINGS FOR COUNCIL CONSIDERATION**9.1 Bushfire Advisory Committee Meeting – 15 October 2024****Responsible Officer** Natalie Ness, Chief Executive Officer**Reporting Officer** Marion Haeusler, Executive Officer**Attachments** Nil**Voting Requirements** Simple Majority**Disclosure of Interest** Reporting Officer: Nil

Responsible Officer: Nil

RESOLUTION: OCM 056-24/25

Moved: Cr JR Hippisley

Seconded: Cr JC Hayes

That Council receive the minutes of the Bushfire Advisory Committee for its meeting on 15 October 2024.

FOR: Crs JN Haythornthwaite, TJ Stacey, BR Cowcill, RC Faltyn, EV Gom, JC Hayes and JR Hippisley

AGAINST: Nil

CARRIED 7/0

The minutes for the Bush Fire Advisory Committee Meeting were provided to Council under separate cover. The minutes can be found on Council's website: www.quairading.wa.gov.au.

9.1.1 Appointment of Chief Bush Fire Control Officer

Responsible Officer Natalie Ness, Chief Executive Officer

Reporting Officer Marion Haeusler, Executive Officer

Attachments Nil

Voting Requirements Simple Majority

Disclosure of Interest Reporting Officer: Nil
Responsible Officer: Nil

RESOLUTION: OCM 057-24/25

Moved: Cr TJ Stacey
Seconded: Cr BR Cowcill

COMMITTEE RESOLUTION: BFAC 002-24/25

That the Bush Fire Advisory Committee recommend to Council that Nigel Gelmi be appointed as Chief Bush Fire Control Officer until October 2025.

FOR: Crs JN Haythornthwaite, TJ Stacey, BR Cowcill, RC Faltyn, EV Gom, JC Hayes and JR Hippisley

AGAINST: Nil

CARRIED 7/0

IN BRIEF

Mr T Hadlow nominated Mr Nigel Gelmi as Chief Bush Fire Control Officer.
Mr L Johnston seconded.
Mr N Gelmi accepted the nomination.

9.1.2 Appointment of Fire Control Officers

Responsible Officer	Natalie Ness, Chief Executive Officer
Reporting Officer	Marion Haeusler, Executive Officer
Attachments	Nil
Voting Requirements	Simple Majority
Disclosure of Interest	Reporting Officer: Nil Responsible Officer: Nil

RESOLUTION: OCM 058-24/25

Moved: Cr RC Faltyn
 Seconded: Cr JR Hippisley

COMMITTEE RESOLUTION: BFAC 003-24/25

That the Bush Fire Advisory Committee recommend to Council that the following persons, subject to their acceptance, be appointed Fire Control Officers for the Shire of Quairading until October 2025:

Mr N Gelmi, Mr L Johnston, Mr M Davies, Mr M Peacock, Mr H Harris, Mr B Wilson, Mr T Hadlow, Mr G Mills, Mr T Mills, Mr G Hughes, Mr M Richards.

FOR: Crs JN Haythornthwaite, TJ Stacey, BR Cowcill, RC Faltyn, EV Gom, JC Hayes and JR Hippisley

AGAINST: Nil

CARRIED 7/0

IN BRIEF

Mr B Wilson nominated all who had been appointed Fire Control Officers in the previous year and M Peacock and H Harris.

Mr Harris seconded the nominations.

All present nominees accepted.

9.1.3 Appointment of Fire Weather Monitors

Responsible Officer Natalie Ness, Chief Executive Officer
Reporting Officer Marion Haeusler, Executive Officer
Attachments Nil
Voting Requirements Simple Majority
Disclosure of Interest Reporting Officer: Nil
 Responsible Officer: Nil

RESOLUTION: OCM 059-24/25

Moved: Cr BR Cowcill
 Seconded: Cr TJ Stacey

COMMITTEE RESOLUTION: BFAC 004-24/25

That the Bush Fire Advisory Committee recommend to Council that the following persons be appointed as Fire Weather Advisors until October 2025:

Town	Sarah Caporn, CESM (when available)
North West Area	Mitch Davies
South West Area	Todd Mills
South East Area	Greg Hughes
North East Area	Ben Wilson
Advisor	Nigel Gelmi

FOR: Crs JN Haythornthwaite, TJ Stacey, BR Cowcill, RC Faltyn, EV Gom, JC Hayes and JR Hippisley

AGAINST: Nil

CARRIED 7/0

IN BRIEF

The Role of the Fire Weather Monitors is to keep an eye on current weather conditions at the request of the Chief Bush Fire Control Officer, or Deputy in the Chiefs absence in order to decide whether a harvest vehicle movement and hot works ban will be implemented at any given time on a day that is required should the weather conditions warrant it.

9.1.4 Restricted Burning Period/Prohibited Burning Period

Responsible Officer	Natalie Ness, Chief Executive Officer
Reporting Officer	Marion Haeusler, Executive Officer
Attachments	Nil
Voting Requirements	Simple Majority
Disclosure of Interest	Reporting Officer: Nil Responsible Officer: Nil

RESOLUTION: OCM 060-24/25

Moved: Cr JR Hippisley
 Seconded: Cr JC Hayes

COMMITTEE RESOLUTION: BFAC 005-24/25

That the Bush Fire Advisory Committee recommend to Council that the Prohibited Burning Period commence on 18th October 2024.

FOR: Crs JN Haythornthwaite, TJ Stacey, BR Cowcill, RC Faltyn, EV Gom, JC Hayes and JR Hippisley

AGAINST: Nil

CARRIED 7/0

IN BRIEF

The following dates have been made public to the community with the Shire’s Fire Break Notice 2024/25:

Restricted Burning Period:

- 16th October 2024 – 31st October 2024

Prohibited Burning Period:

- 1st November 2024 – 28th February 2025

Restricted Burning Period:

- 28th February 2025 – 29th March 2025

It was discussed that current weather and ground conditions in addition to high fuel load warrant a cautious approach to burning restrictions. The Committee agreed to modify the previously advertised restriction dates to the following:

Restricted Burning Period:

- 16th October 2024 – 17th October 2024

Prohibited Burning Period:

- 18th October 2024 – 28th February 2025

Restricted Burning Period:

- 28th February 2025 – 29th March 2025

Shire to circulate messages regarding Prohibited Burning Period for Easter and Anzac Day.

COMMENTS

Cr Stacey recalled that the BFAC intended to move the start of the prohibited burning period forward to the 16th of October. Cr Haythornthwaite explained that although that was the intention at the meeting, the CESM had reminded that the start date could be changed at a maximum of fourteen days in either direction.

ITEM 10 MATTERS FOR CONSIDERATION – BUILDING & TOWN PLANNING

No matters for consideration

ITEM 11 MATTERS FOR CONSIDERATION – FINANCE & AUDIT

11.1 Monthly Financial Statements - September 2024

Responsible Officer Natalie Ness, Chief Executive Officer

Reporting Officer Tricia Brown, Executive Manager, Corporate Services

Attachments 1. Attachment (i) Monthly Financial Report September 2024 [↓](#) 

Voting Requirements Simple Majority

Disclosure of Interest Reporting Officer: Nil

Responsible Officer: Nil

RESOLUTION: OCM 061-24/25

Moved: Cr JR Hippisley

Seconded: Cr BR Cowcill

That Council receive the monthly Financial Statements for the periods ending:

- 30 September 2024 - Attachment (i)

FOR: Crs JN Haythornthwaite, TJ Stacey, BR Cowcill, RC Faltyn, EV Gom, JC Hayes and JR Hippisley

AGAINST: Nil

CARRIED 7/0

IN BRIEF

- Monthly financial statements for the period ending 30 September 2024 attached
- Depreciation has been calculated for the months of July 2023 to June 2024.
- Admin Allocations have been run for the months of July 2024 to September 2024.

MATTER FOR CONSIDERATION

To receive the monthly financial report and statements.

BACKGROUND

The Statement of Financial Activity, a similar report to the Rate Setting Statement, is required to be produced monthly in accordance with the Local Government (Financial Management) Regulation 1996. This financial report is unique to local government drawing information from other reports to include operating and capital revenue and expenditure, transfers to reserves and loan funding.

The ongoing impact of COVID-19 in conjunction with other international events, such as war, continue to cause uncertainty and supply shortages around the world, with significant impact on world economic activities. It has resulted in steep rises in inflation worldwide, including Australia.

The monthly CPI indicator rose 2.7% in the 12 months to August 2024.

	Jun 23 to Jun 24 % change	Jul 23 to Jul 24 % change	Aug 23 to Aug 24 % change
All groups monthly CPI	3.8	3.5	2.7

To curb the high inflation the Reserve Bank of Australia (RBA) have, in the last financial year, announced consecutive increases in the cash rate. As per the media release statement by the RBA 6th August 2024 the cash rate will remain unchanged at 4.35 %. The current RBA Inflation rate has remained the same at 3.8% as per the July month indicator.

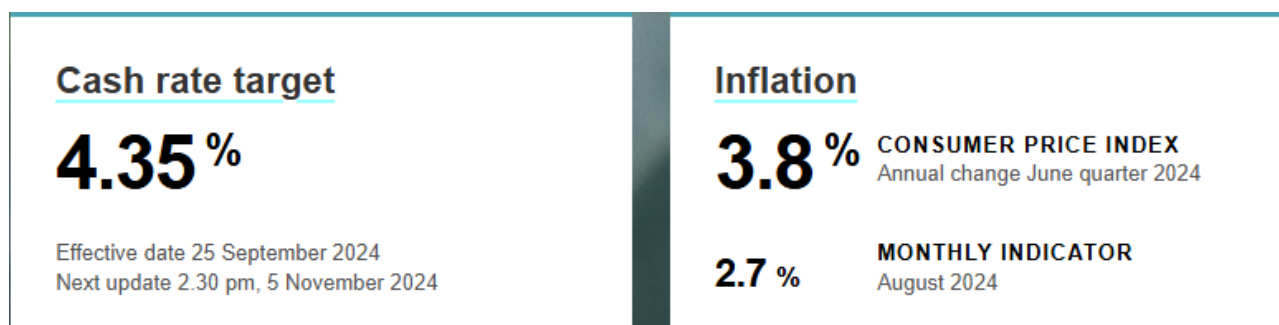

In framing the 2024/2025, the Shire has taken into consideration the economic environment and sustainability of its services into the future.

Regulation 34(5) of the Local Government (Financial Management) Regulations 1996, requires each local government to present a Statement of Financial Activity that reports on income and expenditure as set out in the Annual Budget. In addition, regulation 34(5) stipulates for a local government to adopt a percentage or value to report on material variances between budgeted and actual results. The 2024/25 budget determines the variance analysis for significant amounts of \$10,000 and 10% for the financial year.

STATUTORY ENVIRONMENT

Australian Accounting Standards

Local Government (Financial Management) Regulations 1996

Local Government Act 1995

Regulation 34 requires local governments to report monthly, although it is much more prescriptive as to what is required, and its intention is to establish a minimum standard across the industry.

The Regulation requires the local government to prepare each month a statement of financial activity and the statement is intended to report on the sources and application of funds and highlighting variances to budget for the month in question.

POLICY IMPLICATIONS

Significant Accounting Policies

FINANCIAL IMPLICATIONS

Council adopted the 2024/25 Budget at the OCM 29th August 2024.

ALIGNMENT WITH STRATEGIC PRIORITIES

- 5.3 **Governance & Leadership:** Provide informed and transparent decision making that, meets our legal obligations, and the needs of our diverse community
- 5.4 **Governance & Leadership:** Implement systems and processes that meet legislative and audit obligations

CONSULTATION

Nil

RISK MANAGEMENT PRIORITIES

This report addresses the following identified Strategic Risk Management Priorities:

Financial misconduct by (a) a Shire employee, and (b) an executive/office holder results in financial, legal and/or reputational damage.

Low rate-base results in an inability to keep up with inflation.

RISK ASSESSMENT

	Option 1
Financial	<i>Low 24-25 Budget Adopted by Council.</i>
Health	Low
Reputation	Low
Operations	Low
Natural Environment	Low

	Consequence				
Likelihood	Insignificant	Minor	Moderate	Major	Critical
Rare	LOW Accept the risk Routine management	LOW Accept the risk Routine management	LOW Accept the risk Routine management	MEDIUM Specific responsibility and treatment	HIGH Quarterly senior management review
Unlikely	LOW Accept the risk Routine management	LOW Accept the risk Routine management	MEDIUM Specific responsibility and treatment	MEDIUM Specific responsibility and treatment	HIGH Quarterly senior management review
Possible	LOW Accept the risk Routine management	MEDIUM Specific responsibility and treatment	MEDIUM Specific responsibility and treatment	HIGH Quarterly senior management review	HIGH Quarterly senior management review
Likely	MEDIUM Specific responsibility and treatment	MEDIUM Specific responsibility and treatment	HIGH Quarterly senior management review	HIGH Quarterly senior management review	EXTREME Monthly senior management review
Almost certain	MEDIUM Specific responsibility and treatment	MEDIUM Specific responsibility and treatment	HIGH Quarterly senior management review	EXTREME Monthly senior management review	EXTREME Monthly senior management review

COMMENT

The September 2024 Monthly Financial Statements reflects the adopted 2024/2025 Budget.

The current aged creditors balance as of 30 September 2024 is \$181,901.48. This is made up of current invoices, one account received late and one 30 day account .

The current aged debtors balance as of 30 September 2024 is \$201,167.98 with the majority of the balance being several small Invoices. Two large invoices being recognition of revenue to be received from the ATO which will be negated via a payment of our Business Activity Statement in October. One large main roads invoice is outstanding at 90 days however was received in October.

COMMENTS

Cr Hippisley enquired whether it was possible to add a breakdown of the monthly financials regarding the Quairading Memorial Pool in a similar way as the Caravan Park financials are being reported on. Cr Haythornthwaite asked the CEO to pass the request on to the EMCS



SHIRE OF QUAIRADING
MONTHLY FINANCIAL REPORT
(Containing the Statement of Financial Activity)
For the Period Ended 30 September 2024

LOCAL GOVERNMENT ACT 1995
LOCAL GOVERNMENT (FINANCIAL MANAGEMENT) REGULATIONS 1996

TABLE OF CONTENTS

Monthly Summary Information

Key Terms and Descriptions - Statutory Reporting Programs

Statement of Financial Activity by Program

Key Terms and Descriptions - Nature Descriptions

Statement of Financial Activity by Nature

Statement of Financial Position

Note 1 Adjusted Net Current Assets

Note 2 Cash and Financial Assets

Note 3 Receivables

Note 4 Other Current Assets

Note 5 Payables

Note 6 Rating Revenue

Note 7 Disposal of Assets

Note 8 Capital Acquisitions

Note 9 Borrowings

Note 10 Reserves

Note 11 Other Current Liabilities

Note 12 Grants and Contributions

Note 13 Capital Grants and Contributions

Note 14 Bonds & Deposits and Trust Fund

Note 15 Explanation of Material Variances

Note 16 Budget Amendments

Note 17 Caravan Park

THIS PAGE INTENTIONALLY LEFT BLANK

**SHIRE OF QUAIRADING
MONTHLY FINANCIAL REPORT
FOR THE PERIOD ENDED 30 SEPTEMBER 2024**

KEY INFORMATION

Items of Significance

The material variance adopted by the Shire for the 2023/24 year is \$10,000 and 10%. The following selected items have been highlighted due to the amount of the variance to the budget or due to the nature of the revenue/expenditure. A full listing and explanation of all items considered of significant/material variance is disclosed in Note 15.

	% Collected / Completed	Amended Annual Budget	Amended YTD Budget	YTD Actual	Variance (Under)/Over
Significant Projects					
Grants, Subsidies and Contributions					
Grants, Subsidies and Contributions	1%	600,874	197,574	4,780	(192,794)
Capital Grants, Subsidies and Contributions	-1%	2,066,381	299,708	(28,607)	(328,315)
	-1%	2,667,255	497,282	(23,827)	(521,109)
Rates Levied	99%	2,799,736	2,781,425	2,781,111	(314)

Financial Position		Prior Year 30 September 2023	Current Year 30 September 2024
Adjusted Net Current Assets	87%	\$ 4,018,089	\$ 3,510,580
Cash and Equivalent - Unrestricted	66%	\$ 1,671,163	\$ 1,098,814
Cash and Equivalent - Restricted	100%	\$ 4,093,439	\$ 4,111,639
Receivables - Rates	115%	\$ 2,195,438	\$ 2,527,459
Receivables - Other	114%	\$ 327,699	\$ 373,488
Payables	202%	\$ 284,861	\$ 576,600

% Compares current ytd actuals to prior year actuals at the same time

Note: The Statements and accompanying notes are prepared based on all transactions recorded at the time of preparation and may vary due to transactions being processed for the reporting period after the date of preparation.

**SHIRE OF QUAIRADING
MONTHLY FINANCIAL REPORT
FOR THE PERIOD ENDED 30 SEPTEMBER 2024**

SUMMARY INFORMATION

PREPARATION TIMING AND REVIEW

Date prepared: All known transactions up to 30 September 2024
Prepared by: Tricia Brown (EMCS)
Reviewed by: Natalie Ness (CEO)

BASIS OF PREPARATION

REPORT PURPOSE

This report is prepared to meet the requirements of Local Government (Financial Management) Regulations 1996, Regulation 34 . Note: The Statements and accompanying notes are prepared based on all transactions recorded at the time of preparation and may vary due to transactions being processed for the reporting period after the date of preparation.

BASIS OF ACCOUNTING

This statement comprises a special purpose financial report which has been prepared in accordance with Australian Accounting Standards (as they apply to local governments and not-for-profit entities), Australian Accounting Interpretations, other authoritative pronouncements of the Australian Accounting Standards Board, the Local Government Act 1995 and accompanying regulations. Material accounting policies which have been adopted in the preparation of this statement are presented below and have been consistently applied unless stated otherwise. Except for cash flow and rate setting information, the report has also been prepared on the accrual basis and is based on historical costs, modified, where applicable, by the measurement at fair value of selected non-current assets, financial assets and liabilities.

THE LOCAL GOVERNMENT REPORTING ENTITY

All Funds through which the Council controls resources to carry on its functions have been included in this statement. In the process of reporting on the local government as a single unit, all transactions and balances between those funds (for example, loans and transfers between Funds) have been eliminated. All monies held in the Trust Fund are excluded from the statement, but a separate statement of those monies appears at Note 14.

SIGNIFICANT ACCOUNTING POLICES

GOODS AND SERVICES TAX

Revenues, expenses and assets are recognised net of the amount of GST, except where the amount of GST incurred is not recoverable from the Australian Taxation Office (ATO). Receivables and payables are stated inclusive of GST receivable or payable. The net amount of GST recoverable from, or payable to, the ATO is included with receivables or payables in the statement of financial position. Cash flows are presented on a gross basis. The GST components of cash flows arising from investing or financing activities which are recoverable from, or payable to, the ATO are presented as operating cash flows.

CRITICAL ACCOUNTING ESTIMATES

The preparation of a financial report in conformity with Australian Accounting Standards requires management to make judgements, estimates and assumptions that effect the application of policies and reported amounts of assets and liabilities, income and expenses. The estimates and associated assumptions are based on historical experience and various other factors that are believed to be reasonable under the circumstances; the results of which form the basis of making the judgements about carrying values of assets and liabilities that are not readily apparent from other sources. Actual results may differ from these estimates.

ROUNDING OFF FIGURES

All figures shown in this statement are rounded to the nearest dollar.

**SHIRE OF QUAIRADING
MONTHLY FINANCIAL REPORT
FOR THE PERIOD ENDED 30 SEPTEMBER 2024**

SUMMARY GRAPHS

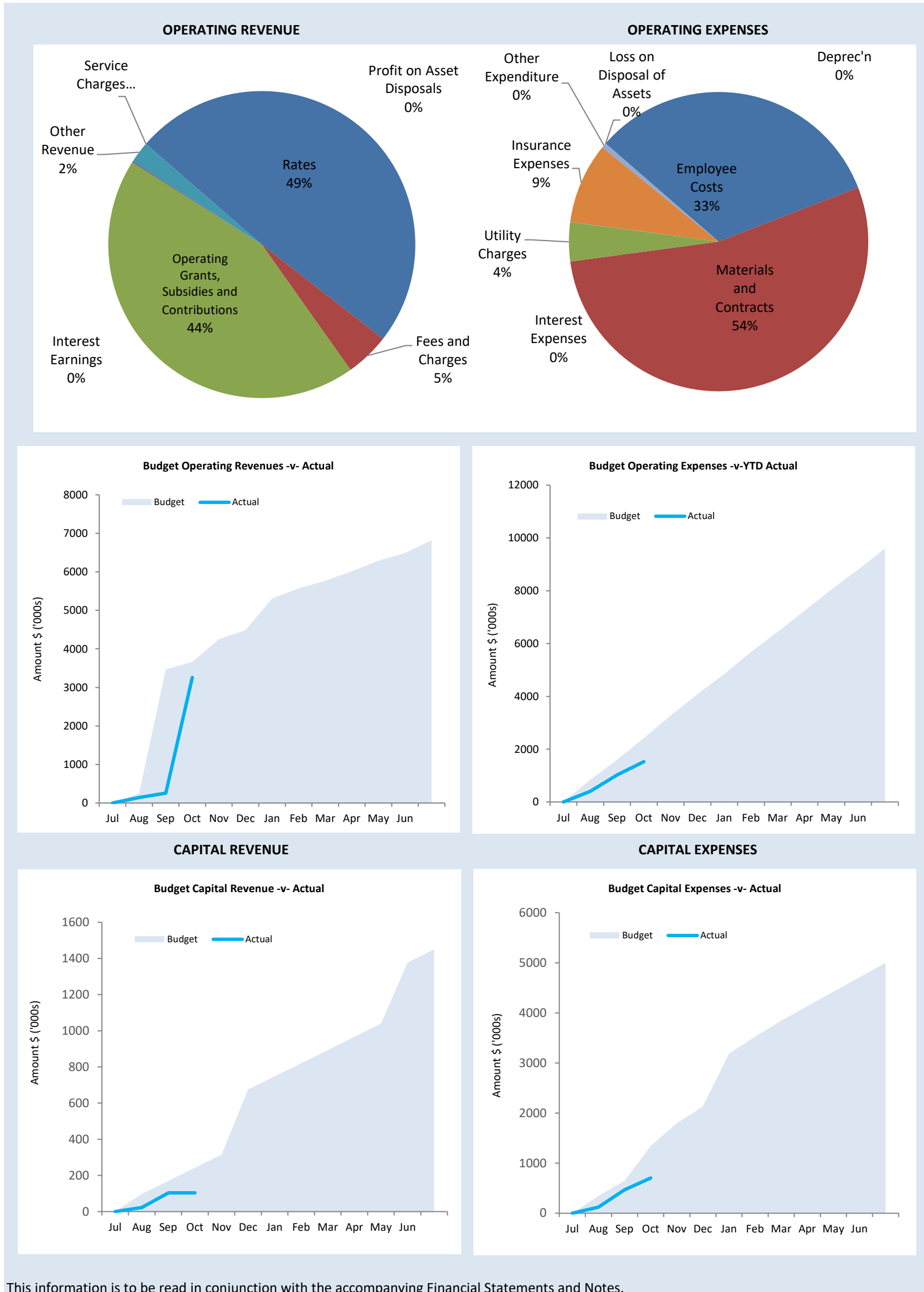

**SHIRE OF QUAIRADING
KEY TERMS AND DESCRIPTIONS
FOR THE PERIOD ENDED 30 SEPTEMBER 2024**

STATUTORY REPORTING PROGRAMS

Shire operations as disclosed in these financial statements encompass the following service orientated activities/programs.

	ACTIVITIES
<p>GOVERNANCE To provide a decision making process for the efficient allocation of scarce resources.</p>	The Governance function accumulates the costs of Members expenses and other costs of Council that relate to the tasks of assisting councillors and the Ratepayers on matters which do not concern specific Council services, being election costs; allowances and expenses of members; policy and training and audit fees.
<p>GENERAL PURPOSE FUNDING To collect revenue to allow for the provision of services that are not fully funded by specific fees and charges.</p>	Rates, general purpose government grants and interest revenue.
<p>LAW, ORDER, PUBLIC SAFETY To provide services to help ensure a safer and environmentally conscious community.</p>	Supervision of local laws, fire control which covers the maintenance of bushfire equipment and insurance; animal control and a shared community emergency services manager.
<p>HEALTH To provide an operational framework for environmental and community health.</p>	Health inspections, food quality control, pest control and operation of the medical centre.
<p>EDUCATION AND WELFARE To provide services to disadvantaged persons, the elderly, children and youth.</p>	Operation and maintenance of the Little Rainmakers Childcare Centre building, Arthur Kelly Village and minor in-kind association with the Fail Aged Lodge, Youth programme and Quairading Youth Centre.
<p>HOUSING To provide and maintain housing.</p>	Maintenance of housing rented to staff and non staff.
<p>COMMUNITY AMENITIES Provide services required by the community.</p>	Rubbish and recycling services and administration of Town Planning Scheme and Heritage services. Community bus service, maintenance of cemeteries, public conveniences and environmental services.
<p>RECREATION AND CULTURE To establish and effectively manage infrastructure and resources which will help the social wellbeing of the community.</p>	Maintenance of Halls, Swimming Pool, community buildings and various reserves and library.
<p>TRANSPORT To provide safe, effective and efficient transport services to the community.</p>	Construction and maintenance of roads, drainage works, footpaths, parking facilities and cleaning of streets. Natural disaster road and bridge repairs. On-line licensing centre for Department of Transport. Maintenance of the Airstrip.
<p>ECONOMIC SERVICES To help promote the Shire Quairading and its economic wellbeing.</p>	Community development, operation of caravan park and short stay accommodation, tourism and townscape, control of noxious weeds/plants. Pests and building control, community gym and building control.
<p>OTHER PROPERTY AND SERVICES To monitor and control the Shire of Quairading overheads.</p>	Public works overheads, plant operating costs, allocation of salaries and wages. Operation of electrical services and private works.

**SHIRE OF QUAIRADING
STATEMENT OF FINANCIAL ACTIVITY BY PROGRAM
FOR THE PERIOD ENDED 30 SEPTEMBER 2024**

BY PROGRAM

Note	Adopted	Amended	Amended YTD	YTD	Var. \$	Var. %	Var.	Significant
	Annual Budget	Annual Budget (d)	Budget (a)	Actual (b)	(b)-(a)	(b)-(a)/(a)	▲▼	Var. S
	\$	\$	\$	\$	\$	%		
OPERATING ACTIVITIES								
Revenue from operating activities								
Governance	0	0	0	0	0			
General Purpose Funding - Rates	6 2,799,736	2,799,736	2,781,425	2,781,111	(314)	(0%)	▼	
General Purpose Funding - Other	481,956	481,956	44,448	10,742	(33,706)	(76%)	▼	S
Law, Order and Public Safety	286,992	286,992	59,546	28,823	(30,723)	(52%)	▼	S
Health	500	500	123	(1)	(124)	(101%)	▼	
Education and Welfare	72,712	72,712	18,141	19,760	1,619	9%	▲	
Housing	169,464	169,464	42,303	46,364	4,061	10%	▲	
Community Amenities	234,046	234,046	57,966	158,317	100,351	173%	▲	S
Recreation and Culture	30,150	30,150	3,192	1,149	(2,043)	(64%)	▼	
Transport	304,769	304,769	211,578	7,133	(204,445)	(97%)	▼	S
Economic Services	326,600	326,600	130,358	129,306	(1,052)	(1%)	▼	
Other Property and Services	50,100	50,100	12,514	1,093	(11,421)	(91%)	▼	S
	4,757,025	4,757,025	3,361,594	3,183,797				
Expenditure from operating activities								
Governance	(688,725)	(688,725)	(167,277)	(80,089)	87,188	52%	▲	S
General Purpose Funding	(120,484)	(120,484)	(30,371)	(14,011)	16,360	54%	▲	S
Law, Order and Public Safety	(611,515)	(611,515)	(152,765)	(76,452)	76,313	50%	▲	S
Health	(547,158)	(547,158)	(136,707)	(210,098)	(73,391)	(54%)	▼	S
Education and Welfare	(365,867)	(365,867)	(90,712)	(45,270)	45,442	50%	▲	S
Housing	(255,064)	(255,064)	(63,514)	(48,181)	15,333	24%	▲	S
Community Amenities	(1,149,300)	(1,149,300)	(287,157)	(142,882)	144,275	50%	▲	S
Recreation and Culture	(1,316,934)	(1,316,934)	(301,831)	(142,939)	158,892	53%	▲	S
Transport	(3,468,184)	(3,468,184)	(866,635)	(351,704)	514,931	59%	▲	S
Economic Services	(1,028,479)	(1,028,479)	(242,531)	(88,473)	154,058	64%	▲	S
Other Property and Services	(47,502)	(47,502)	(72,807)	(325,838)	(253,031)	(348%)	▼	S
	(9,599,212)	(9,599,212)	(2,412,307)	(1,525,936)				
Operating activities excluded from budget								
Add back Depreciation	3,448,062	3,448,062	861,648	0	(861,648)	(100%)	▼	S
Adjust (Profit)/Loss on Asset Disposal	7 315,083	315,083	78,180	0	(78,180)	(100%)	▼	S
Movement in Leave Reserve (Added Back)	4,739	4,739	4,739	0	(4,739)	(100%)	▼	
Movement in Deferred Pensioner Rates/ESL	0	0	0	0	0			
Movement in Employee Benefit Provisions	0	0	0	0	0			
Rounding Adjustments	0	0	0	0	0			
Movement Due to Changes in Accounting Standards	0	0	0	0	0			
Fair value adjustments to financial assets at fair value through profit and loss	0	0	0	0	0			
Loss on Asset Revaluation	0	0	0	0	0			
Adjustment in Fixed Assets	0	0	0	0	0			
	3,767,884	3,767,884	944,567	0				
Amount attributable to operating activities	(1,074,304)	(1,074,304)	1,893,854	1,657,861				
INVESTING ACTIVITIES								
Inflows from investing activities								
Capital Grants, Subsidies and Contributions	13 2,066,381	2,066,381	299,708	(28,607)	(328,315)	(110%)	▼	S
Proceeds from Disposal of Assets	7 920,000	920,000	242,499	103,636	(138,863)	(57%)	▼	S
Proceeds from financial assets at amortised cost - self supporting loans	0	0	0	0	0			
	2,986,381	2,986,381	542,207	75,029				
Outflows from investing activities								
Land Held for Resale	8 (50,000)	(50,000)	(12,504)	0	12,504	100%	▲	S
Land and Buildings	8 (751,494)	(751,494)	(201,396)	(76,678)	124,718	62%	▲	S
Plant and Equipment	8 (1,373,057)	(1,373,057)	(464,654)	(484,500)	(19,846)	(4%)	▼	
Furniture and Equipment	8 (15,000)	(15,000)	(3,750)	0	3,750	100%	▲	
Infrastructure Assets - Roads	8 (1,859,924)	(1,859,924)	(431,913)	(60,900)	371,013	86%	▲	S
Infrastructure Assets - Drainage	8 0	0	0	0	0			
Infrastructure Assets - Footpaths	8 (5,500)	(5,500)	(1,374)	(5,500)	(4,126)	(300%)	▼	
Infrastructure Assets - Other	8 (553,081)	(553,081)	(129,504)	(47,857)	81,647	63%	▲	S
Infrastructure Assets - Bridges	8 (20,000)	(20,000)	(4,998)	(20,000)	(15,002)	(300%)	▼	S
Payments for financial assets at amortised cost - self supporting loans	0	0	0	0	0			
	(4,628,055)	(4,628,055)	(1,250,093)	(695,435)				
Amount attributable to investing activities	(1,641,675)	(1,641,675)	(707,886)	(620,406)				
FINANCING ACTIVITIES								
Inflows from financing activities								
Proceeds from new borrowings	9 0	0	0	0	0			
Transfer from Reserves	10 530,000	530,000	0	0	0			
Transfer from Restricted Cash - Other	0	0	0	0	0			
	530,000	530,000	0	0				
Outflows from financing activities								
Repayment of borrowings	9 (67,898)	(67,898)	(16,965)	(7,466)	9,499	56%	▲	
Payments for principal portion of lease liabilities	9 (29,925)	(29,925)	(7,478)	0	7,478	100%	▲	
Transfer to Restricted Cash - Other	0	0	0	0	0			
Transfer to Reserves	10 (275,000)	(275,000)	(68,751)	0	68,751	100%	▲	S
	(372,823)	(372,823)	(93,194)	(7,466)				
Amount attributable to financing activities	157,177	157,177	(93,194)	(7,466)				
MOVEMENT IN SURPLUS OR DEFICIT								
Surplus or deficit at the start of the financial year	1 2,583,335	2,583,335	2,583,335	2,480,591	(102,744)	(4%)	▼	
Amount attributable to operating activities	(1,074,304)	(1,074,304)	1,893,854	1,657,861	(235,994)	(12%)	▼	
Amount attributable to investing activities	(1,641,675)	(1,641,675)	(707,886)	(620,406)	87,480	(12%)	▲	
Amount attributable to financing activities	157,177	157,177	(93,194)	(7,466)	85,728	(92%)	▲	
Surplus or deficit at the end of the financial year	1 24,534	24,534	3,676,109	3,510,580	(165,529)	(5%)	▼	

KEY INFORMATION

▲▼ Indicates a variance between Year to Date (YTD) Budget and YTD Actual data as per the adopted materiality threshold. Refer to Note 15 for an explanation of the reasons for the variance. The material variance adopted by Council for the 2024/25 year is \$10,000 and 10%.

This statement is to be read in conjunction with the accompanying Financial Statements and notes.

SHIRE OF QUAIRADING

KEY TERMS AND DESCRIPTIONS

FOR THE PERIOD ENDED 30 SEPTEMBER 2024

NATURE DESCRIPTIONS

REVENUE

RATES

All rates levied under the Local Government Act 1995. Includes general, differential, specific area rates, minimum rates, interim rates, back rates, ex-gratia rates, less discounts offered. Exclude administration fees, interest on instalments, interest on arrears and service charges.

OPERATING GRANTS, SUBSIDIES AND CONTRIBUTIONS

Refer to all amounts received as grants, subsidies and contributions that are not capital grants.

CAPITAL GRANTS, SUBSIDIES AND CONTRIBUTIONS

Amounts received specifically for the acquisition, construction of new or the upgrading of non-current assets paid to a local government, irrespective of whether these amounts are received as capital grants, subsidies, contributions or donations.

PROFIT ON ASSET DISPOSAL

Profit on the disposal of assets including gains on the disposal of long term investments. Losses are disclosed under the expenditure classifications.

FEES AND CHARGEES

Revenues (other than service charges) from the use of facilities and charges made for local government services, sewerage rates, rentals, hire charges, fee for service, photocopying charges, licences, sale of goods or information, fines, penalties and administration fees. Local governments may wish to disclose more detail such as rubbish collection fees, rental of property, fines and penalties, other fees and charges.

SERVICE CHARGES

Service charges imposed under Division 6 of Part 6 of the Local Government Act 1995. Regulation 54 of the Local Government (Financial Management) Regulations 1996 identifies these as television and radio broadcasting, underground electricity and neighbourhood surveillance services. Exclude rubbish removal charges. Interest and other items of a similar nature received from bank and investment accounts, interest on rate instalments, interest on rate arrears and interest on debtors.

INTEREST REVENUE

Interest and other items of a similar nature received from bank and investment accounts, interest on rate instalments, interest on rate arrears and interest on debtors.

OTHER REVENUE / INCOME

Other revenue, which can not be classified under the above headings, includes dividends, discounts, rebates etc.

EXPENSES

EMPLOYEE COSTS

All costs associate with the employment of person such as salaries, wages, allowances, benefits such as vehicle and housing, superannuation, employment expenses, removal expenses, relocation expenses, worker's compensation insurance, training costs, conferences, safety expenses, medical examinations, fringe benefit tax, etc.

MATERIALS AND CONTRACTS

All expenditures on materials, supplies and contracts not classified under other headings. These include supply of goods and materials, legal expenses, consultancy, maintenance agreements, communication expenses, advertising expenses, membership, periodicals, publications, hire expenses, rental, leases, postage and freight etc. Local governments may wish to disclose more detail such as contract services, consultancy, information technology, rental or lease expenditures.

UTILITIES (GAS, ELECTRICITY, WATER, ETC.)

Expenditures made to the respective agencies for the provision of power, gas or water. Exclude expenditures incurred for the reinstatement of roadwork on behalf of these agencies.

INSURANCE

All insurance other than worker's compensation and health benefit insurance included as a cost of employment.

LOSS ON ASSET DISPOSAL

Loss on the disposal of fixed assets.

DEPRECIATION

Depreciation expense raised on all classes of assets.

FINANCE COSTS

Interest and other costs of finance paid, including costs of finance for loan debentures, overdraft accommodation and refinancing expenses.

OTHER EXPENDITURE

Statutory fees, taxes, provision for bad debts, member's fees or State taxes. Donations and subsidies made to community groups.

SHIRE OF QUAIRADING

STATEMENT OF FINANCIAL ACTIVITY BY NATURE & TYPE
FOR THE PERIOD ENDED 30 SEPTEMBER 2024

BY NATURE

Note	Adopted Annual Budget	Amended Annual Budget	Amended YTD Budget (a)	YTD Actual (b)	Var. \$ (b)-(a)	Var. % (b)-(a)/(a)	Var. ▲▼	Significant Var. S
	\$	\$	\$	\$	\$	%		
OPERATING ACTIVITIES								
Revenue from operating activities								
Rates	6	2,799,736	2,799,736	2,781,425	2,781,111	(314)	(0%)	▼
Grants, Subsidies and Contributions	12	600,874	600,874	197,574	4,780	(192,794)	(98%)	▼ S
Fees and Charges		682,553	682,553	166,992	263,866	96,874	58%	▲ S
Service Charges		0	0	0	0	0		
Interest Revenue		152,350	152,350	38,064	7,723	(30,341)	(80%)	▼ S
Other Revenue		422,171	422,171	152,717	126,317	(26,400)	(17%)	▼ S
Profit on Disposal of Assets	7	99,341	99,341	24,822	0	(24,822)	(100%)	▼ S
Gain FV Valuation of Assets		0	0	0	0	0		
		4,757,025	4,757,025	3,361,594	3,183,797			
Expenditure from operating activities								
Employee Costs		(2,237,356)	(2,237,356)	(552,018)	(499,788)	52,230	9%	▲
Materials and Contracts		(2,861,124)	(2,861,124)	(744,553)	(820,745)	(76,192)	(10%)	▼ S
Utility Charges		(277,050)	(277,050)	(69,045)	(64,280)	4,765	7%	▲
Depreciation		(3,448,062)	(3,448,062)	(861,648)	0	861,648	100%	▲ S
Finance Costs		(7,980)	(7,980)	(1,989)	517	2,506	126%	▲
Insurance Expenses		(205,303)	(205,303)	(51,297)	(133,432)	(82,135)	(160%)	▼ S
Other Expenditure		(147,914)	(147,914)	(28,755)	(8,209)	20,546	71%	▲ S
Loss on Disposal of Assets	7	(414,424)	(414,424)	(103,002)	0	103,002	100%	▲ S
Loss FV Valuation of Assets		0	0	0	0	0		
		(9,599,212)	(9,599,213)	(2,412,307)	(1,525,936)			
Operating activities excluded from budget								
Add back Depreciation		3,448,062	3,448,062	861,648	0	(861,648)	(100%)	▼ S
Adjust (Profit)/Loss on Asset Disposal	7	315,083	315,083	78,180	0	(78,180)	(100%)	▼ S
Movement in Leave Reserve (Added Back)		4,739	4,739	4,739	0	(4,739)	(100%)	▼
Movement in Deferred Pensioner Rates/ESL		0	0	0	0	0		
Movement in Employee Benefit Provisions		0	0	0	0	0		
Rounding Adjustments		0	0	0	0	0		
Movement Due to Changes in Accounting Standards		0	0	0	0	0		
Fair value adjustments to financial assets at fair value through profit and loss		0	0	0	0	0		
Loss on Asset Revaluation		0	0	0	0	0		
Adjustment in Fixed Assets		0	0	0	0	0		
		3,767,884	3,767,884	944,567	0			
Amount attributable to operating activities		(1,074,304)	(1,074,303)	1,893,854	1,657,861			
INVESTING ACTIVITIES								
Inflows from investing activities								
Capital Grants, Subsidies and Contributions	13	2,066,381	2,066,381	299,708	(28,607)	(328,315)	(110%)	▼ S
Proceeds from Disposal of Assets	7	920,000	920,000	242,499	103,636	(138,863)	(57%)	▼ S
Proceeds from financial assets at amortised cost - self supporting loans	9	0	0	0	0	0		
		2,986,381	2,986,381	542,207	75,029			
Outflows from investing activities								
Land Held for Resale	8	(50,000)	(50,000)	(12,504)	0	12,504	(100%)	▲
Land and Buildings	8	(751,494)	(751,494)	(201,396)	(76,678)	124,718	62%	▲ S
Plant and Equipment	8	(1,373,057)	(1,373,057)	(464,654)	(484,500)	(19,846)	(4%)	▼
Furniture and Equipment	8	(15,000)	(15,000)	(3,750)	0	3,750	100%	▲
Infrastructure Assets - Roads	8	(1,859,924)	(1,859,924)	(431,913)	(60,900)	371,013	86%	▲ S
Infrastructure Assets - Drainage	8	0	0	0	0	0		
Infrastructure Assets - Footpaths	8	(5,500)	(5,500)	(1,374)	(5,500)	(4,126)	(300%)	▼
Infrastructure Assets - Other	8	(553,081)	(553,081)	(129,504)	(47,857)	81,647	63%	▲ S
Infrastructure Assets - Bridges	8	(20,000)	(20,000)	(4,998)	(20,000)	(15,002)	(300%)	▼ S
Payments for financial assets at amortised cost - self supporting loans		0	0	0	0	0		
		(4,628,055)	(4,628,055)	(1,250,093)	(695,435)			
Amount attributable to investing activities		(1,641,675)	(1,641,675)	(707,886)	(620,406)			
FINANCING ACTIVITIES								
Inflows from financing activities								
Proceeds from new borrowings		0	0	0	0	0		
Transfer from Reserves	10	530,000	530,000	0	0	0		
Transfer from Restricted Cash - Other		0	0	0	0	0		
		530,000	530,000	0	0			
Outflows from financing activities								
Repayment of borrowings	9	(67,898)	(67,898)	(16,965)	(7,466)	9,499	56%	▲
Payments for principal portion of lease liabilities	9	(29,925)	(29,925)	(7,478)	0	7,478	100%	▲
Transfer to Restricted Cash - Other		0	0	0	0	0		
Transfer to Reserves	10	(275,000)	(275,000)	(68,751)	0	68,751	100%	▲ S
		(372,823)	(372,823)	(93,194)	(7,466)			
Amount attributable to financing activities		157,177	157,177	(93,194)	(7,466)			
MOVEMENT IN SURPLUS OR DEFICIT								
Surplus or deficit at the start of the financial year	1	2,583,335	2,583,335	2,583,335	2,480,591	(102,744)	(4%)	
Amount attributable to operating activities		(1,074,304)	(1,074,303)	1,893,854	1,657,861	(235,994)	(12%)	
Amount attributable to investing activities		(1,641,675)	(1,641,675)	(707,886)	(620,406)	87,480	(12%)	
Amount attributable to financing activities		157,177	157,177	(93,194)	(7,466)	85,728	(92%)	
Surplus or deficit at the end of the financial year	1	24,534	24,534	3,676,109	3,510,580	(165,529)	(5%)	

▲▼ Indicates a variance between Year to Date (YTD) Budget and YTD Actual data as per the adopted materiality threshold.

Refer to Note 15 for an explanation of the reasons for the variance.

The material variance adopted by Council for the 2024/25 year is \$10,000 and 10%.

This statement is to be read in conjunction with the accompanying Financial Statements and notes.

**SHIRE OF QUAIRADING
STATEMENT OF FINANCIAL POSITION
FOR THE PERIOD ENDED 30 SEPTEMBER 2024**

	30-Sep-23	30-Sep-24
	\$	\$
CURRENT ASSETS		
Cash and cash equivalents	7,040,340	5,210,453
Trade and other receivables	505,826	2,900,948
Other financial assets	0	0
Inventories	188,674	221,064
Contract assets	676,569	361,891
Other assets	11,118	249
TOTAL CURRENT ASSETS	8,422,526	8,694,604
NON-CURRENT ASSETS		
Trade and other receivables	35,573	35,573
Other financial assets	83,171	83,171
Inventories	212,040	212,040
Property, plant and equipment	23,438,504	23,999,682
Infrastructure	99,707,841	99,842,098
Right-of-use assets	33,094	33,094
TOTAL NON-CURRENT ASSETS	123,510,223	124,205,658
TOTAL ASSETS	131,932,749	132,900,262
CURRENT LIABILITIES		
Trade and other payables	1,412,713	645,802
Other liabilities	238,647	247,647
Lease liabilities	11,047	11,047
Employee related provisions	176,085	176,085
TOTAL CURRENT LIABILITIES	1,906,389	1,141,012
NON-CURRENT LIABILITIES		
Lease liabilities	20,646	20,646
Borrowings	209,720	209,720
Employee related provisions	35,582	35,582
TOTAL NON-CURRENT LIABILITIES	265,948	265,948
TOTAL LIABILITIES	2,172,338	1,406,960
NET ASSETS	129,760,412	131,493,302
EQUITY		
Retained surplus	42,006,465	43,739,355
Reserve accounts	4,111,639	4,111,639
Revaluation surplus	83,642,307	83,642,307
TOTAL EQUITY	129,760,412	131,493,302

This statement is to be read in conjunction with the accompanying notes.

SHIRE OF QUAIRADING

NOTES TO THE STATEMENT OF FINANCIAL ACTIVITY
FOR THE PERIOD ENDED 30 SEPTEMBER 2024

OPERATING ACTIVITIES

NOTE 1

ADJUSTED NET CURRENT ASSETS

Adjusted Net Current Assets	Note	Last Years Closing 30/06/2024	This Time Last Year 30/09/2023	Year to Date Actual 30/09/2024
		\$	\$	\$
Current Assets				
Cash Unrestricted	2	2,928,701	1,671,163	1,098,814
Cash Restricted - Reserves	2	4,111,639	4,093,439	4,111,639
Cash Restricted - Bonds & Deposits	2	0	0	0
Receivables - Rates	0	279,317	2,195,438	2,527,459
Receivables - Other	3	226,508	327,699	373,488
Other Financial Assets	3	0	0	0
Other Assets Other Than Inventories	4	687,687	837,395	362,140
Inventories	4	8,674	(10,218)	41,064
		8,242,526	9,114,916	8,514,604
Less: Current Liabilities				
Payables	5	(1,361,321)	(284,861)	(576,600)
Contract Liabilities	11	(238,647)	(609,700)	(247,647)
Bonds & Deposits	14	(51,392)	(95,432)	(69,202)
Loan Liability	9	(67,898)	(33,274)	(60,432)
Lease Liability	9	(11,047)	(14,330)	(11,047)
Provisions	11	(176,085)	(184,697)	(176,085)
		(1,906,389)	(1,222,294)	(1,141,012)
Less: Cash Reserves	10	(4,111,639)	(4,093,439)	(4,111,639)
Add Back: Component of Leave Liability not Required to be funded		177,149	171,302	177,149
Add Back: Loan Liability		67,898	33,274	60,432
Add Back: Lease Liability		11,047	14,330	11,047
Less: Loan Receivable - clubs/institutions		0	0	0
Net Current Funding Position		2,480,591	4,018,089	3,510,580

SIGNIFICANT ACCOUNTING POLICIES

Please see Note 1(a) for information on significant accounting policies relating to Net Current Assets.

KEY INFORMATION

The amount of the adjusted net current assets at the end of the period represents the actual surplus (or deficit if the figure is a negative) as presented on the Rate Setting Statement.

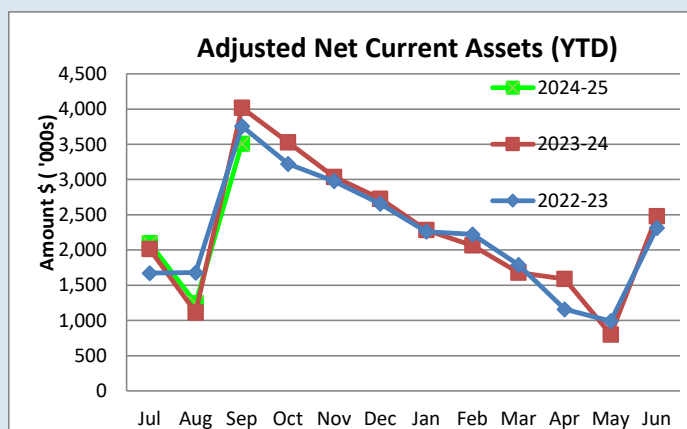

This Year YTD

Surplus(Deficit)

\$3.51 M

Last Year YTD

Surplus(Deficit)

\$4.02 M

SHIRE OF QUAIRADING

NOTES TO THE STATEMENT OF FINANCIAL ACTIVITY
FOR THE PERIOD ENDED 30 SEPTEMBER 2024

OPERATING ACTIVITIES
NOTE 2
CASH AND FINANCIAL ASSETS

	Unrestricted	Restricted Reserves	Restricted Muni	Total Amount	Institution	Interest Rate	Maturity Date
	\$	\$	\$	\$			
Cash on Hand							
Cash on Hand - Admin	1,300			1,300	Cash on Hand	Nil	On Hand
Petty Cash - Container Deposit Scheme	499			499	Cash on Hand	Nil	On Hand
At Call Deposits							
Municipal Cash at Bank	437,149			437,149	Westpac		Ongoing
Municipal Investment Cash at Bank	0			0	Westpac	Nil	Ongoing
Medical Practice Cash at Bank	(32)			(32)	Westpac		Ongoing
Reserve Cash at Bank		386,787		386,787	Westpac	1.55%	Ongoing
Trust Cash at Bank			0	0	Westpac		Ongoing
Term Deposits							
Municipal - Term Deposit Investment 1	328,069			328,069	Westpac	3.55%	12/11/2024
Municipal - Term Deposit Investment 2	331,828			331,828	Westpac	3.55%	12/11/2024
Reserve - Term Deposit Investment 1		1,013,834		1,013,834	Westpac	5.16%	2/10/2024
Reserve - Term Deposit Investment 2		659,504		659,504	Westpac	5.16%	2/10/2024
Reserve - Term Deposit Investment 3		1,093,417		1,093,417	Westpac	5.16%	2/10/2024
Reserve - Term Deposit Investment 4		958,097		958,097	Westpac	5.16%	2/10/2024
		0		0			
		0		0			
Investments							
Total	1,098,814	4,111,639	0	5,210,453			

SIGNIFICANT ACCOUNTING POLICIES

Cash and cash equivalents include cash on hand, cash at bank, deposits available on demand with banks and other short term highly liquid investments that are readily convertible to known amounts of cash and which are subject to an insignificant risk of changes in value and bank overdrafts. Bank overdrafts are reported as short term borrowings in current liabilities in the statement of financial position.

KEY INFORMATION

Cash and cash equivalents include cash on hand, cash at bank, deposits available on demand with banks and other short term highly liquid investments that are readily convertible to known amounts of cash and which are subject to an insignificant risk of changes in value and bank overdrafts. Bank overdrafts are reported as short term borrowings in current liabilities in the statement of financial position.

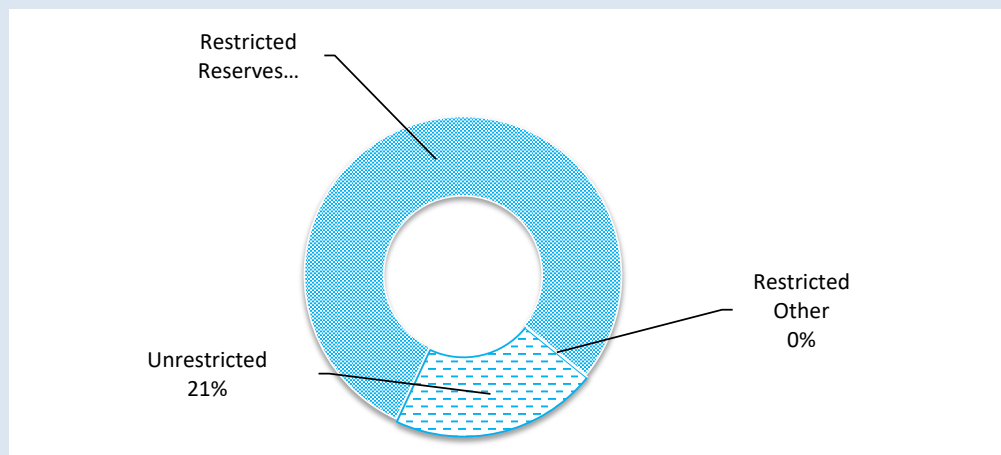

Total Cash	Restricted
\$5.21 M	\$4.11 M

SHIRE OF QUAIRADING

NOTES TO THE STATEMENT OF FINANCIAL ACTIVITY
FOR THE PERIOD ENDED 30 SEPTEMBER 2024

OPERATING ACTIVITIES
NOTE 3
RECEIVABLES

Receivables - Rates & Rubbish	30 June 2024	30 Sep 24
	\$	\$
Opening Arrears Previous Years	282,891	314,891
Levied this year	2,762,616	2,926,701
Less Collections to date	(2,730,617)	(678,559)
Equals Current Outstanding	314,891	2,563,032
	314,891	2,563,032
% Collected	89.66%	20.93%

Receivables - General	Current	30 Days	60 Days	90+ Days	Total
	\$	\$	\$	\$	\$
Receivables - General	45,539	4,154	45,915	105,560	201,168
Percentage	23%	2%	23%	52%	
Balance per Trial Balance					
Sundry Debtors					199,768
Receivables - Other					173,720
Total Receivables General Outstanding					373,488

Amounts shown above include GST (where applicable)

KEY INFORMATION

Trade and other receivables include amounts due from ratepayers for unpaid rates and service charges and other amounts due from third parties for goods sold and services performed in the ordinary course of business.

SIGNIFICANT ACCOUNTING POLICIES

Trade and other receivables include amounts due from ratepayers for unpaid rates and service charges and other amounts due from third parties for goods sold and services performed in the ordinary course of business. Receivables expected to be collected within 12 months of the end of the reporting period are classified as current assets. All other receivables are classified as non-current assets. Collectability of trade and other receivables is reviewed on an ongoing basis. Debts that are known to be uncollectible are written off when identified. An allowance for doubtful debts is raised when there is objective evidence that they will not be collectible.

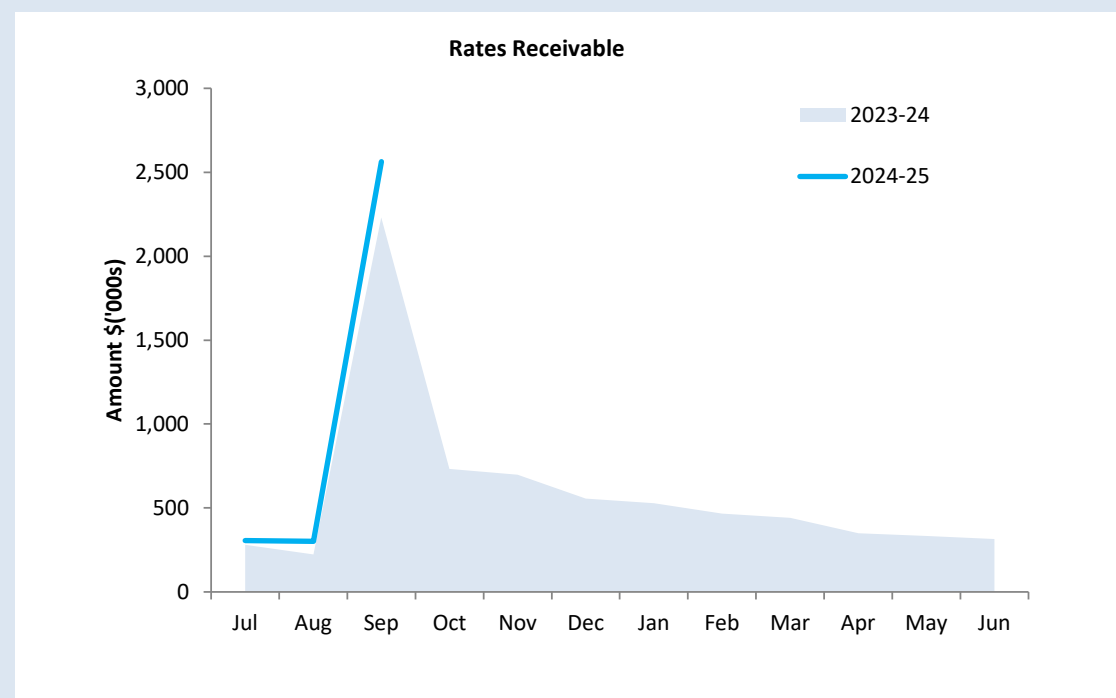

Collected	Rates Due
21%	\$2,563,032

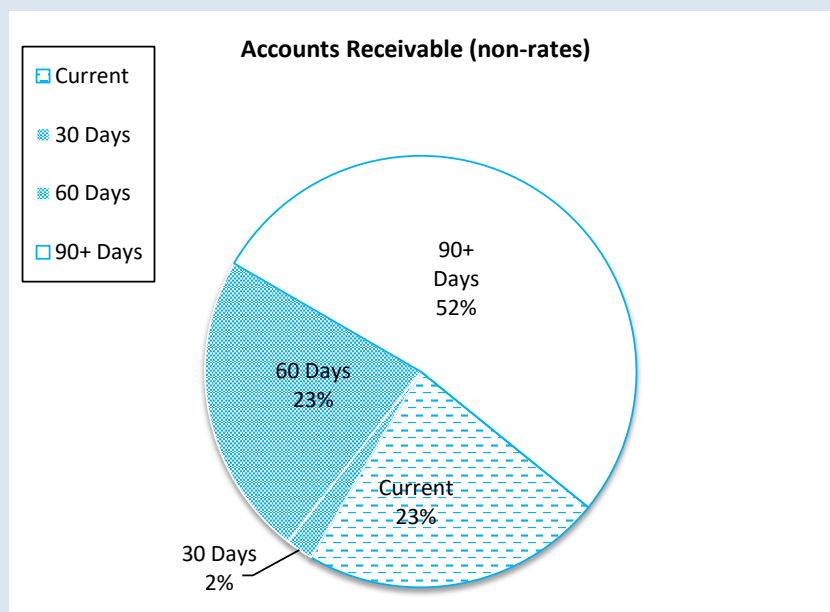

Debtors Due
\$373,488
Over 30 Days
77%
Over 90 Days
52%

SHIRE OF QUAIRADING
NOTES TO THE STATEMENT OF FINANCIAL ACTIVITY
FOR THE PERIOD ENDED 30 SEPTEMBER 2024

OPERATING ACTIVITIES
NOTE 4
OTHER CURRENT ASSETS

	Opening Balance 1 Jul 2024	Asset Increase	Asset Reduction	Closing Balance 30 Sep 2024
	\$	\$	\$	\$
Other Current Assets				
Other Financial Assets at Amortised Cost				
Financial assets at amortised cost - self supporting loans	0	0	0	0
Inventory				
Fuel, Visitor and Rec Centres stock on hand	8,674	32,390	0	41,064
Accrued income and prepayments				
Accrued income and prepayments	11,118	0	(10,869)	249
Contract assets				
Contract assets	676,569	0	(314,678)	361,891
Total Other Current assets				583,204
Amounts shown above include GST (where applicable)				

KEY INFORMATION

Other financial assets at amortised cost

The Shire classifies financial assets at amortised cost if both of the following criteria are met:

- the asset is held within a business model whose objective is to collect the contractual cashflows, and
- the contractual terms give rise to cash flows that are solely payments of principal and interest.

Inventory

Inventories are measured at the lower of cost and net realisable value.

Net realisable value is the estimated selling price in the ordinary course of business less the estimated costs of completion and the estimated costs necessary to make the sale.

Land held for resale

Land held for development and resale is valued at the lower of cost and net realisable value. Cost includes the cost of acquisition, development, borrowing costs and holding costs until completion of development.

Borrowing costs and holding charges incurred after development is completed are expensed.

Gains and losses are recognised in profit or loss at the time of signing an unconditional contract of sale if significant risks and rewards, and effective control over the land, are passed onto the buyer at this point.

Land held for resale is classified as current except where it is held as non-current based on the Council's intentions to release for sale.

CONTRACT ASSETS

A contract asset is the right to consideration in exchange for goods or services the entity has transferred to a customer when that right is conditioned on something other than the passage of time.

SHIRE OF QUAIRADING
NOTES TO THE STATEMENT OF FINANCIAL ACTIVITY
FOR THE PERIOD ENDED 30 SEPTEMBER 2024

OPERATING ACTIVITIES
NOTE 5
Payables

Payables - General	Current	30 Days	60 Days	90+ Days	Total
	\$	\$	\$	\$	\$
Payables (Sundry Creditors) - General	122,624	55,633	0	3,645	181,901
Percentage	67.4%	30.6%	0%	2%	
Balance per Trial Balance					
Sundry creditors - General					328,584
Other creditors					55,876
Accruals/Income in Advance					390
ATO liabilities					168,743
Other accruals/payables					23,006
Total Payables General Outstanding					576,600

Amounts shown above include GST (where applicable)

KEY INFORMATION

Trade and other payables represent liabilities for goods and services provided to the Shire that are unpaid and arise when the Shire becomes obliged to make future payments in respect of the purchase of these goods and services. The amounts are unsecured, are recognised as a current liability and are normally paid within 30 days of recognition.

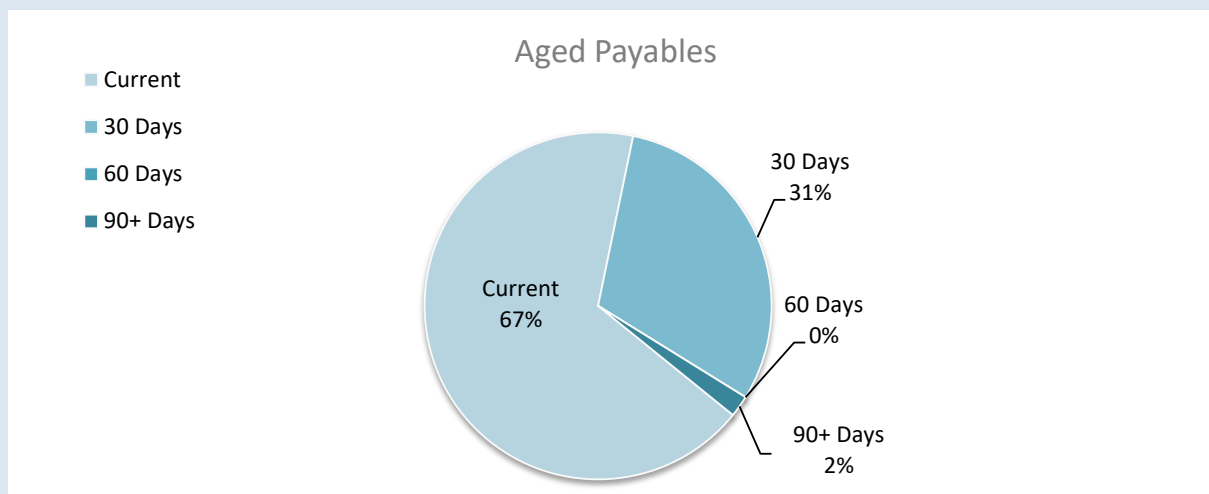

Creditors Due
\$576,600
Over 30 Days
33%
Over 90 Days
2%

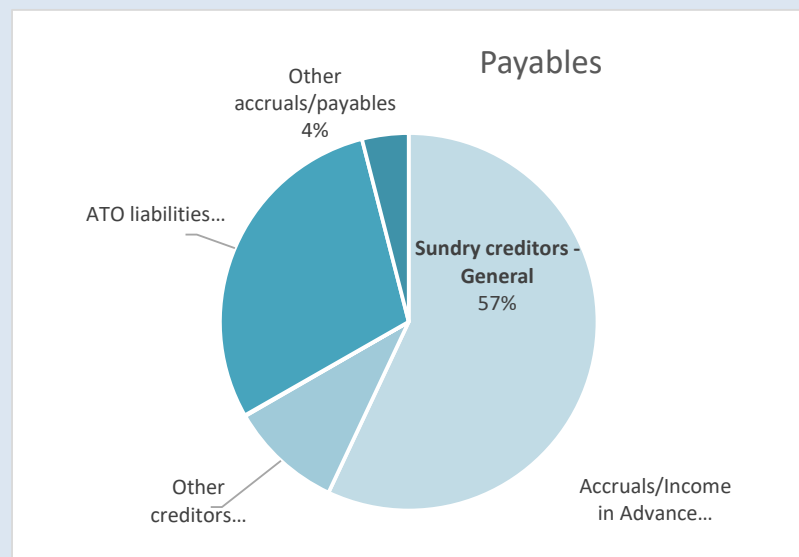
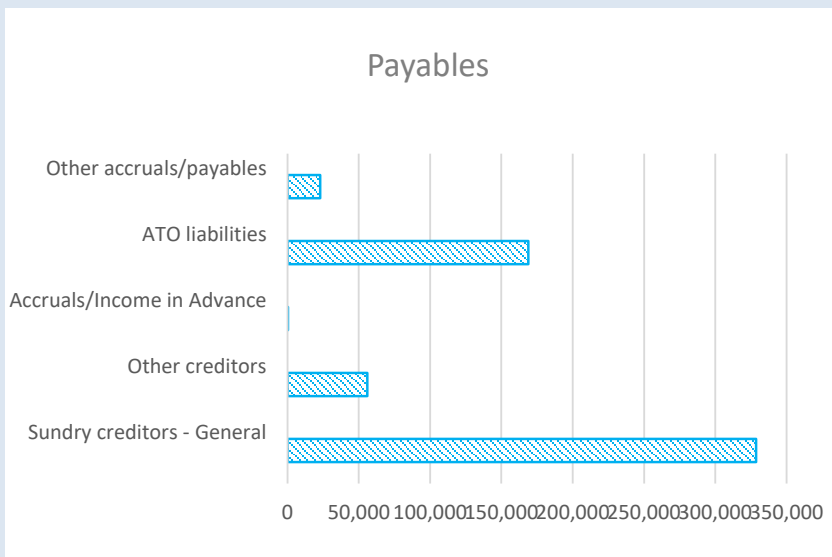

SHIRE OF QUAIRADING
 NOTES TO THE STATEMENT OF FINANCIAL ACTIVITY
 FOR THE PERIOD ENDED 30 SEPTEMBER 2024

OPERATING ACTIVITIES
 NOTE 6
 RATE REVENUE

RATE TYPE	Budget							YTD Actual			
	Rate in	Number of Properties	Rateable Value	Rate Revenue	Interim Rate	Back Rate	Total Revenue	Rate Revenue	Interim Rates	Back Rates	Total Revenue
	\$			\$	\$	\$	\$	\$	\$	\$	\$
General Rate											
Gross rental valuations											
GRV - Residential	0.138187	378	3,146,437	434,315	0	0	434,315	434,138	0		434,138
GRV - Industrial	0.138187	29	274,950	37,995	0	0	37,995	37,994	0	0	37,994
GRV - Commercial	0.138187	11	209,776	28,988	0	0	28,988	28,988	0	0	28,988
Unimproved valuations											
UV - Rural	0.006820	412	319,919,412	2,181,848	0	0	2,181,848	2,181,711	0	0	2,181,711
Non Rateable		231	60,902,337	0	0	0	0	0	0	0	0
Sub-Totals		1,061	384,452,912	2,683,146	0	0	2,683,146	2,682,831	0	0	2,682,831
Minimum Payment											
Minimum											
\$											
Gross rental valuations											
GRV - Residential	756	61	0	46,116	0	0	46,116	46,116	0	0	46,116
GRV - Industrial	756	8	0	6,048	0	0	6,048	6,048	0	0	6,048
GRV - Commercial	756	1	0	756	0	0	756	756	0	0	756
Unimproved valuations											
UV - Rural	756	60	0	45,360	0	0	45,360	45,360	0	0	45,360
Sub-Totals		130	0	98,280	0	0	98,280	98,280	0	0	98,280
		1,191	384,452,912	2,781,426	0	0	2,781,426	2,781,111	0	0	2,781,111
Amount from General Rates											
Ex-Gratia Rates	Tonnage	1	0	18,310	0	0	18,310	0	0	0	0
Write off							0				0
Specified Area Rates							0				0
Total Rates							2,799,736				2,781,111

SHIRE OF QUAIRADING
 NOTES TO THE STATEMENT OF FINANCIAL ACTIVITY
 FOR THE PERIOD ENDED 30 SEPTEMBER 2024

OPERATING ACTIVITIES
 NOTE 7
 DISPOSAL OF ASSETS

Asset Number	Asset Description	Amended Budget				YTD Actual			
		Net Book Value	Proceeds	Profit	(Loss)	Net Book Value	Proceeds	Profit	(Loss)
		\$	\$	\$	\$	\$	\$	\$	\$
Land Held for Resale									
1200	Lhfr - Lot 301 (8) Edwards Way	38,760	10,000		(28,760)	0	0		
1201	Lhfr - Lot 302 (6) Edwards Way	41,040	10,000		(31,040)	0	0		
1202	Lhfr - Lot 303 (4) Edwards Way	39,900	10,000		(29,900)	0	0		
1203	Lhfr - Lot 304 (2) Edwards Way	39,900	10,000		(29,900)	0	0		
1204	Lhfr - Lot 305 (15) Reid Street	41,040	10,000		(31,040)	0	0		
1205	Lhfr - Lot 328 (11) Edwards Way	39,900	10,000		(29,900)	0	0		
1206	Lhfr - Lot 321 (9) Edwards Way	39,900	10,000		(29,900)	0	0		
1207	Lhfr - Lot 323 (5) Edwards Way	39,900	10,000		(29,900)	0	0		
1208	Lhfr - Lot 324 (3) Edwards Way	39,900	10,000		(29,900)	0	0		
1209	Lhfr - Lot 325 (1) Edwards Way	41,040	10,000		(31,040)	0	0		
1210	Lhfr - Lot 326 (19) Edwards Way	45,600	10,000		(35,600)	0	0		
1211	Lhfr - Lot 327 (21) Reid Street	42,180	10,000		(32,180)	0	0		
1213	Lhfr - Lot 94 Hinkley Way, Quairading.	57,000	35,000		(22,000)	0	0		
1214	Lhfr - Lot 95 Hinkley Way, Quairading.	34,200	35,000	800		0	0		
Plant and Equipment									
1Q3919	Ammann Ars130 Single Drum Roller	84,686	80,000		(4,686)	0	0		
1Q240	2015 Caterpillar 12 M Grader	149,345	150,000	655		0	0		
1Q368	2016 Caperpillar Loader 938K2	153,111	180,000	26,889.35		0	0		
Q5122	2012 Ud Nissan Truck	69,200	110,000	40,800		0	81,818	0	
2Q661	Mitsubishi Triton Glx Cc Man	11,720	24,000	12,280		0	0		
6Q190	Isuzu Dmax 4X4 Ute	24,907	25,000	93		0	0		
1Q960	2019 Multipac 524H Multi Tyred Roller	78,337	80,000	1,663		0	0		
1Q754	2017 John Deere 5065E Tractor	23,265	10,000		(13,265)	0	0		
Q5191	Model S30 Rider Sweeper	8,840	25,000	16,160		0	0		
Aged Other									
1Q5335	Toyota Camry 2.5L Ascent	24,390	22,000		(2,390)	0	0		
Administration									
8Q0	Mazda Cx9 Touring Awd	24,633	24,000		(633)	0	21,818	0	
		1,232,693	920,000	99,341	(412,034)	0	103,636	0	0

KEY INFORMATION

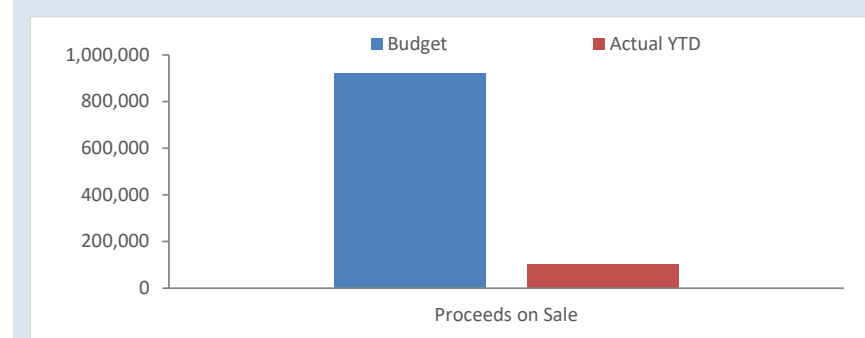

Proceeds on Sale		
Budget	YTD Actual	%
\$920,000	\$103,636	11%

SHIRE OF QUAIRADING

NOTES TO THE STATEMENT OF FINANCIAL ACTIVITY

FOR THE PERIOD ENDED 30 SEPTEMBER 2024

INVESTING ACTIVITIES
NOTE 8
CAPITAL ACQUISITIONS

Capital Acquisitions	Adopted		Amended		YTD Budget Variance
	Annual Budget	YTD Budget	Annual Budget	YTD Actual Total	
	\$	\$	\$	\$	\$
Land Held for Resale	50,000	12,504	50,000	0	(12,504)
Land and Buildings	751,494	201,396	751,494	76,678	(124,718)
Plant and Equipment	1,373,057	464,654	1,373,057	484,500	19,846
Furniture and Equipment	15,000	3,750	15,000	0	(3,750)
Infrastructure Assets - Roads	1,859,924	431,913	1,859,924	60,900	(371,013)
Infrastructure Assets - Footpaths	5,500	1,374	5,500	5,500	4,126
Infrastructure Assets - Other	553,081	129,504	553,081	47,857	(81,647)
Infrastructure Assets - Bridges	20,000	4,998	20,000	20,000	15,002
Capital Expenditure Totals	4,628,055	1,250,093	4,628,055	695,435	(554,658)
Capital acquisitions funded by:					
	\$	\$	\$	\$	\$
Capital Grants and Contributions	2,066,381	299,708	2,066,381	(28,607)	(328,315)
Borrowings	0	0	0	0	0
Other (Disposals & C/Fwd)	920,000	242,499	920,000	103,636	(138,863)
Council contribution - Cash Backed Reserves					
Various Reserves	530,000	0	530,000	0	0
Council contribution - operations	1,111,675	707,886	1,111,675	620,406	(87,480)
Capital Funding Total	4,628,055	1,250,093	4,628,055	695,435	(554,658)

SIGNIFICANT ACCOUNTING POLICIES

All assets are initially recognised at cost. Cost is determined as the fair value of the assets given as consideration plus costs incidental to the acquisition. For assets acquired at no cost or for nominal consideration, cost is determined as fair value at the date of acquisition. The cost of non-current assets constructed by the local government includes the cost of all materials used in the construction, direct labour on the project and an appropriate proportion of variable and fixed overhead. Certain asset classes may be revalued on a regular basis such that the carrying values are not materially different from fair value. Assets carried at fair value are to be revalued with sufficient regularity to ensure the carrying amount does not differ materially from that determined using fair value at reporting date.

KEY INFORMATION

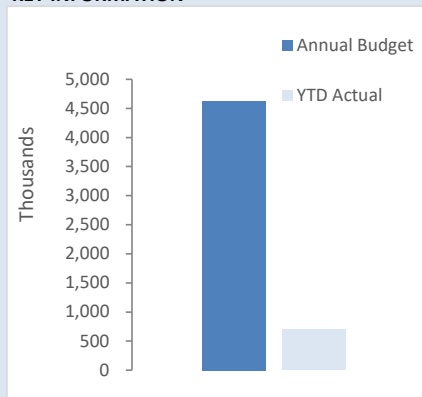

Acquisitions	Annual Budget	YTD Actual	% Spent
	\$4.63 M	\$0.7 M	15%
Capital Grant	Annual Budget	YTD Actual	% Received
	\$2.07 M	-\$0.3 M	-1%

**SHIRE OF QUAIRADING
NOTES TO THE STATEMENT OF FINANCIAL ACTIVITY
FOR THE PERIOD ENDED 30 SEPTEMBER 2024**

**INVESTING ACTIVITIES
NOTE 8
CAPITAL ACQUISITIONS**

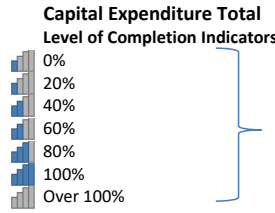

Percentage YTD Actual to Annual Budget Expenditure over budget highlighted in red.

% of Completion	Level of completion indicator, please see table at the top of this note for further detail.	Balance			Adopted	Amended		Total YTD	Variance (Under)/Over
		Account Number	Sheet Category	Job Number	Annual Budget	Annual Budget	YTD Budget		
	Assets				\$	\$	\$	\$	\$
	Land Held for Resale								
	Community Amenities								
0.00	Stage 2 Light Industrial Subdivision	4100607	507	TP0000	(50,000)	(50,000)	(12,501)	0	12,501
	Total - Community Amenities				(50,000)	(50,000)	(12,501)	0	12,501
0.00	Total - Land Held for Resale				(50,000)	(50,000)	(12,501)	0	12,501
	Buildings								
	Health								
0.22	Medical Centre - Building (Capital)	4070712	512	BC7702	(12,500)	(12,500)	0	(2,760)	(2,760)
	Total - Health				(12,500)	(12,500)	0	(2,760)	(2,760)
	Education & Welfare								
1.16	Daycare Centre - Building (Capital)	4080612	512	BC8301	(20,000)	(20,000)	(9,247)	(23,113)	(13,866)
1.00	Arthur Kelly Village - Common Area - Building (Capital)	4080612	512	BC8600	0	0	0	(2,320)	(2,320)
0.73	Frail Aged Lodge (Parker House) - Building (Capital)	4080612	512	BC8610	(30,594)	(30,594)	(7,644)	(22,407)	(14,763)
0.00	Youth Centre - Building (Capital)	4080712	512	BC8701	(10,000)	(10,000)	(2,496)	0	2,496
	Total - Education & Welfare				(60,594)	(60,594)	(19,387)	(47,841)	(28,454)
	Housing								
0.00	14 Reid Street - Building (Capital)	4090114	514	BC9101	(5,000)	(5,000)	(1,248)	0	1,248
0.05	1/19 Gillett Street - Single Persons Unit - Building (Capital)	4090114	514	BC9102	(3,750)	(3,750)	(933)	(198)	735
0.00	31 Dall Street - Building (Capital)	4090114	514	BC9103	(11,000)	(11,000)	(2,748)	0	2,748
0.00	8 Dall Street - Building (Capital)	4090114	514	BC9104	(33,490)	(33,490)	(8,370)	0	8,370
0.00	4/19 Gillett Street - Single Persons Unit - Building (Capital)	4090114	514	BC9112	(3,750)	(3,750)	(933)	0	933
0.05	2/19 Gillett Street - Single Persons Unit - Building (Capital)	4090214	514	BC9202	(3,750)	(3,750)	(933)	(198)	735
0.03	3/19 Gillett Street - Single Persons Unit - Building (Capital)	4090214	514	BC9203	(6,550)	(6,550)	(1,635)	(198)	1,437
1.00	7 Edwards Way - Police House - Building (Capital)	4090214	514	BC9208	0	0	0	(21,630)	(21,630)
	Total - Housing				(67,290)	(67,290)	(16,800)	(22,224)	(5,424)
	Community Amenities								
0.00	Recycling Centre - Building (Capital)	4100112	512	BC10102	(88,376)	(88,376)	(22,092)	0	22,092
	Total - Community Amenities				(88,376)	(88,376)	(22,092)	0	22,092
	Recreation And Culture								
0.00	Swimming Pool - Building (Capital)	4110212	512	BC11201	(28,000)	(28,000)	(6,999)	0	6,999
0.30	Swimming Pool Kiosk - Building (Capital)	4110212	512	BC11202	(5,000)	(5,000)	(1,248)	(1,500)	(252)
0.00	Swimming Pool Plant Room - Building (Capital)	4110712	512	BC11205	(50,000)	(50,000)	(24,995)	0	24,995
0.00	Golf Club - Building (Capital)	4110312	512	BC11305	(6,000)	(6,000)	(1,497)	0	1,497
	Total - Recreation And Culture				(89,000)	(89,000)	(34,739)	(1,500)	33,239
	Transport								
0.00	Depot Workshop - Building (Capital)	4120112	512	BC12201	(8,617)	(8,617)	(2,148)	0	2,148
	Total - Transport				(8,617)	(8,617)	(2,148)	0	2,148
	Economic Services								
0.00	Cabin 4 - 1 Bedroom Unit (Capital)	4130212	512	BC13248	(205,000)	(205,000)	(51,228)	0	51,228
0.00	Cabin 5 - 1 Bedroom Unit (Capital)	4130212	512	BC13249	(205,000)	(205,000)	(51,228)	0	51,228
0.16	Veterinary Clinic - Building (Capital)	4130812	512	BC13810	(15,117)	(15,117)	(3,774)	(2,354)	1,420
	Total - Economic Services				(425,117)	(425,117)	(106,230)	(2,354)	103,876
0.10	Total - Buildings				(751,494)	(751,494)	(201,396)	(76,678)	124,718
	Plant & Equipment								
	Transport								
0.72	Works Supervisors Vehicle	4120330	530	PE12301	(72,000)	(72,000)	0	(52,101)	(52,101)
0.83	Tractor FEL (90HP)	4120330	530	PE12304	(90,000)	(90,000)	(22,500)	(75,000)	(52,500)
0.00	Smooth Drum Vibe Roller 12T	4120330	530	PE12311	(300,000)	(300,000)	0	0	0
0.80	Mazda BT50 Ute	4120330	530	PE12313	(65,000)	(65,000)	0	(51,724)	(51,724)
0.00	Grader	4120330	530	PE12314	(400,000)	(400,000)	(400,000)	0	400,000
0.91	6 Wheel Tip Truck	4120330	530	PE12317	(292,702)	(292,702)	0	(266,899)	(266,899)
0.00	Tenant Sweeper	4120330	530	PE12319	(75,000)	(75,000)	0	0	0
	Total - Transport				(1,294,702)	(1,294,702)	(422,500)	(445,724)	(23,224)
	Economic Services								
0.00	Toyota Camry - Community Car	4120330	530	PE12320	(36,200)	(36,200)	0	0	0
	Total - Economic Services				(36,200)	(36,200)	0	0	0
	Other Property & Services								
0.00	Purchase of New CEO Vehicle	4140230	530	PE14201	(42,154)	(42,154)	(42,154)	0	42,154

**SHIRE OF QUAIRADING
NOTES TO THE STATEMENT OF FINANCIAL ACTIVITY
FOR THE PERIOD ENDED 30 SEPTEMBER 2024**

**INVESTING ACTIVITIES
NOTE 8
CAPITAL ACQUISITIONS**

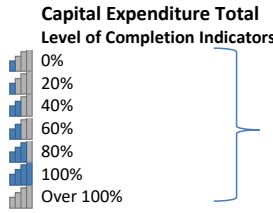

Percentage YTD Actual to Annual Budget
Expenditure over budget highlighted in red.

% of Completion	Level of completion indicator, please see table at the top of this note for further detail.	Balance			Adopted	Amended		Total YTD	Variance (Under)/Over
		Account Number	Sheet Category	Job Number	Annual Budget	Annual Budget	YTD Budget		
	Assets				\$	\$	\$	\$	\$
1.00	Purchase of New CEO Vehicle - Natalie Ness	4140230	530	PE14203	0	0	0	(38,776)	(38,776)
	Total - Other Property & Services				(42,154)	(42,154)	(42,154)	(38,776)	3,378
0.35	Total - Plant & Equipment				(1,373,057)	(1,373,057)	(464,654)	(484,500)	(19,846)
	Furniture & Equipment								
	Other Property & Services								
0.00	Chambers Furniture Upgrade	4140220	520	FE14202	(15,000)	(15,000)	(3,750)	0	3,750
	Total - Other Property & Services				(15,000)	(15,000)	(3,750)	0	3,750
0.00	Total - Furniture & Equipment				(15,000)	(15,000)	(3,750)	0	3,750
	Infrastructure - Roads								
	Transport								
0.00	Dangin Terrace (R2R)	4120144	540	R2R169	(22,000)	(22,000)	(5,499)	0	5,499
0.00	Walker Street (R2R)	4120144	540	R2R138	(60,000)	(60,000)	(15,000)	0	15,000
0.00	Cubbine Road, Cubbine (R2R)	4120145	540	R2R005	(83,562)	(83,562)	(20,889)	0	20,889
0.00	Kellerberrin - Yoting Road (R2R)	4120145	540	R2R164	(90,000)	(90,000)	(22,500)	0	22,500
0.00	Quairading - Corrigin Road (R2R)	4120145	540	R2R166	(140,000)	(140,000)	(34,998)	0	34,998
0.44	Hayes Road (R2R)	4120145	540	R2R015	(70,000)	(70,000)	(17,499)	(30,960)	(13,461)
0.07	Andrews Road (R2R)	4120145	540	R2R105	(82,041)	(82,041)	0	(6,015)	(6,015)
1.00	Old Beverley West Road (R2R)	4120146	540	R2R007	0	0	0	(14,836)	(14,836)
0.00	RRG - Quairading - Corrigin Road (Capital) 23/24 SLK 20.47 - 23.02	4120149	540	RRG166B	(105,245)	(105,245)	(26,298)	0	26,298
0.00	Bulyee - Quairading Road (RRG)	4120148	540	RRG002	(554,765)	(554,765)	(138,687)	(1,143)	137,544
0.01	Old Beverley East Road (RRG)	4120149	540	RRG006	(244,673)	(244,673)	(61,152)	(1,911)	59,241
0.00	Old Beverley East Road (LRCI Funded)	4120162	540	LRC006	(244,649)	(244,649)	(61,155)	0	61,155
0.10	Dangin - Mears Road - WSNF Development Expenditure	4120162	540	WSF010D	(62,990)	(62,990)	(15,741)	(6,036)	9,705
	Total - Transport				(1,759,924)	(1,759,924)	(419,418)	(60,900)	358,518
0.03	Total - Infrastructure - Roads				(1,759,924)	(1,759,924)	(419,418)	(60,900)	358,518
	Infrastructure - Drainage								
	Transport								
0.00	Punch Road - Drainage Capital	4120166	540	DC143	(20,000)	(20,000)	(2,499)	0	2,499
0.00	Minchin Road - Drainage Capital	4120166	540	DC063	(20,000)	(20,000)	(2,499)	0	2,499
0.00	Squiers Road - Drainage Capital	4120166	540	DC176	(20,000)	(20,000)	(2,499)	0	2,499
0.00	Toapin Road - Drainage Capital	4120166	540	DC055	(20,000)	(20,000)	(2,499)	0	2,499
0.00	Quairading - Corrigin Road - Drainage Capital	4120166	540	DC166	(20,000)	(20,000)	(2,499)	0	2,499
	Total - Transport				(100,000)	(100,000)	(12,495)	0	12,495
0.00	Total - Infrastructure - Drainage				(100,000)	(100,000)	(12,495)	0	12,495
	Infrastructure - Footpaths								
	Transport								
0.00	Harris Street - Footpath Capital	4120170	560	FC130	(5,500)	(5,500)	(1,374)	0	1,374
	Total - Transport				(5,500)	(5,500)	(1,374)	0	1,374
0.00	Total - Infrastructure - Footpaths				(5,500)	(5,500)	(1,374)	0	1,374
	Infrastructure - Bridges								
	Transport								
1.00	Badjaling North Road - Bridge (Capital)	4120167	555	BR4145	(20,000)	(20,000)	(4,998)	(20,000)	(15,002)
	Total - Transport				(20,000)	(20,000)	(4,998)	(20,000)	(15,002)
1.00	Total - Infrastructure - Bridges				(20,000)	(20,000)	(4,998)	(20,000)	(15,002)
	Infrastructure - Other								
	Law, Order & Public Safety								
0.00	Solar Electronic Fire Danger Signs (Capital) - DRF Funded	4050790	590	EM5702	(30,000)	(30,000)	(3,750)	0	3,750
	Total - Law, Order & Public Safety				(30,000)	(30,000)	(3,750)	0	3,750
	Community Amenities								
0.00	Cemetery Upgrade (Capital)	4100790	590	OC10703	(16,792)	(16,792)	(4,194)	0	4,194
	Total - Community Amenities				(16,792)	(16,792)	(4,194)	0	4,194
	Recreation And Culture								
0.00	Cricket Nets (Capital)	4110390	590	OC11344	(44,792)	(44,792)	(11,193)	0	11,193
0.00	Skate Park (Capital)	4110390	590	OC11345	(25,000)	(25,000)	(6,249)	0	6,249

**SHIRE OF QUAIRADING
NOTES TO THE STATEMENT OF FINANCIAL ACTIVITY
FOR THE PERIOD ENDED 30 SEPTEMBER 2024**

**INVESTING ACTIVITIES
NOTE 8
CAPITAL ACQUISITIONS**

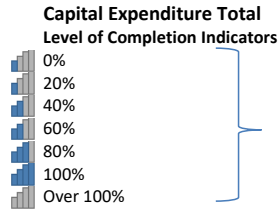

Percentage YTD Actual to Annual Budget
Expenditure over budget highlighted in red.

% of
Completion

Level of completion indicator, please see table at the top of this note for further detail.

	Account Number	Balance Sheet Category	Job Number	Adopted		Amended		Total YTD	Variance (Under)/Over
				Annual Budget	Annual Budget	YTD Budget			
Assets									
0.00	Bore Field	4110390	590	PC11315	(38,661)	(38,661)	(9,660)	0	9,660
0.04	Greater Sports Ground (GSC) - Netball/Basketball Courts (LRCI Funde	4110390	590	LRC11335	(377,836)	(377,836)	(94,458)	(15,555)	78,903
Total - Recreation And Culture					(486,289)	(486,289)	(121,560)	(15,555)	106,005
Economic Services									
1.53	Standpipe Controller 1	4130890	590	OC13801	(20,000)	(20,000)	0	(30,674)	(30,674)
Total - Economic Services					(20,000)	(20,000)	0	(30,674)	(30,674)
0.08	Total - Infrastructure - Other				(553,081)	(553,081)	(129,504)	(46,229)	83,275
0.15	Grand Total				(4,628,055)	(4,628,055)	(1,250,090)	(688,307)	561,783

Summary by Balance Sheet Category

Land Held For Resale (Current)	340	0	0	0	0	0
Land Held For Resale (Non Current)	507	(50,000)	(50,000)	(12,501)	0	12,501
Land - Freehold	508	0	0	0	0	0
Buildings - Specialised	512	(684,204)	(684,204)	(184,596)	(54,455)	130,141
Buildings - Non Specialised	514	(67,290)	(67,290)	(16,800)	(22,224)	(5,424)
Furniture & Equipment	520	(15,000)	(15,000)	(3,750)	0	3,750
Plant & Equipment	530	(1,373,057)	(1,373,057)	(464,654)	(484,500)	(19,846)
Infrastructure - Roads	540	(1,859,924)	(1,859,924)	(431,913)	(60,900)	371,013
Infrastructure - Bridges	555	(20,000)	(20,000)	(4,998)	(20,000)	(15,002)
Infrastructure - Footpaths & Cycleways	560	(5,500)	(5,500)	(1,374)	0	1,374
Infrastructure - Other	590	(553,081)	(553,081)	(129,504)	(46,229)	83,275
		0	0	0	0	0
		0	0	0	0	0
		0	0	0	0	0
		(4,628,055)	(4,628,055)	(1,250,090)	(688,307)	561,783

SHIRE OF QUAIRADING
 NOTES TO THE STATEMENT OF FINANCIAL ACTIVITY
 FOR THE PERIOD ENDED 30 SEPTEMBER 2024

FINANCING ACTIVITIES
 NOTE 9
 LOAN DEBENTURE BORROWINGS AND FINANCING

(a) Information on Loan Debenture Borrowings

Particulars/Purpose	01 Jul 2024	New Loans			Principal Repayments			Principal Outstanding			Interest & Guarantee Fee Repayments		
		Actual	Amended Budget	Adopted Budget	Actual	Amended Budget	Adopted Budget	Actual	Amended Budget	Adopted Budget	Actual	Amended Budget	Adopted Budget
		\$	\$	\$	\$	\$	\$	\$	\$	\$	\$	\$	\$
Transport													
Loan 118 - Depot Building	192,389	0	0	0	0	52,911	52,911	192,389	139,477	139,477	-747	5,450	5,450
Loan 119 - Park Cottages	85,229	0	0	0	7,466	14,987	14,987	77,764	70,243	70,243	230	1,206	1,206
	277,618	0	0	0	7,466	67,898	67,898	270,152	209,720	209,720	-517	6,656	6,656
Total	277,618	0	0	0	7,466	67,898	67,898	270,152	209,720	209,720	-517.31	6,656	6,656
Current loan borrowings	67,898							60,432					
Non-current loan borrowings	209,720							209,720					
	277,618							270,152					

All debenture repayments were financed by general purpose revenue.

(b) Information on Financing

Particulars/Purpose	01 Jul 2024	New Financing			Lease Financing Principal Repayments			Lease Financing Principal Outstanding			Lease Financing Interest Repayments		
		Actual	Amended Budget	Adopted Budget	Actual	Amended Budget	Adopted Budget	Actual	Amended Budget	Adopted Budget	Actual	Amended Budget	Adopted Budget
		\$	\$	\$	\$	\$	\$	\$	\$	\$	\$	\$	\$
Law, Order & Public Safety													
Lease 2 - CESM Vehicle	17,555	0	0	0	0	17,555	17,555	17,555	(0)	-0	0	0	0
Economic Services													
Matrix Cardio Equipment	31,692	0	0	0	0	12,370	12,370	31,692	19,322	19,322	0	1,324	1,324
Other Property & Services													
Lease 3 - Canon Photocopier	0	0	0	0	0	0	0	0	0	0	0	0	0
	49,247	0	0	0	0	29,925	29,925	49,247	19,322	19,322	0	1,324	1,324
Total	49,247	0	0	0	0	29,925	29,925	49,247	19,322	19,322	0	1,324	1,324
Current financing borrowings	11,047							11,047					
Non-current financing borrowings	20,646							20,646					
	31,693							31,693					

SHIRE OF QUAIRADING
NOTES TO THE STATEMENT OF FINANCIAL ACTIVITY
FOR THE PERIOD ENDED 30 SEPTEMBER 2024

OPERATING ACTIVITIES
NOTE 10
CASH BACKED RESEVES

Cash Backed Reserve

Reserve Name	Opening Balance	Amended Budget Interest Earned	Actual Interest Earned	Amended Budget Transfers In (+)	Actual Transfers In (+)	Amended Budget Transfers Out (-)	Actual Transfers Out (-)	Amended Budget Closing Balance	Actual YTD Closing Balance
	\$	\$	\$	\$	\$	\$	\$	\$	\$
Employee Entitlements Reserve	177,148.64	4,739.00	0.00	0.00	0.00	0.00	0.00	181,887.64	177,148.64
Building & Infrastructure Reserve	941,595.30	25,191.00	0.00	0.00	0.00	(350,000.00)	0.00	616,786.30	941,595.30
Furniture, Fittings & Equipment Reserve	24,719.78	661.00	0.00	0.00	0.00	0.00	0.00	25,380.78	24,719.78
Plant Reserve	749,430.27	20,050.00	0.00	0.00	0.00	(180,000.00)	0.00	589,480.27	749,430.27
Health Reserve	102,974.01	2,755.00	0.00	0.00	0.00	0.00	0.00	105,729.01	102,974.01
Swimming Pool Reserve	20,970.35	561.00	0.00	0.00	0.00	0.00	0.00	21,531.35	20,970.35
Sustainable Environment Reserve	177,262.39	4,742.00	0.00	0.00	0.00	0.00	0.00	182,004.39	177,262.39
Town Planning & Development Reserve	74,508.35	1,993.00	0.00	0.00	0.00	0.00	0.00	76,501.35	74,508.35
HomesWest Joint Venture Housing Reserve	5,610.09	150.00	0.00	0.00	0.00	0.00	0.00	5,760.09	5,610.09
Road Infrastructure Reserve	569,730.93	15,242.00	0.00	40,000.00	0.00	0.00	0.00	624,972.93	569,730.93
Rec Centre Multi Purpose Reserve	556,992.15	14,901.00	0.00	125,000.00	0.00	0.00	0.00	696,893.15	556,992.15
Building Renewal Reserve	130,029.96	3,479.00	0.00	0.00	0.00	0.00	0.00	133,508.96	130,029.96
Independent Living Reserve	580,666.81	15,536.00	0.00	0.00	0.00	0.00	0.00	596,202.81	580,666.81
	4,111,639.03	110,000.00	0.00	165,000.00	0.00	(530,000.00)	0.00	3,856,639.03	4,111,639.03

KEY INFORMATION

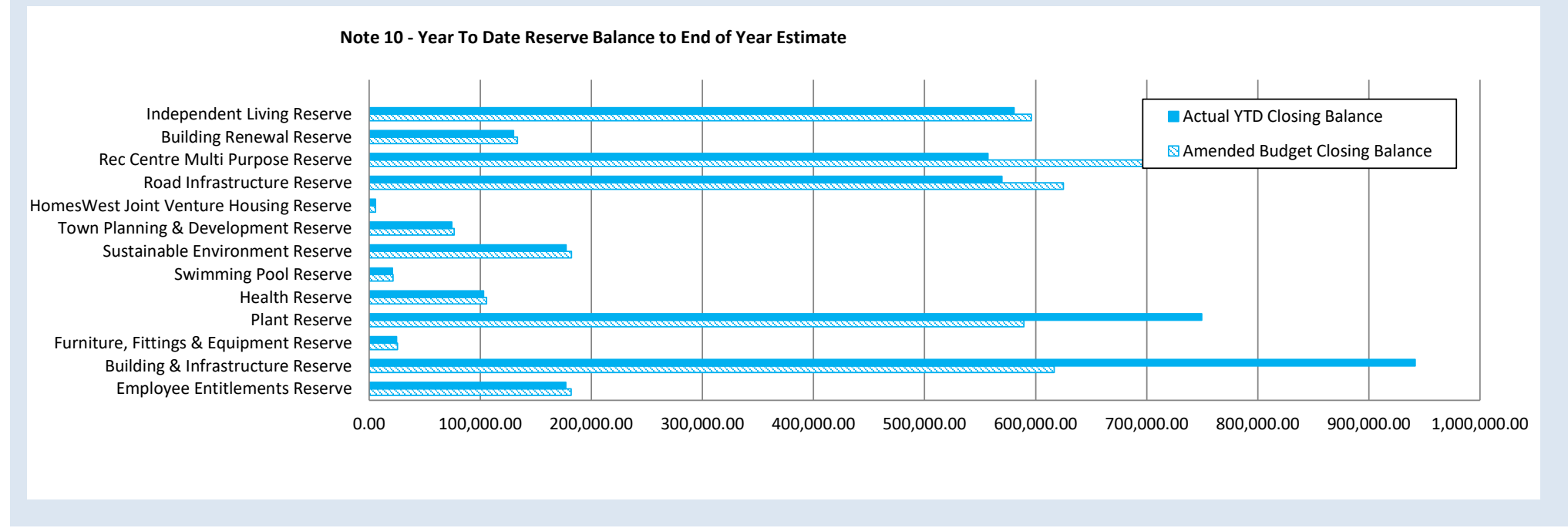

**SHIRE OF QUAIRADING
NOTES TO THE STATEMENT OF FINANCIAL ACTIVITY
FOR THE PERIOD ENDED 30 SEPTEMBER 2024**

**OPERATING ACTIVITIES
NOTE 11
OTHER CURRENT LIABILITIES**

Other Current Liabilities	Note	Opening Balance 1 Jul 2024	Liability Increase	Liability Reduction	Closing Balance 30 Sep 2024
		\$	\$	\$	\$
Other Liabilities					
- Contract Liabilities	12	68,952	0	0	68,952
- Capital Grant/Contribution Liabilities	13	169,695	6,600	0	176,295
Total Other liabilities		238,647	6,600	0	245,247
Less non-current unspent grants, contributions and reimbursements		0	0	0	0
Total current unspent grants, contributions and reimbursements		238,647	6,600	0	245,247
Employee Related Provisions					
Annual leave		120,960	0	0	120,960
Long service leave		33,441	0	0	33,441
Annual leave oncosts		17,260	0	0	17,260
Long service leave oncosts		4,424	0	0	4,424
Total Provisions		176,085	0	0	176,085
Total Other Current Liabilities					421,332

Amounts shown above include GST (where applicable)

KEY INFORMATION

PROVISIONS

Provisions are recognised when the Shire has a present legal or constructive obligation, as a result of past events, for which it is probable that an outflow of economic benefits will result and that outflow can be reliably measured.

Provisions are measured using the best estimate of the amounts required to settle the obligation at the end of the reporting period.

EMPLOYEE BENEFITS

Short-term employee benefits

Provision is made for the Shire’s obligations for short-term employee benefits. Short-term employee benefits are benefits (other than termination benefits) that are expected to be settled wholly before 12 months after the end of the annual reporting period in which the employees render the related service, including wages, salaries and sick leave. Short-term employee benefits are measured at the (undiscounted) amounts expected to be paid when the obligation is settled.

The Shire’s obligations for short-term employee benefits such as wages, salaries and sick leave are recognised as a part of current trade and other payables in the calculation of net current assets.

Other long-term employee benefits

The Shire’s obligations for employees’ annual leave and long service leave entitlements are recognised as provisions in the statement of financial position.

Long-term employee benefits are measured at the present value of the expected future payments to be made to employees. Expected future payments incorporate anticipated future wage and salary levels, durations of service and employee departures and are discounted at rates determined by reference to market yields at the end of the reporting period on government bonds that have maturity dates that approximate the terms of the obligations. Any re-measurements for changes in assumptions of obligations for other long-term employee benefits are recognised in profit or loss in the periods in which the changes occur. The Shire’s obligations for long-term employee benefits are presented as non-current provisions in its statement of financial position, except where the Shire does not have an unconditional right to defer settlement for at least 12 months after the end of the reporting period, in which case the obligations are presented as current provisions.

CONTRACT LIABILITIES

An entity’s obligation to transfer goods or services to a customer for which the entity has received consideration (or the amount is due) from the customer. Grants to acquire or construct recognisable non-financial assets to identified specifications be constructed to be controlled by the Shire are recognised as a liability until such time as the Shire satisfies its obligations under the agreement.

SHIRE OF QUAIRADING
 NOTES TO THE STATEMENT OF FINANCIAL ACTIVITY
 FOR THE PERIOD ENDED 30 SEPTEMBER 2024

NOTE 12
 GRANTS, SUBSIDIES AND CONTRIBUTIONS

Provider	Grant, Subsidies and Contributions Liability					Grants, Subsidies and Contributions Revenue			
	Liability 1 Jul 2024	Increase in Liability	Liability Reduction (As revenue)	Liability 30 Sep 2024	Current Liability 30 Sep 2024	Adopted Budget Revenue	Amended Annual Budget	Amended YTD Budget	YTD Actual Revenue
	\$	\$	\$	\$	\$	\$	\$	\$	\$
General purpose funding									
Grants Commission - General/Roads (WALGGC)	0	0	0	0	0	202,474	202,474	0	0
Grants Commission - Roads (WALGGC)	0	0	0	0	0	101,618	101,618	0	0
Law, order, public safety									
DFES Grant - Operating Bush Fire Brigade	0	0	0	0	0	44,725	44,725	0	4,780
Mitigation Activity Fund Grant Program - Round 2	67,500	0	0	67,500	67,500	67,500	67,500	16,866	0
Education and welfare									
Youth Week Grant	1,257	0	0	1,257	1,257	0	0	0	0
Recreation and culture									
Grant - Toddler Learn to Swim	0	0	0	0	0	2,500	2,500	0	0
NAIDOC Week Grant	0	0	0	0	0	1,350	1,350	0	0
Volunteering WA Grant	195	0	0	195	195	0	0	0	0
Transport									
Direct Grant (MRWA)	0	0	0	0	0	180,708	180,708	180,708	0
	68,952	0	0	68,952	68,952	600,874	600,874	197,574	4,780
Contributions									
TOTALS	68,952	0	0	68,952	68,952	600,874	600,874	197,574	4,780

**SHIRE OF QUAIRADING
NOTES TO THE STATEMENT OF FINANCIAL ACTIVITY
FOR THE PERIOD ENDED 30 SEPTEMBER 2024**

**NOTE 13
CAPITAL GRANTS, SUBSIDIES AND CONTRIBUTIONS**

Provider	Capital Grants, Subsidies and Contributions Liability					Capital Grants, Subsidies and Contributions Revenue			
	Liability 1 Jul 2024	Increase in Liability	Liability Reduction (As revenue)	Liability 30 Sep 2024	Current Liability 30 Sep 2024	Adopted Budget Revenue	Amended Annual Budget	Amended YTD Budget	YTD Actual Revenue
	\$	\$	\$	\$	\$	\$	\$	\$	\$
Law, order, public safety									
South Caroling Water Tank	0	0	0	0	0	4,219	4,219	0	0
Solar Electronic Fire Danger Signs (Capital) - DRF Funded	0	0	0	0	0	15,000	15,000	0	0
Community amenities									
Electric Car Charging Station (Capital)	0	6,600	0	6,600	6,600	6,926	6,926	1,728	0
Recreation and culture									
LRCI Grant Phase 3 - Construction Hall Carpark	0	0	0	0	0	0	0	0	(13,171)
LRCI Grant Phase 4 - Greater Sports Ground - Multi Use Courts	0	0	0	0	0	393,347	393,347	98,340	0
LRCIP Grant Phase 3 - Community Park	0	0	0	0	0	0	0	0	(11,562)
CBH grant - Multi Use Courts Resurfacing	7,500	0	0	7,500	7,500	0	0	0	0
Greater Sports Ground (Gsc) - Netball/Basketball Courts (Csrf Funded) - Income	0	0	0	0	0	125,000	125,000	0	0
Transport									
R2R Grant - Dangin Terrace (R2R)	0	0	0	0	0	96,875	96,875	24,216	0
R2R Grant - Walker Street (R2R)	0	0	0	0	0	60,000	60,000	15,000	0
R2R Grant - Subbine Rd, Cubbine (R2R)	0	0	0	0	0	81,138	81,138	20,289	0
R2R Grant - Kellerberrin-Yoting Rd (R2R)	0	0	0	0	0	90,000	90,000	22,500	0
R2R Grant - Quairading Corrigin Road (R2R)	0	0	0	0	0	138,912	138,912	34,728	0
R2R Grant - Hayes Road (R2R)	0	0	0	0	0	80,000	80,000	19,998	0
R2R Grant - Andrews Road (R2R)	0	0	0	0	0	80,554	80,554	0	0
RRG Grant - Quairading - Corrigin Road 21/22	74,639	0	0	74,639	74,639	0	0	0	0
RRG Grant - Quairading - Corrigin Road 22/23	58,159	0	0	58,159	58,159	0	0	0	0
RRG Grant - Quairading - Corrigin Road 23/24	0	0	0	0	0	92,006	92,006	0	0
RRG Grant - Bulyee - Quairading Road 24/25	0	0	0	0	0	369,888	369,888	0	0
RRG Grant - Old Beverley East Road 24/25	0	0	0	0	0	163,063	163,063	0	0
LRCIP Grant Phase 3 - Mt Stirling Rd Resheet	0	0	0	0	0	0	0	0	(3,875)
LRCIP Grant Phase 4 - Old Beverley East Road	0	0	0	0	0	226,889	226,889	56,721	0
WSFN Grant - Dangin - Mears Development Funds	29,398	0	0	29,398	29,398	24,752	24,752	6,188	0
	169,695	6,600	0	176,295	176,295	2,048,569	2,048,569	299,708	(28,607)
Capital Contributions									
Contribution towards Comminty Car Replacement	0	0	0	0	0	17,812	17,812	0	0
	0	0	0	0	0	17,812	17,812	0	0
Total capital grants, subsidies and contributions	169,695	6,600	0	176,295	176,295	2,066,381	2,066,381	299,708	(28,607)

**SHIRE OF QUAIRADING
NOTES TO THE STATEMENT OF FINANCIAL ACTIVITY
FOR THE PERIOD ENDED 30 SEPTEMBER 2024**

**NOTE 14
BONDS & DEPOSITS AND TRUST FUNDS**

In previous years, bonds and deposits were held as trust monies. They are still reported in this Note but also included in Restricted Cash - Bonds and Deposits and as a current liability in the books of Council.

Trust funds held at balance date over which the Shire has no control and which are not included in this statement are as follows:

Description	Opening Balance 01 Jul 2024	Amount Received	Amount Paid	Closing Balance 30 Sep 2024
		\$	\$	\$
Restricted Cash - Bonds and Deposits				
Building Services Levy (BSL)	2,581.57	0.00	(2,646.93)	(65.36)
Construction Training Fund (CTF)	588.53	0.00	0.00	588.53
Councillor Nomination Fee	0.00	0.00	0.00	0.00
Key, Hall & Equipment Bonds	4,458.55	1,700.00	(200.00)	5,958.55
Unclaimed Monies	1,152.50	0.00	0.00	1,152.50
Department of Transport Licensing TransWA	(4,784.19)	115,580.10	(115,580.10)	(4,784.19)
Other Bonds & Deposits/Cuneata Rise	0.00	0.00	0.00	0.00
Caravan Park Cabin Bonds	39,887.30	18,601.00	(300.00)	58,188.30
Community Bus Bonds	0.00	0.00	0.00	0.00
Rental Bonds	541.30	0.00	0.00	541.30
Animal Trap Bonds	6,966.00	1,056.00	(400.00)	7,622.00
	0.00	0.00	0.00	0.00
Sub-Total	51,391.56	136,937.10	(119,127.03)	69,201.63
Trust Funds				
Nil	0.00	0.00	0.00	0.00
Sub-Total	0.00	0.00	0.00	0.00
	51,391.56	136,937.10	(119,127.03)	69,201.63

KEY INFORMATION

--

SHIRE OF QUAIRADING

NOTES TO THE STATEMENT OF FINANCIAL ACTIVITY
FOR THE PERIOD ENDED 30 SEPTEMBER 2024

NOTE 15
EXPLANATION OF SIGNIFICANT VARIANCES

The material variance thresholds are adopted annually by Council as an indicator of whether the actual expenditure or revenue varies from the year to date budget materially.

The material variance adopted by Council for the 2024/25 year is \$10,000 and 10%.

Favourable Variance. ▲
Unfavourable Variance. ▼

Community Amenities	Var. \$	Var. %	Var. ▲ ▼	Significant Var. S	Timing/ Permanent	Explanation of Variance
Revenue from operating activities						
Governance	0				Permanent	
General Purpose Funding - Other	(33,706)	(76%)	▼	S	Timing	24/25 FY funds received in advance - June payment
Law, Order and Public Safety	(30,723)	(52%)	▼	S	Timing	Negative variance a combination of CESM/BRMP reimbursement not being received and positive Mitigation Activity Fund Grant being received earlier than budgeted.
Community Amenities	100,351	173%	▲	S		Timing of budget allocation for Domestic Refuse Collection Charges.
Transport	(204,445)	(97%)	▼	S	Timing	Outstanding grants to be paid
Other Property and Services	(11,421)	(91%)	▼	S	Permanent	
Expenditure from operating activities						
Governance	87,188	52%	▲	S	Timing	
General Purpose Funding	16,360	54%	▲	S	Timing	
Law, Order and Public Safety	76,313	50%	▲	S	Timing	
Health	(73,391)	(54%)	▼	S	Timing	
Education and Welfare	45,442	50%	▲	S	Timing	
Community Amenities	144,275	50%	▲	S	Timing	
Recreation and Culture	158,892	53%	▲	S	Timing	
Transport	514,931	59%	▲	S	Timing	
Economic Services	154,058	64%	▲	S	Timing	
Other Property and Services	(253,031)	(348%)	▼	S	Timing	
INVESTING ACTIVITIES						
Capital Grants, Subsidies and Contributions	(328,315)	(110%)	▼	S	Timing	
Proceeds from Disposal of Assets	(138,863)	(57%)	▼	S	Timing	Items still to be disposed of
Land and Buildings	124,718	62%	▲	S	Timing	Work not yet completed
Infrastructure Assets - Roads	371,013	86%	▲	S	Timing	Projects not yet completed, see capital Works Note 8.
Infrastructure Assets - Other	81,647	63%	▲	S	Timing	Projects not yet completed, see capital Works Note 8.

SHIRE OF QUAIRADING - ANNUAL BUDGET REVIEW
 NOTES TO THE STATEMENT OF FINANCIAL ACTIVITY
 FOR THE PERIOD ENDED 30 SEPTEMBER 2024

NOTE 16
BUDGET AMENDMENTS

GL Code	IE Code	Job #	Description	Council Resolution	Classification	Non Cash Adjustment	Increase in Available Cash	Decrease in Available Cash	Amended Budget Running Balance
			Budget Adoption		Closing Surplus/(Deficit)	\$	\$ 24,534	\$	\$ 24,534
						0	24,534	0	24,534

KEY INFORMATION

**SHIRE OF QUAIRADING
NOTES TO THE STATEMENT OF FINANCIAL ACTIVITY
FOR THE PERIOD ENDED 30 SEPTEMBER 2024**

**NOTE 17
CARAVAN PARK**

Caravan Park Profit and Loss	YTD Bookings	YTD Actual	YTD Budget (Amended)	Annual Budget (Original)	Annual Budget (Amended)	Annual (Amd) Var %
INCOME						
Caravan Park Charges	143	\$ 15,071.63	\$ 14,994.00	\$ 60,000.00	\$ 60,000.00	25%
Cabin and Unit Charges	224	\$ 37,359.91	\$ 32,487.00	\$ 130,000.00	\$ 130,000.00	29%
Fees, Charges & Reimbursements		\$ 100.01	\$ -	\$ -	\$ -	0%
TOTAL INCOME	367	\$ 52,531.55	\$ 47,481.00	\$ 190,000.00	\$ 190,000.00	28%
EXPENDITURE						
Caravan Park						
Salaries & Wages		\$ -	\$ 3,993.00	\$ 15,990.00	\$ 15,990.00	0%
Materials & Contracts		\$ 2,085.32	\$ 2,904.00	\$ 11,640.00	\$ 11,640.00	18%
Utilities & Insurance		\$ 1,155.21	\$ 3,417.00	\$ 13,700.00	\$ 13,700.00	8%
Caravan Park Total		\$ 3,240.53	\$ 10,314.00	\$ 41,330.00	\$ 41,330.00	8%
Cabins (3x 2 bedroom Cabins)						
Salaries & Wages		\$ -	\$ 5,742.00	\$ 23,025.00	\$ 23,025.00	0%
Materials & Contracts		\$ -	\$ 630.00	\$ 2,532.00	\$ 2,532.00	0%
Utilities & Insurance		\$ 3,429.83	\$ 2,672.00	\$ 10,757.00	\$ 10,757.00	32%
Cabins Total		\$ 3,429.83	\$ 9,044.00	\$ 36,314.00	\$ 36,314.00	9%
Caretaker Reception						
Salaries & Wages		\$ 3,517.25	\$ 2,397.00	\$ 9,594.00	\$ 9,594.00	37%
Materials & Contracts		\$ 244.50	\$ 222.00	\$ 892.00	\$ 892.00	27%
Utilities & Insurance		\$ 1,286.04	\$ 1,660.00	\$ 6,667.00	\$ 6,667.00	19%
Caretaker Reception Total		\$ 5,047.79	\$ 4,279.00	\$ 17,153.00	\$ 17,153.00	29%
Units (4x 1 bedroom units)						
Salaries & Wages		\$ -	\$ 2,073.00	\$ 8,315.00	\$ 8,315.00	0%
Materials & Contracts		\$ -	\$ 210.00	\$ 844.00	\$ 844.00	0%
Utilities & Insurance		\$ 780.32	\$ 275.00	\$ 1,109.00	\$ 1,109.00	70%
Units Total		\$ 780.32	\$ 2,558.00	\$ 10,268.00	\$ 10,268.00	8%
TOTAL EXPENDITURE		\$ 12,498.47	\$ 26,195.00	\$ 105,065.00	\$ 105,065.00	12%
Closing Funding Surplus(Deficit)		\$ 40,033.08	\$ 21,286.00	\$ 84,935.00	\$ 84,935.00	47%

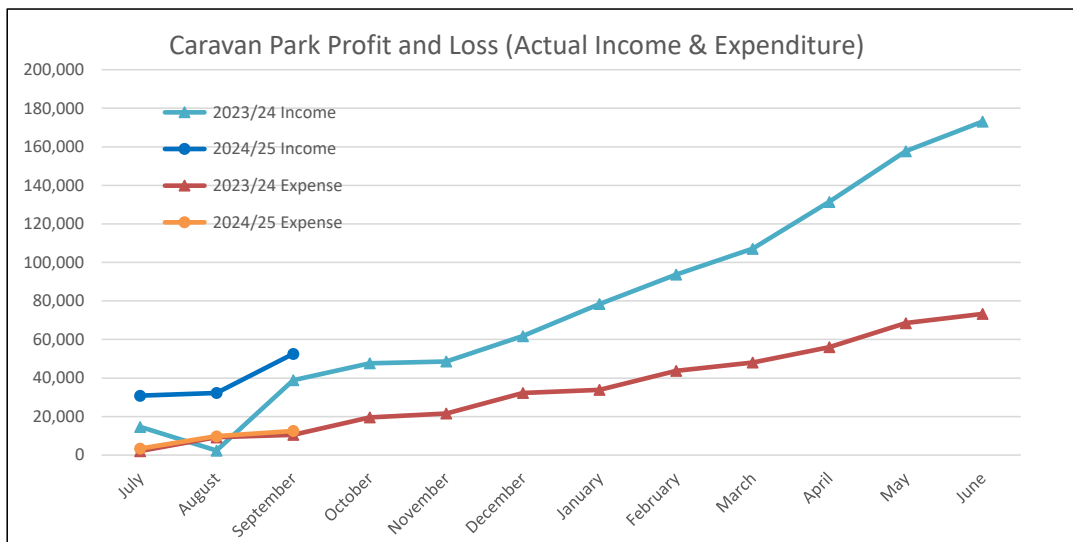



11.2 Accounts for Payment - September 2024

Responsible Officer Tricia Brown, Executive Manager, Corporate Services

Reporting Officer Cynthia Lowe, Senior Finance Officer

Attachments

1. Attachment (i) List of Accounts September 2024 [↓](#) 
2. Attachment (ii) Transport Takings September 2024 [↓](#) 
3. Attachment (iii) Credit Card Reconciliation September 2024 [↓](#) 

Voting Requirements Simple Majority

Disclosure of Interest Reporting Officer: Nil
Responsible Officer: Nil

RESOLUTION: OCM 062-24/25

Moved: Cr TJ Stacey

Seconded: Cr JC Hayes

That Council note the following:

1. That schedule of accounts for September 2024 covering EFT 14379 to EFT 14478 totalling \$878,517.90 be received (Attachment i);
2. That police licensing payments for the month of August 2024 totalling \$42,779.20 be received (Attachment ii); and
3. That fund transfers to the corporate credit card for August 2024 totalling \$7,991.69 be received (Attachment iii); and
4. That net payroll payments for the month of August 2024 totalled \$138,863.14; and
5. That the lease payments for the month of August 2024 totalled \$1,225.58 for the CESM vehicle lease.

FOR: Crs JN Haythornthwaite, TJ Stacey, BR Cowcill, RC Faltyn, EV Gom, JC Hayes and JR Hippisley

AGAINST: Nil

CARRIED 7/0

IN BRIEF

Payments are as per attachments (i), (ii) and (iii)

MATTER FOR CONSIDERATION

Note the accounts paid during September 2024

BACKGROUND

Council has delegated to the Chief Executive Officer the exercise of power to make payments from its municipal or trust funds. In accordance with regulation 13(1) of the Local Government (Financial Management) Regulations 1996 a list of accounts paid by the CEO is to be prepared each month and presented to the Council at the next ordinary meeting of the Council after the list is prepared.

STATUTORY ENVIRONMENT

Local Government (Financial Management) Regulations 1996

Local Government Act 1995

POLICY IMPLICATIONS

Corporate Credit Card Policy

Purchasing Policy

Delegation 1.1.13: Payments from the municipal or trust funds

FINANCIAL IMPLICATIONS

Payment from Council’s municipal fund. Expenditure as per delegated authority and included in the 2024/2025 budget.

Payments made for the 2024/25 year in the payments List have been included in Council’s budget in accordance with section 6.8 of the Local Government Act 1995.

ALIGNMENT WITH STRATEGIC PRIORITIES

- 5.3 Governance & Leadership:** Provide informed and transparent decision making that, meets our legal obligations, and the needs of our diverse community
- 5.4 Governance & Leadership:** Implement systems and processes that meet legislative and audit obligations

CONSULTATION

Nil

RISK MANAGEMENT PRIORITIES

This report addresses the following identified Strategic Risk Management Priorities:

Financial misconduct by (a) a Shire employee, and (b) an executive/office holder results in financial, legal and/or reputational damage.

RISK ASSESSMENT

	Option 1
Financial	Low <i>Given Purchasing / Procedures followed, together with Management Separation of acceptance of duties and Processes in place.</i>
Health	Low
Reputation	Low Creditors reviewed weekly and paid in accordance to agreed terms.
Operations	Low
Natural Environment	Low

	Consequence				
Likelihood	Insignificant	Minor	Moderate	Major	Critical
Rare	LOW Accept the risk Routine management	LOW Accept the risk Routine management	LOW Accept the risk Routine management	MEDIUM Specific responsibility and treatment	HIGH Quarterly senior management review
Unlikely	LOW Accept the risk Routine management	LOW Accept the risk Routine management	MEDIUM Specific responsibility and treatment	MEDIUM Specific responsibility and treatment	HIGH Quarterly senior management review
Possible	LOW Accept the risk Routine management	MEDIUM Specific responsibility and treatment	MEDIUM Specific responsibility and treatment	HIGH Quarterly senior management review	HIGH Quarterly senior management review
Likely	MEDIUM Specific responsibility and treatment	MEDIUM Specific responsibility and treatment	HIGH Quarterly senior management review	HIGH Quarterly senior management review	EXTREME Monthly senior management review
Almost certain	MEDIUM Specific responsibility and treatment	MEDIUM Specific responsibility and treatment	HIGH Quarterly senior management review	EXTREME Monthly senior management review	EXTREME Monthly senior management review

COMMENT

The payment listing for September 2024 are included in **Attachment (i)**

11.1 (i) List Of Accounts - September 2024					
Chq/EFT	Date	Name	Description	Amount	Funded
EFT14379	02/09/2024	MCINTOSH & SON WA	NEW HOLLAND T5S.90 TRACTOR FOR GARDENS INCL FRONT END LOADER, 90HP, AS PER QUOTE CKF049	82500.00	
EFT14380	02/09/2024	Infocouncil Pty Ltd	INFOCOUNCIL - ANNUAL LICENSE FEE 01/07/2024 - 30/06/2024 & ANNUAL HELP DESK FEE	11052.18	
EFT14381	06/09/2024	TILAH TEKERE NGATAIERUS	REFUND OF RENTAL BOND UNIT 1/19 GILLETT STREET, QUAIRADING LESS OUTSTANDING ELECTRICITY INVOICES	96.68	FULLY
EFT14382	13/09/2024	QUAIRADING EARTHMOVING CO.	3500m2 OF GRAVEL - PUSHED WITH D9 DOZER - ANDREWS ROAD	6616.50	PARTIALLY
EFT14383	13/09/2024	COUNTRY COPIERS	ADMIN COPIER METER READING 07/07/24 - 12/08/24	240.90	
EFT14384	13/09/2024	WESTERN AUSTRALIAN TREASURY CORPORATION	LOAN 119 REPAYMENTS & INTEREST REPAYMENT	8096.35	
EFT14385	13/09/2024	BURGESS RAWSON	WATER CORP ACCT#9018402607 - USAGE AND RATES - QCRC 1(QUAIRADING -YORK ROAD LOT 366) WATER CORP ACCT#9010881981 - RATES - HEAL STREET LOT WESTRAIL PLAN 1422 01/07/24 31/08/24	584.19	
EFT14386	13/09/2024	COMMUNITY RESOURCE CENTRE -	GYM MANAGEMENT FEE 2024/25, BUILDING MANAGEMENT FEE 2024/25, CRC MEMBERSHIP 2024/25	17179.80	
EFT14387	13/09/2024	QUAIRADING MEDICAL PRACTICE (GREAT CARE HEALTH)	PRE- EMPLOYMENT MEDICAL - DEPOT GENERAL HAND/PLANT OPERATOR	150.70	

EFT14388	13/09/2024	WATER CORPORATION	<p>WATERCORP ACCOUNT #9007856072 SUPPLY & USAGE FOR C/PARK, Q SWIMMING POOL, PARKS, GARDENS & RESERVES FOR THE PERIOD 10/06/2024 - 15/08/2024</p> <p>WATERCORP ACCOUNT #9007856080 SUPPLY & USAGE FOR THE PERIOD 10/6/24 - 15/8/24 - 252 KL USED - Q C/PARK</p> <p>WATERCORP ACCOUNT #9007856099 SUPPLY & USAGE FOR THE PERIOD 10/6/24 - 15/8/24 - 643KL USED - Q BOWLING CLUB</p> <p>WATERCORP ACCOUNT #9007855379 SUPPLY & USAGE FOR THE PERIOD 10/6/24 - 15/8/24 - 8KL USED - MEDICAL CENTRE</p> <p>WATERCORP ACCOUNT #9007859417 SUPPLY & USAGE FOR THE PERIOD 11/6/24 - 15/8/24 - 1KL USED - 31 DALL STREET</p> <p>WATERCORP ACCOUNT #9007856101 SUPPLY & USAGE FOR THE PERIOD 10/6/24 - 15/8/24 - 11KL USED - QUAIRADING SHIRE HALL</p> <p>WATERCORP ACCOUNT #9007856507 SUPPLY & USAGE FOR THE PERIOD 10/6/24 - 15/15/8/24 - OKL USED - VET CLINIC</p> <p>WATERCORP ACCOUNT #9007856021 SUPPLY & USAGE FOR THE PERIOD 10/6/24 - 15/8/24 - 0KL USED - OVAL & GROUNDS</p> <p>WATERCORP ACCOUNT #9007859257 SUPPLY & USAGE FOR THE PERIOD 10/6/24 - 15/8/24 - 41KL USED - 19 POWELL CRESCENT</p> <p>WATERCORP ACCOUNT #9007858182 SUPPLY & USAGE FOR THE PERIOD 11/06/2024 - 16/08/2024 - 0KL USED - DAYCARE CENTRE</p> <p>WATERCORP ACCOUNT #9007856224 SUPPLY & USAGE FOR THE PERIOD 11/06/2024 - 16/08/2024 - 212KL USED - AKV COMMON AREA</p> <p>WATERCORP ACCOUNT #9007854421 SUPPLY & USAGE FOR THE PERIOD 11/6/24 - 15/8/24 - 46KL USED - 8 DALL STREET</p> <p>WATERCORP ACCOUNT #9007856013 SUPPLY & USAGE FOR THE PERIOD 10/06/24 - 15/08/24 - 20KL USED - 74 MCLENNAN STREET</p>	13913.38	PARTIALLY
----------	------------	-------------------	--	----------	-----------

			<p>WATERCORP ACCOUNT #9007858393 SUPPLY & USAGE FOR THE PERIOD 10/6/24 - 15/8/24 - 22KL USED - 50A SUBURBAN ROAD</p> <p>WATERCORP ACCOUNT #9007859409 SUPPLY & USAGE FOR THE PERIOD 1/7/24 - 31/8/24 - 9KL USED - 50B SUBURBAN ROAD</p> <p>WATERCORP ACCOUNT #9007856128 SUPPLY & USAGE FOR THE PERIOD 11/6/24 - 16/8/24 - 74KL USED - STANDPIPES</p> <p>WATERCORP ACCOUNT #9007858457 SUPPLY & USAGE FOR THE PERIOD 10/6/24 - 16/8/24 - 18KL USED - 64 CORALING STREET</p> <p>WATERCORP ACCOUNT #9007858158 SUPPLY & USAGE FOR THE PERIOD 11/6/24 - 16/8/24 - 47KL USED - 19 GILLET STREET</p> <p>WATERCORP ACCOUNT #9007856179 SUPPLY & USAGE FOR THE PERIOD 11/6/24 - 16/8/24 - 33KL USED - MCLEAY PARK</p> <p>WATERCORP ACCOUNT #9007858908 SUPPLY & USAGE FOR THE PERIOD 11/6/24 - 16/8/24 - 1KL USED - YOUTH CENTRE</p> <p>WATERCORP ACCOUNT #9007856136 SUPPLY & USAGE FOR THE PERIOD 11/6/24 - 16/8/24 - 25KL USED - SHIRE ADMIN BUILDING</p> <p>WATER CONNECTION FEE - SOUTH CAROLING FIRE WATER TANK - STANDPIPES</p>		
EFT14389	13/09/2024	BOB WADDELL & ASSOCIATES PTY LTD	<p>ASSISTANCE WITH THE 2023/24 ANNUAL FINANCIAL REPORT INCLUDING EOY ASSET WORK</p> <p>2024/25 RATES MANAGEMENT: 1HRS SERVICE PROVIDED BY TARA (W/E: 25/08/24) RATES QUERIES & EMAILS</p>	6644.00	
EFT14390	13/09/2024	BENTNAIL BUILDING & MAINTENANCE	<p>GRAVEL SAMPLING EXCAVATOR HIRE - BULYEE QDG RD - RRG002 - REGIONAL ROAD GROUP</p> <p>HIRE OF EXCAVATOR FOR FUNERAL 5/9/24</p>	759.00	PARTIALLY
EFT14391	13/09/2024	TRUCK CENTRE (WA) PTY LTD	<p>SUPPLY OF 1 X CW 26 460 6-WHEEL TIP TRUCK AS PER QUOTE HTr2023000315 OF 11 NOV 2023, TRADE-IN, 2012 UD GW26 400 6x4, REGO Q5122</p>	203588.75	

EFT14392	13/09/2024	LGISWA WESTERN AUSTRALIAN LOCAL GOVERNMENT ASSOCIATION AS TRUSTEE FOR LGISWA	LGIS PROPERTY- 30.06.24 - 30.06.25 -1ST INSTALLMENT - POLICY #000074 - RAILWAY STATION, SHIRE HALL, SHIRE HALL PORTABLE GENERATOR, SHIRE HALL - ART WORK, SHIRE ADMINISTRATION OFFICE, CARAVAN PARK SINGLE PERSON UNITS, CABIN 1, 2, 3, CARAVAN PARK RECEPTION & RESIDENCE, VET CLINIC, 7 EDWARDS WAY, DOCTORS SURGERY & RESIDENCE, TENNIS CLUB CLUBHOUSE & COURTS, FENCING & FLOOD LIGHTING,BOWLING CLUB INCL SPORTS LIGHTING, BOWLING CLUB - SAND FILLED SYNTHETIC GREEN, SWIMMING POOL COMPLEX INCL KIOSK, CHANGEROOMS, BOWLS, TANKS ETC, SPORTS GROUND - CHANGEROOMS, COMMUNITY BUILDING, TRANSPORTABLE LADIES CHANGE ROOMS, 19 POWELL CRESCENT, 64 CORALING, 19 GILLETT STREET 4 X UNITS, LIBRARY, 31 DALL STREET, 190 MCLENNAN STREET RESIDENCE, SCOUT HALL (DRIVE IN SITE) SPORTING CLUBHOUSE, FACILITIES, LIGHTING, 74 MCLENNAN STREET, 50A & 50B SUBURBAN ROAD, 28 REID STREET, BOWLING CLUB, AIRFIELD TRANSFER SHED, AIRCRAFT HANGAR / STORAGE SHED, 8 DALL STREET, PANTAPIN HALL, YOUTH CENTRE, TOURIST LAYBY ABLUTIONS & HEAL ST TOILET, TOURIST LAYBY GAZEBO, 14 REID STREET, MACHINERY SHED & SHELTER, RECYCLING BUILDING / OFFICE / SHED, CRC, CRC GYM EQUIPMENT, SILENCED 3 PHASE BACKUP GENERATOR, PRE-SHOOL BUILDING INCL PLAYGROUND, CEMETERY TOILET BLOCK, CEMETERY GAZEBO, CEMETERY SHELTER, GOLF CLUBROOMS, GOLF BUGGY SHED, GOLF MACHINERY SHED, GOLF SHED, TOAPIN WEIR TOILETS, PIT TOILET NATURE RESERVE, CARAVAN PARK ABLUTIONS / TOILETS, PART DEPOT TOOL SHED, AGIRCULTURAL BUILDING - PCYC HALL, UNIT 1 - 8 ARTHUR KELLY VILLAGE, UNIT FOOTBALL CHANGE ROOMS, CARAVAN PARK AMENITIES & KITCHEN, CRIB ROOM BUILDING, TOURIST LAYBY SITTING AREA, PART DEPOT MACHINERY SHED, SPORTS GROUND STEEL FRAME SHELTER, AG FEMALE & MALE TOILETS, PCYC SHED, GRAIN EXPO SHED, CARPORT ARTHUR KELLY VILLAGE, DEPOT WORKSHOP (NEW) - INCLUDES CAT MOTEL, SWIMMING POOL PLANT ROOM (NEW), WAMENUSKING SPORTS CLUB BUILDING, SWIMMING POOL SHED, WASTE & RECYCLING FACILITY OFFICE -	145492.49	
----------	------------	--	---	-----------	--

			WASTE & RECYCLING FACILITY AMENITIES (TOILET BLOCK), BUILDERS SHED AT DEPOT, FUEL AWNING, KWIRRADING KOORT COMMUNITY PARK, NORTH QUAIRADING FIRE SHED, 4 SOUTH QUAIRADING FIRE SHED, WAMENUSKING 1 BAY FIRE SHED WITH TOILET, DOODENANNING FIRE STATION, RAM SHED / WOOL PAVILLION, DANGIN NORTH ROAD, DANGIN MEARS ROAD, DANGIN MEARS ROAD, DANGIN MEARS ROAD, QUAIRADING SOUTH ROAD, OLD BEVERLEY ROAD, QUAIRADING - CORRIGIN ROAD, BADJALING SOUTH ROAD, BADJALING NORTH ROAD, BADJALING NORTH ROAD, SOLOMON ROAD, MOUNT STIRLING ROAD, CUBBINE ROAD, CUNDERDIN - QUAIRADING ROAD, HAYES ROAD, CUBBINE ROAD, GEYER STREET, MISCELLANEOUS STRUCTURES AND EQUIPMENT, 4 LOSS OF GROSS REVENUE & / OR RENT, ADDITIONAL INCREASED COST OF WORKING, CLAIM PREPARATION COSTS, GENERAL PROPERTY, LGIS VEHICLE, COMMUNITY BUS, MAZA BT UTE, CHERRY PICKER TRAILER, SINGLE DRUM ROLLER, CASE BACKHOE, MULTIPAC ROLLER, JOHN DEERE TRACTOR, CAT GRADER, BOX TRAILER, HITACHI EXCAVATOR AND MULCHING HEAD, CAT GRADER, 2018 MITSUBISHI TRITON, 2018 MULCHING UTE, ROAD BROOM, POLMAC TRAILERS, 2008 ISUZU FIRE TENDER NORTH QUAIRADING, 2018 ISUZU D-MAX UTE, LGIS VEHICLE, 2014 MAZDA BT-50, LOW LOADER DROP DECK TRAILER, TRI AXLE SIDE TIPPER, 2020 ISUZU D-MAX UTE, 2020 MAZDA CX-9, NISSAN FORKLIFT, TOYOTA CAMRY (COMMUNITY CAR), NISSAN TRUCK, 2024 MAZDA BT-50, 2012 HINE RURAL FIRE TRUCK (BALKULING/DOODY), 2012 HINE RURAL FIRE TRUCK (WAMENUSKING), MITSUBISHI FUSO TRUCK, FAST TRACK BUSHFIRE TRAILER, 2016 ISUZU FTS 800, 2015 CAT HIGHWAY TRUCK, 2016 SIDE TIP PIG TRAILER, 2016 CAT LOADER, 2018 HINO TIP TRUCK, 2020 FORD RANGER, AMMANN ARS DRUM ROLLER, 4 2019 BOBCAT TRACK LOADER, 2012 TIPPER CREW CAB, 2023 NISSAN QASHQAI, PERUZZO PANTHER MOWER, FERRIS MOWER, JCB BACKHOE, SANTA FE, HINO FIRE TENDER CENTRAL, HINO FIRE TENDER SOUTH QUAIRADING, LIABILITY, CORPORATE TRAVEL, VOLUNTARY WORKERS, BUSH FIRE, BRIGADE MEMBERS, VEHICLE INSURANCE, LGIS INSURANCE, EM MANAGEMENT - EMPLOYEE COSTS, LGIS INSURANCE		
EFT14393	13/09/2024	DEAN ROBERT MASTIN	REIMBURSEMENT FOR 1x AOS REAR SEAT ORG, 1x AOS DASH ORGANISER FOR 2024 MAZDA BT-50	150.00	
EFT14394	13/09/2024	GREAT SOUTHERN FUEL SUPPLIES	20kg PREMIUN HEAVY DUTY GREASE PART - DEPOT	317.98	
EFT14395	13/09/2024	WA CONTRACT RANGER SERVICES PTY LTD	CONTRACT RANGER SERVICES FOR THE MONTH OF AUGUST 2024 - DATES SERVICED 15/08/24 & 22/08/24	721.87	
EFT14396	13/09/2024	NORTHAM MAZDA	4x4 DUAL CAB UTE, EMWS VEHICLE - WORK SUPERVISOR VEHICLE	57311.20	

EFT14397	13/09/2024	R MUNNS ENGINEERING CONSULTING SERVICES	EXPERIENCED RAMM CONSULTANT, FOR UPDATING OF RAMM DATA 2022, 2023, 2024 AND OVERVIEW OF RAMM CAPABILITIES	1543.63	
EFT14398	13/09/2024	LOCAL GOVERNMENT PROFESSIONALS	2024 - 2025 FULL MEMEBERSHIP TO LG PROFESSIONALS - EO	560.00	
EFT14399	13/09/2024	SHELLEYANNE RUSSELL	REIMBURSEMENT FOR NEW LEATHER OFFICE CHAIR FOR DEPOT	205.95	
EFT14400	13/09/2024	AMPAC DEBT RECOVERY (WA) PTY LTD	AMPAC DEBT RECOVERY COSTS FOR AUGUST 2024	10.00	FULLY
EFT14401	13/09/2024	AFGRI EQUIPMENT AUSTRALIA	REPLACEMENT HYDRAULIC HOSE , MULCHING HEAD	939.40	
EFT14402	13/09/2024	BUNNINGS GROUP LIMITED	30L VACUM CLEANER, COMMUNITY BUILDING x1 LAVENDER PLANT 180mm STOECHAS AVONVIEW VEHILCLE WASHING BROOMS, POTHOLING BROOMS	401.11	
EFT14403	13/09/2024	JASON KEITH LILLEYMAN	CARPET CLEANING , 64 CORALING ST	455.00	
EFT14404	13/09/2024	FITONIA PTY ATF THE SILVERSPRING TRUST T/AS T J DEPIAZZI & SONS	50mL WHITE WASHED PLAYGOUND SAND INCLUDES DELIVERY TO QDG - KWIRRADING KOORT	5181.79	
EFT14405	13/09/2024	GLOBAL SPILL CONTROL PTY LTD	DEPOT - BUNDING FOR CHEMICAL STORAGE	2386.77	
EFT14406	13/09/2024	HUTTON & NORTHEY SALES	HYDRAULIC OIL FOR 2019 BOBCAT TRACK LOADER - DEPOT	173.86	
EFT14407	13/09/2024	PHILIP SWAIN	EHO SERVICES FOR THE PERIOD 06/07/24 - 15/08/24	2914.54	

EFT14408	13/09/2024	ELDERS QUAIRADING	74 MCLENNAN ST - DISHWASHER TOWN HALL - FRIDGE/FREEZER - REPLACE LG IN KITCHEN U1 GILLET ST - FRIDGE/FREEZER REPLACEMENT GAS COOKTOP 1 X CARTON, TORK HAND TOWELS, 1 X CARTON, TORK TOILET ROLLS - C/PARK REPLACEMENT FIRE TANK, STH CAROLING HALL, AS PER QUOTE TO MATT RICHARDS	5706.90	
EFT14409	13/09/2024	REGIONAL FIRE & SAFETY	COMMUNITY BUS - REPLACEMENT FIRE EXTINGUISHER & HARNESS	333.30	FULLY
EFT14410	13/09/2024	GREENWOOD OPERATIONS PTY LTD	DAYCARE - REPAIR EMERGENCY EXIT LIGHT SIGNAGE, CARAVAN PK - ATTEND TO RCD TRIPPING IN LADIES ABLUTION S, REPLACED FAULTY LED BATTENS AND EXHAUST FANS. REPLACED HOB IN KITCHEN OVAL - ATTEND TO FLOODLIGHT, REPAIR DAMAGED CABLE, REPOSITION AND SECURE FLOODLIGHT, BORE FIELD- BORE PUMPS, RECONNECT AND TEST BORE PUMP OPERATION COMMUNITY BUILDING- REPLACE FAULTY GPO /10 AMP DUO SWITCHERE SOCKET OUTLET, GILLET ST - REPLACE STOVE, UNIT 3, TOWN CLOCK - RECONNECT AND TEST TOWN CLOCK CHILD CARE - INSTALL GPO FOR RETICULATION/10 AMP WP DOUBLE SWITCHED SOCKET OUT /16 AMP RCD COMBO 4.5k	3465.44	
EFT14412	13/09/2024	GLOBAL WORKWEAR INVESTMENTS PTY LTD (TWW)	4 x PVC APRONS FOR POTHOLING - DEPOT	100.63	
EFT14413	13/09/2024	TARNYA FRASER	4 x NIGHTS ACCOMODATION FOR 5 x CONTRACTORS WORKING AT PARKER HOUSE	970.00	
EFT14414	13/09/2024	CEMETERIES & CREMATORIA ASSOCIATION OF WA	CEMETERIES & CREMATORIA ANNUAL MEMBERSHIP 2024/2025	130.00	
EFT14415	13/09/2024	PLUMBER'S MOBILE	DAYCARE - MINOR PLUMBING REPAIRS	88.00	
EFT14416	20/09/2024	QUAIRADING TYRE & BATTERY SUPPLIES	225/45R20 SAILUN ATREZZO 4x FOR 2022 HYUNDAI SANTA FE 255/65R17 DUNLOP AT EMED VEHICLE Q685 - 225/45R20 SAILUN ATREZZO 4x GARDENS CAR - REPAIR RV TYRE, 6MM MUSHY	1339.50	
EFT14417	20/09/2024	AVON WASTE	DOM RUBBISH X4 WEEKS, RECYCLING SERVICES, WASTE SERVICES FOR AUGUST 2024	10327.66	PARTIALLY
EFT14418	20/09/2024	LANDGATE	RURAL UV'S CHARGABLE - SCHEDULE: R2024/02 DATE: 20/07/24 TO 02/08/2024, SCHEDULE: R2024/03 DATE: 03/08/2024 TO 16/08/2024	235.90	

EFT14419	20/09/2024	COMMUNITY RESOURCE CENTRE -	AUGUST 2024 ADMINISTRATION COSTS PROVIDED BY CRC STAFF FOR PHOTOCOPYING, PRINTING & LAMINATING	497.76	
EFT14420	20/09/2024	CDA AIR CONDITIONING & REFRIGERATION	DIAGNOSE & REPAIR AIR CON NURSES ROOM QUAIRADING MEDICAL CENTRE	666.50	
EFT14421	20/09/2024	QUAIRADING TYRE & BATTERY - COMMUNITY CAR	FUEL FOR COMMUNITY CAR	51.00	FULLY
EFT14422	20/09/2024	STATE LIBRARY OF WA	2024/25 BETTER BEGINNINGS PROGRAM - WA STATE LIBRARY	44.00	
EFT14423	20/09/2024	WATER CORPORATION	WATER CONNECTION FEE - SOUTH CAROLING FIRE WATER TANK - STANDPIPES	2058.24	
EFT14424	20/09/2024	DEPARTMENT OF FIRE AND EMERGENCY SERVICES	2024/25 ESL QUARTER 1 IN ACCORDANCE WITH THE DEPARTMENT OF FIRE & EMERGENCY SERVICES	26030.70	FULLY
EFT14425	20/09/2024	LEONARD CUTFORTH	RELEASE OF PET BOND	200.00	FULLY
EFT14426	20/09/2024	GREAT SOUTHERN FUEL SUPPLIES	5000L OF DIESEL, WORKS DEPOT	8306.49	
EFT14427	20/09/2024	LOCAL GOVERNMENT SUPERVISORS ASSOCIATION	LOCAL GOVT WORKS ASSN CONFERENCE - PROFESSIONAL DEVELOPMENT-EMWS, SP&G	2035.00	
EFT14428	20/09/2024	QUEST INNALOO	5 NIGHTS ACCOMMODATION - FOR DEPARTMENT OF TRANSPORT AGENT TRAINING - CSFO 25/8/2024 - 29/8/2024	996.00	FULLY
EFT14429	20/09/2024	K2 AUDIOVISUAL PTY LTD	1- REPLACEMENT CONTROL PANEL, LESSER HALL, 2- ANNUAL AV SERVICE CONTRACTS - QUAIRADING SHIRE HALL	4037.00	
EFT14430	20/09/2024	Nutrien Ag Solutions	REPLACEMENT PUMP 50L SILVAN SPRAYER & HI FLOW 12V DIESEL TRANSFER KIT - DEPOT	2070.75	
EFT14431	20/09/2024	RESONLINE PTY LTD	ROOM MANAGER (CARAVAN PARK BOOKINGS) MONTHLY FEE - AUGUST 2024	242.00	

EFT14432	20/09/2024	QUAIRADING TYRE & BATTERY SUPPLIES - FUEL ACCOUNT	QGD TYRE & BATTERY FUEL ACCT - JULY 2024 FOR 2022 HYUNDAI SANTA FE, Q.0 & DEPOT C/PARK FUEL, YOUTH CENTRE FUEL (REEDY, NAIDOC Event), MOWER FUEL / DEPOT EQUIPMENT, 0Q FUEL x2 MOWERS F/DIESEL, JERRY CANS- F/ULP, JEN'S CAR-F/ULP, FORKLIFT-F/ULP, F/ULP - Q0	1441.01	
EFT14433	20/09/2024	NICOLE GIBBS	PARTIAL REFUND OF HOUSING BOND	89.82	FULLY
EFT14434	20/09/2024	SNALLOW PTY LTD T/A WALLIS COMPUTER SOLUTIONS	WALLIS COMPUTERS - ONGOING HOSTING, LICENSING & CALL COSTS, RENTAL OF HANDSETS ETC FOR THE PERIOD 1/07/24 - 30/06/25	9430.30	
EFT14435	20/09/2024	NEWGROUND WATER SERVICES	NEW PARK- 2 x 10 VALVE COVERS- IRRIGATION AT KWIRRADING KOORT	59.40	
EFT14436	20/09/2024	HUTTON & NORTHEY SALES	RUBBER CAP x 2 FOR 2018 ISUZU D-MAX SINGLE CAB UTE	41.36	
EFT14437	20/09/2024	ELDERS QUAIRADING	SUPPLIES FOR PARKS & GARDENS, DEPOT, 2018 ISUZU D-MAX & RECYCLE SERVICES - HOSE GREY-LINE, CAMLOCK NYGLASS, TRIDON CLAMP, INLET & OUTLET 50MM, GARDENMASTER WHAND WEEDER, CEMENT RAPIDSET, SUPERWASH CT18, KINCROME, ENERGISER BATTERY	1358.70	
EFT14438	20/09/2024	PORTER CONSULTING ENGINEERS	QUAIRADING LIA PHASE #2 - WAPC CLEARANCES	8266.28	
EFT14439	20/09/2024	CLEARSHIELD AUSTRALIA	74 MCLENNAN ST - REPLACEMENT FRONT ENTRY SCREEN DOOR	1430.00	
EFT14440	20/09/2024	AGRISOURCE AGENCIES	REFUND OF BUS BOND	150.00	FULLY
EFT14441	20/09/2024	READYTECH (PREVIOUSLY IT VISION)	READYTECH USER GROUP - MEMBERSHIP SUBSCRIPTION 2024/2025 DELETE INCORRECT BATCHES FOR PAYROLL, REBUILD GL, JOB LEDGER AND PLANT LEDGER REVERSE DISPOSAL OF PLANT IN SYNERGY REVERSAL OF DUPLICATE UNIVERSAL JOURNAL	2510.20	
EFT14442	20/09/2024	BOC LIMITED	CONTAINER SERVICE & DAILY TRACKING FOR THE PERIOD 29/07/24 - 28/08/24 R020E2 OXYGEN INDUSTRIAL E2 SIZE, R040G DISSOLVED ACENTYLENE G SIZE, R065G AGROSHIELD UNIVERSAL G SIZE, R400C OXYGEN MEDICAL C SIZE	50.97	
EFT14443	27/09/2024	QUAIRADING FARMERS CO-OP	QUAIRADING FARMERS COOP - JUNE ACCOUNT YOUTH/RAP MEETING, ADMIN CONSUMABLES, DEPOT CONSUMABLES, WRF CONSUMABLES & COUNCIL REFRESHMENTS	748.70	PARTIALLY

EFT14444	27/09/2024	TELSTRA	TELSTRA ACC#3147560712 SUPPLY AND USAGE FOR AUGUST - DEPOT MOBILES, SHIRE ADMIN TELSTRA ACC#3147560712 SUPPLY AND USAGE FOR 16/9/24-15/10/24 - DEPOT MOBILES, C/PARK MOBILE, CESM MOBILE, WRF MOBILE	927.79	
EFT14445	27/09/2024	QUAIRADING EARTHMOVING CO.	ROAD MAINTENANCE - DANGIN NTH RD, TOPIN RD, MINCHIN RD, BALKULING NTH RD & KEVILL RD	24337.50	PARTIALLY
EFT14446	27/09/2024	COUNTRY COPIERS	ADMIN COPIER METER READING FOR THE PERIOD 12/08/24 - 10/09/24	699.00	
EFT14447	27/09/2024	QUAIRADING CLUB INC.	REFRESHMENTS FOR COUNCIL MEETINGS	110.00	
EFT14448	27/09/2024	INSTANT WEIGHING	2016 CATERPILLAR LOADER - CALIBRATION NON TRADE SCALES - up to 10T	985.60	
EFT14449	27/09/2024	CONNELLY IMAGES - EFTSURE VERIFIED	PILOT GRAIN MAN FOR QTTT GROUP - AIR STRIP ENTRY	957.00	
EFT14450	27/09/2024	CDA AIR CONDITIONING & REFRIGERATION	SERVICE REVERSE CYCLE AIRCON. REATTACH RETURN AIR DUCT TO INDOOR UNIT, RETAPED DUCT TO LIVING ROOM AND TIGHTEN HANGERS OF DUCTWORK - 7 EDWARDS WAY	130.00	
EFT14451	27/09/2024	READYTECH USER GROUP (PREVIOUSLY IT VISION USER GROUP)	READYTECH USER GROUP WA - MEMBERSHIP FEES 2024/2025	847.00	
EFT14452	27/09/2024	A W DUNCAN CARPENTRY SERVICES	DOOR AND LOCK INSTALATION - VETRINARY CLINIC	2589.40	
EFT14453	27/09/2024	DOODENANNING SPORTING CLUB INC	REIMBURSEMENT OF BUSINESS LIABILITY AND BUILDING INSURANCE FOR DOODENANNING GOLF AND TENNIS CLUB WITHIN THE SHIRES ASSEST DOODENANNING HALL 2024/25	1166.00	

EFT14454	27/09/2024	BOB WADDELL & ASSOCIATES PTY LTD	ASSISTANCE WITH THE 2023/2024 ANNUAL FINANCIAL REPORT INCL WORK DONE ON EOY ASSETS 2024/225 RATES MANAGEMENT: 6.5HRS SERVICE PROVIDED BY TARA (W/E: 31/08/24) PENSIONER CLAIMS, APPLICATIONS & LETTERS, INTRIM SCHEDULES, PRE BILLING PREPARATION 2024/225 RATES MANAGEMENT: 9HRS SERVICE PROVIDED BY TARA (W/E: 08/09/24) PENSIONER CLAIMS,INTRIM SCHEDULES, ADJUSTMENTS & RATES BILLING	7304.00	
EFT14455	27/09/2024	SYNERGY	SYNERGY ACC#558474190 SUPPLY & USAGE FOR THE PERIOD 11/7/24-9/9/24 - 13941 KWH USED (AKV GENERAL), UNITS 1 - 8 & PARKER HOUSE SYNERGY ACC#857387870 SUPPLY & USAGE FOR THE PERIOD 25/7/24 - 24/8/24 - 156 STREETLIGHTS - OVERDUE PAYMENT FEE SYNERGY ACC#831204500 SUPPLY & USAGE FOR THE PERIOD 11/7/24-6/9/24 - 188 KWH USED (STREET LIGHTS) SYNERGY ACC#404791220 SUPPLY & USAGE FOR THE PERIOD 10/7/24-5/9/24 - 2329.3290 KWH USED (64 CORALING STREET) SYNERGY ACC#893699340 SUPPLY & USAGE FOR THE PERIOD 11/07/24-10/9/24 - 2894 KWH USED (SHIRE ADMIN) SYNERGY ACC#187804760 SUPPLY & USAGE FOR THE PERIOD 10/7/24-5/9/24 - 48.94 KWH USED (Q WRF) SYNERGY ACC#544185110 SUPPLY & USAGE FOR THE PERIOD 11/7/24-6/9/24 - 689 KWH USED (Q RAILWAY) SYNERGY ACC#137709150 SUPPLY & USAGE FOR THE PERIOD 11/7/24-9/9/24 - 4359.1070 KWH USED (DRS RESIDENCE & QMP) SYNERGY ACC#689509470 SUPPLY & USAGE FOR THE PERIOD 11/7/24-6/9/24 - 4372.06 KWH USED (LOT 190 MCLENNAN & OVAL AND GROUNDS) SYNERGY ACC#422437350 SUPPLY & USAGE FOR THE PERIOD 12/7/24-10/9/24 - 1254 KWH USED (UA 50 SUBURBAN ROAD) SYNERGY ACC#422743450 SUPPLY & USAGE FOR THE PERIOD 12/7/24-10/9/24 - 60 KWH USED (31 DALL STREET) SYNERGY ACC#389453150 SUPPLY & USAGE FOR THE PERIOD 12/7/24-10/9/24 - 1699 KWH USED (8 DALL STREET) SYNERGY ACC#137839080 SUPPLY & USAGE FOR THE PERIOD 14/8/24-10/9/24 - 651.01120 KWH USED (Q CRC) SYNERGY ACC#298130670 SUPPLY & USAGE FOR THE PERIOD 11/7/24-6/9/24 - 2019.98 KWH USED (SHIRE DEPOT)	21130.40	PARTIALLY

			<p>SYNERGY ACC#885514750 SUPPLY & USAGE FOR THE PERIOD 10/7/24-5/9/24 - 4955.2370 KWH USED 19 GILLETT STREET UNITS 1 - 4 & COMMON AREA</p> <p>SYNERGY ACC#765171390 SUPPLY AND USAGE FOR THE PERIOD 8/8/24-11/9/24 - C/PARK CARETAKER RESIDENCE,SYNERGY ACC#765171390 SUPPLY AND USAGE FOR THE PERIOD 8/8/24-11/9/24 - C/PARK CARETAKER RESIDENCE, CABINS 1-7 & PARKS AND GARDENS</p> <p>SYNERGY ACC#765171390 SUPPLY AND USAGE FOR THE PERIOD 8/8/24-11/9/24 - SWIMMING POOL</p> <p>SYNERGY ACC#765171390 SUPPLY AND USAGE FOR THE PERIOD 8/8/24-11/9/24 - CARAVAN PARK PUBLIC AREAS</p> <p>SYNERGY ACC#438321960 SUPPLY & USAGE FOR THE PERIOD 2/8/24-10/9/24 - 601 KWH USED (74 MCLENNAN STREET)</p> <p>SYNERGY ACC#207862210 SUPPLY & USAGE FOR THE PERIOD 10/7/24 - 5/9/24 - 726.15 KWH USED (YOUTH CENTRE) - OVERDUE PAYMENT FEE</p> <p>SYNERGY ACC#431870690 SUPPLY & USAGE FOR THE PERIOD 12/7/24-10/9/24 - 805 KWH USED (50B SUBURBAN)</p> <p>SYNERGY ACC#222214330 SUPPLY & USAGE FOR THE PERIOD 11/7/24-9/9/24 - 434 KWH USED (REED CHILDCARE)</p> <p>SYNERGY ACC#831204500 SUPPLY & USAGE FOR THE PERIOD 11/7/24-6/9/24 - 188 KWH USED (STREET LIGHTS)</p> <p>SYNERGY ACC#408945020 SUPPLY & USAGE FOR THE PERIOD 11/7/24-9/9/24 - 512 KWH USED (OTH BORES)</p> <p>SYNERGY ACC#936409630 SUPPLY & USAGE FOR THE PERIOD 11/7/24-9/9/24 - 157 KWH USED (OTH BORES)</p> <p>SYNERGY ACC#704417150 SUPPLY & USAGE FOR THE PERIOD 11/7/24-9/9/24 - 131 KWH USED (Q AIRSTRIP)</p>		
EFT14456	27/09/2024	SULLIVAN LOGISTICS PTY LTD T/A KALEXPRESS AND QUALITY TRANSPORT	FREIGHT , TEST & TAG MACHINE TO ZEDFLOW	35.07	
EFT14457	27/09/2024	JENNIFER GREEN	REIMBURSEMENT FOR COMMUNITY PERCEPTION SURVEY FLYERS	74.98	
EFT14458	27/09/2024	WA LOCAL GOVERNMENT ASSOCIATION	WALGA MEMBERSHIPS AND SUBSCRIPTIONS FOR 2024/25 WALGA LOCAL GOVERNMENT CONVENTION ATTENDANCE CEO, SHIRE PRESIDENT, DEPUTY SHIRE PRESIDENT & 2 COUNCILLORS	25932.61	

EFT14459	27/09/2024	COMBINED PEST CONTROL	DAYCARE-SPOT TERMITE TREATMENT	110.00	
EFT14460	27/09/2024	WA CONTRACT RANGER SERVICES PTY LTD	CONTRACT RANGER SERVICES FOR THE MONTH OF AUGUST 2024 - DATES SERVICED 27/08, 28/08 & 29/08 2024 CONTRACT RANGER SERVICES FOR THE MONTH OF SEPTEMBER 2024 - DATES SERVICED 05/09/24	1155.00	
EFT14461	27/09/2024	C & D CUTRI	BRIDGE REPAIRS, 4145 BADJALING NTH RD & BRIDGE 4149 GEYER ST, DOODENANNING - R2R FUNDING	25630.00	PARTIALLY
EFT14462	27/09/2024	NORTHAM MAZDA	2024 BT50 UTE (TO REPLACE Q661- TRITON) SUPERVISOR GROUNDS & GARDENS	56850.50	
EFT14463	27/09/2024	LOCAL GOVERNMENT PROFESSIONALS	PROJECT MGMT ESSENTIALS TRAINING - SEPT 2024 (WORKS DEPOT STAFF) OCT 2024 (CPARK MGR) 2024 - 2025 FULL MEMEBERSHIP TO LG PROFESSIONALS - CEO, EMED	2420.00	
EFT14464	27/09/2024	NORTHAM AUTOS PTY LTD	DASH MAT - BT50 - WORKS SUPERVISOR VEHICLE	94.73	
EFT14465	27/09/2024	QUAIRADING BOOK POST (2020)	MONTHLY PROVISION OF LIBRARY SERVICES - AUGUST 2024 ADMIN POSTAGE & STATIONERY - AUGUST 2024	2497.18	
EFT14466	27/09/2024	BRIAN KIMBER	SKELETON WEED REIMBURSEMENT - COMMUNICATIONS: TELEPHONE CHARGES 15.08.24 - 14.09.24, SKELETON WEED REIMBURSEMENT - VEHICLE COSTS: FUEL PURCHASES, SKELETON WEED REIMBURSEMENT - OTHER EXPENDITURE: UNIQUEFIX U-TEC MOBILE REPAIR SERVICES, SKELETON WEED REIMBURSEMENT - OTHER EXPENDITURE: UNIQUEFIX U-TEC SCREEN PROTECTOR	531.12	FULLY
EFT14467	27/09/2024	FARMARAMA PTY LTD	DOUBLE KENNEL - ANIMAL CONTROL - POUND, INCL FREIGHT TO QDG	1949.00	
EFT14468	27/09/2024	Crisp Wireless	ATTEND WASTE SITE AND MOUNT OUTDOOR UNIT FOR WRF WIFI NETWORK EXTENSION	275.00	
EFT14469	27/09/2024	ALTUS PLANNING - EFTSURE VERIFIED	TOWN PLANNING SERVICES FOR AUGUST 2024	2116.13	
EFT14470	27/09/2024	AGRIBATE CONTRACTING	AVON SOUTH LOCAL ACTION GROUP - SKELETON WEED PROGRAMME 2024	1523.28	FULLY
EFT14471	27/09/2024	HALL BROS CONTRACTING (STEPHEN SMITH HALL)	REPAIRS TO 2016 CAT LOADER 938K2	195.00	

EFT14472	27/09/2024	GARRETT'S GARAGE	Q458 - 83,000km SERVICE COMMUNITY BUS	823.38	
EFT14473	27/09/2024	VERIZON CONNECT	VEHICLE TRACKER- MONTHLY SUBSCRIPTION SEPT 2024	496.10	
EFT14474	27/09/2024	A DAWSON & P.S DAWSON (SANDY) - VERIFIED	50M2 OF FOOTPATH - ALONG MACDONALD ST TO REAR OF MEDICAL PRACTICE	6050.00	
EFT14475	27/09/2024	SOFTSCAPES & RETICULATION PTY LTD -	LANDSCAPING FOR PARKER HOUSE PROJECT (INCL - PREP WORK, RETICULATION, STEEL EDGING, PLANTS, PEA GRAVEL, ROCKS, PAVING & MULCH)	21684.00	
EFT14476	27/09/2024	Process Control Instrumentation Pty Ltd T/As Zedflo Australia - EFTSURE VERIFIED	CALIBRATION OF METRAL TEST AND TAG MACHINE - DEPOT	236.50	
EFT14477	27/09/2024	JARVIS YARRAN	REFUND OF BOOKING #1325239 - CHECK IN 02.09.24 CHECK OUT 22.09.24	257.10	FULLY
EFT14478	27/09/2024	ELDERS INSURANCE - MOTOR CLAIMS	EXCESS OF VEHICLE INSURANCE CLAIM EK0111016 - SKELETON WEED VEHICLE	700.00	
				\$ 878,517.90	

TRANSPORT TAKINGS FOR THE MONTH ENDING
30 SEPTEMBER 2024 **Attachment 11.1 (ii)**

ACTUAL TOTAL TAKINGS		
DATE OF TAKINGS	DESCRIPTION	AMOUNT \$
29/08/2024	TRANSPORT TAKINGS	\$175.70
30/08/2024	TRANSPORT TAKINGS	\$3,780.25
2/09/2024	TRANSPORT TAKINGS	\$6,012.20
3/09/2024	TRANSPORT TAKINGS	\$774.00
4/09/2024	TRANSPORT TAKINGS	\$1,356.45
6/09/2024	TRANSPORT TAKINGS	\$3,076.55
09/09/202	TRANSPORT TAKINGS	\$3,364.45
10/09/2024	TRANSPORT TAKINGS	\$3,507.20
11/09/2024	TRANSPORT TAKINGS	\$4,008.25
12/09/2024	TRANSPORT TAKINGS	\$2,292.10
13/09/2024	TRANSPORT TAKINGS	\$1,916.30
16/09/2024	TRANSPORT TAKINGS	\$361.00
17/09/2024	TRANSPORT TAKINGS	\$856.00
18/09/2024	TRANSPORT TAKINGS	\$504.25
19/09/2024	TRANSPORT TAKINGS	\$6,398.55
24/09/2024	TRANSPORT TAKINGS	\$1,511.15
25/09/2024	TRANSPORT TAKINGS	\$1,265.50
26/09/2024	TRANSPORT TAKINGS	\$1,619.30
TAKINGS RECEIVED IN THE BANK - SEPTEMBER 2024		\$42,779.20

AMOUNTS YET TO BE DRAWN		
DATE OF TAKINGS	DESCRIPTION	AMOUNT \$
27/09/2024	TRANSPORT TAKINGS	\$1,458.75
30/06/2024	TRANSPORT TAKINGS	\$764.30
SEPTEMBER TAKINGS RECEIVED IN THE BANK - OCTOBER 2024		\$2,223.05

Shire of Quairading
Credit Card Reconciliation - Page 1

Statement From 28/08/2024 Statement Total
Statement To 29/09/2024 \$ 7,991.69



Credit Card Summary		
Card Name	Title	Card Ending
Natalie Ness	CEO	\$ 2,258.64
Tricia Brown	EMCS	\$ 469.95
Benjamin Davies	CESM	\$ 1,272.40
Sarah Caporn	EMWS	\$ 3,990.70

Credit Card Transaction - GL Entry			
GL Code	Amount (incl GST)	GST (\$)	Narration/Summary
121402040.2003	\$ 214.50	\$ 19.50	CONFERENCE - LOCAL GOVERNMENT GUIDANCE FOR EO
POQ1.2610.4001	\$ 137.45	\$ 12.50	FUEL FOR POQ1
121402040.2100	\$ 99.00	\$ 9.00	POLICE CHECK FOR SFO
POQ1.2410.2704	\$ 19.00	\$ 1.73	CAR WASH FOR POQ1
2050287.2101'	\$ 19.00	\$ 1.73	CONTAINER FOR DOG FOOD - DEPOT POUND
121403040.2100	\$ 545.70	\$ 49.61	ACCOMMODATION FOR WORKS SUPERVISOR & TLG&G - PROJECT MANAGEMENT TRAINING
BO10102.2101	\$ 755.00	\$ 68.64	SAFETY BOOKS FOR WORK EXPERIENCE STUDENT & 6 CARTONS GREEN ONION BAGS FOR WRF
BM13811.2101	\$ 150.00	\$ 13.64	BIND SPIKES FOR SPORTS GROUND
P432.2400.2101'	\$ 200.00	\$ -	NUMBER PLATE ORDER FOR SPORTSGROUND MOWER - 432Q
12140304.2910	\$ 44.00	\$ -	RENEWAL OF FORK LIFT LICENSE - DEPOT GENERAL HAND
1240304.2910	\$ 206.31	\$ 18.76	MEAL ALLOWANCE FOR DEPOT SUPERVISORS LEADERSHIP TRAINING - STAT DEC
W11300.2101	\$ 211.20	\$ 19.20	DEPOT - GARDEN TOOLS (RAKE, SHOVELS)
12140330.2101	\$ 1,808.99	\$ 164.46	DRUG TEST KITS
P190.2400.2101	\$ 31.10	\$ -	CHANGE OF NUMBER PLATE PRIOR TO ASSET DISPOSAL
9661.2400.2101	\$ 19.40	\$ -	CHANGE OF PLATE NUMBER PLATE ON NEW ASSET
PROU002.2610.2101	\$ 541.51	\$ 49.23	CESM vehicle fuel
PROU002.2600.2101	\$ 52.39	\$ 5.43	CESM VEHICLE STORAGE MATERIALS
2050765.2104	\$ 165.00	\$ 15.00	BART ALERT SUBSCRIPTION (EMERGENCY RESPONSE APP)
2050164.2101	\$ 361.28	\$ 32.85	QUAIRADING BFB STATION MATERIALS/SUPPLIES
2050765.2100	\$ 152.22	\$ 0.80	BFB AGM BBQ - QUAIRADING QUAIRADING BRB TRAINING REFRESHMENTS BFB AGM BBQ - TAMMIN (TO BE ONCHARGED)
121402040.2003	\$ 98.84	\$ 8.99	REFRESHMENTS FOR CSFO DOT TRAINING
2130642.2101	\$ 151.05	\$ 13.74	PROJECT SETTLEMENT MEETING REFRESHMENTS GROH HOUSING PROJECT MEETING REFRESHMENTS MY HOME HOUSING PROJECT MEETING REFRESHMENTS
PQ0.2610.4001	\$ 170.02	\$ 15.47	FUEL FOR Q.O
PQ0.2410.2704	\$ 19.98	\$ 1.82	QO CASH WASH
2040211.2101'	\$ 205.95	\$ 18.72	QUAIRADING SPORTS PRECINCT PROJECT - WELCOME TO COUNTRY
BO13811.2970.2101	\$ 1,612.80	\$ 146.62	REPLACEMENT OF WINDSCREEN FOR L.WINMAR DUE TO DAMAGE CAUSED BY DEPOT GARDENS CREW.
Totals	\$ 7,991.69	\$ 687.44	ACCOUNTS PROCESSING

Shire Confirmation

 Natalie Ness, Chief Executive Officer

Council Approval

 Trevor Stacey, Chair A&R Committee

Journal Date (DD):
 Journal Number:
 Journal Batch:
 Journal Posting Period:



Electronic Statement

BusinessChoice Everyday Mastercard® Statement

Billing Account Number

 Payment Due Date

 Closing Balance

 Minimum Payment Due

 Amount Paid (Details on the reverse)
 \$

+5163280091099937+

(Cut along this dotted line)

For enquiries please call 1300 650 107 (8am - 8pm, Monday to Friday). Lost or stolen cards service available 24 hours a day, 7 days a week.

Any statement entries for purchases or cash advances made in a foreign currency show the foreign currency transaction amount converted into Australian dollars by the applicable credit card scheme. Any applicable Westpac Foreign Transaction Fee (described below as "Foreign Transaction Fee") charged is shown as a separate entry.

Company Name	Number of Cards	Facility Number	Annual Cash % Rate	Annual Purchase % Rate		
Shire Of Quairading	4	02752751	19.96%	14.25%		
Contact Name	Billing Account Number	Opening Balance	Credit Limit			
Natalie Ness	5163280091099937	9,388.52	20,000			
Statement From	Statement To	Payment Due Date	Opening Balance	Minimum Payment Due	Closing Balance	Available Credit
28 AUG 2024	29 SEP 2024	24 OCT 2024	9,388.52	240.00	7,991.69	12,008.31

Summary of Changes in Your Account Since Last Statement

From Your Opening Balance of	We Deducted Payments and Other Credits	And We Added				To Arrive at Your Closing Balance of	Total Past Due / Overlimit balances	Your minimum payment including past due overlimit is
		New purchases	Cash advances	Fees, Interest & Government Charges	Miscellaneous Transactions			
9,388.52	9,388.52 -	0.00	0.00	0.00	7,991.69	7,991.69	0.00	240.00

Electronic Statement



Important:

1. If mailing DO NOT send notes or coins.
2. Please write your Payment Account Number on the back of each cheque.
3. Check your records of your transactions against this statement.
4. Report any discrepancies to Westpac.

Details of cheques (proceeds may not be available until cleared)

				CASH AMOUNT
DRAWER (i.e. account name on cheque)	CHEQUE NO.	BSB NO. OR BANK	ACCOUNT NO. OR BRANCH	CHEQUE AMOUNT
TELLER/BANK STAMP			TOTAL \$	
SIGNATURE: _____				



Choose the payment method that suits you best



By Mail

Complete and mail the top portion of page one of your statement together with your cheque to: Cards GPO Box 4220 Sydney NSW 2001



Using Card Autopay

Pay your account automatically from any cheque or non-passbook savings account with any bank or financial institution in Australia. To apply for Card Autopay for your credit card, call 1300 651 089 or download a form online at www.westpac.com.au.



By Telephone Banking

Call 132 032 if you have another Westpac account.



Via Westpac Internet Banking

At www.westpac.com.au if you have another Westpac account.

Using BPAY

Contact any participating institution to make this payment from your cheque or savings account.



When prompted, simply enter the biller code (5181) and your Payment Account Number as your reference number.



In Person

At any of our Westpac branches in Australia.

Important notice regarding Autopay Direct Debit Arrangement- Direct Debit

* If you have set up a direct debit arrangement for making automatic repayments to your BusinessChoice credit card account, and there have been two failed direct debit transactions (that is, we cannot withdraw the nominated amount from your nominated account) in consecutive months due to insufficient funds in the nominated account, we may, at our sole discretion:

1. Cancel your BusinessChoice Facility Autopay Request Form- Direct Debit Request (New change)
2. Impose a fee or charge (No change- We currently charge a \$15 missed payment fee when payment is not received by statement due date)
3. Charge interest on any unpaid purchases outstanding (No change)

If your Direct Debit Request is cancelled, you must arrange to either set up a new Autopay Request Form- Direct Debit Request or use alternative payment methods so we can process your payment. Please ensure that there are sufficient funds available in the nominated account to allow direct debit payments to be made in accordance with your BusinessChoice Facility Autopay Request Form- Direct Debit Request.

Please remember any payments made into the Billing account that places the Billing Account into credit or results in a zero balance at the payment due date, your direct debit will still continue to take place. This also applies if you make an additional payment into the Billing Account that is only a partial payment and still leaves a debit balance on the Billing Account, your direct debit arrangement for the month will remain unchanged and continue to take place.



Electronic Statement

Summary of Billing Account Transactions		
Date of Transaction	Description	Debits/Credits
11 SEP	Payments AUTOMATIC PAYMENT	9,388.52 -
	Sub Total:	9,388.52 -
	Miscellaneous Transactions	
29 SEP	NATALIE NESS 5163 2800 0106 6463 Monthly Balance	2,258.64
29 SEP	TRICIA BROWN 5163 2800 0107 6777 Monthly Balance	469.95
29 SEP	SARAH CAPORN 5163 2800 0153 8917 Monthly Balance	3,990.70
29 SEP	BENJAMIN DAVIES 5163 2800 0197 3585 Monthly Balance	1,272.40
	Sub Total:	7,991.69
	Grand Total:	1,396.83 -

Remember to always keep your passcode secret - don't tell anyone or let them see it. Never write your passcode on your card or on anything that could be lost or stolen. If you do need to record a reminder, you must make every effort to disguise it. You may be liable for losses if you don't protect your passcode.

To help you learn how you can protect your card against unauthorised transactions, you can find more information at westpac.com.au/businessdispute

Important update to your Terms and Conditions

We're updating the Westpac BusinessChoice Cards Terms and Conditions, with effect from 13 December 2022. The update includes additional wording to confirm that a nominated cardholder is authorised to request a replacement card on behalf of the liable party (or parties) where the cardholder's existing card is lost, damaged or stolen, except where the card has been cancelled by the liable party (or parties). Please read these updated Terms and Conditions available at westpac.com.au

Complaints

If you have a complaint, contact our dedicated Customer Solutions team on 132 032 or write to us at Westpac Customer Solutions, Reply Paid 5265, Sydney NSW 2001. If an issue has not been resolved to your satisfaction, you can lodge a complaint with the Australian Financial Complaints Authority (AFCA). AFCA provides fair and independent financial services complaint resolution that is free to consumers.

Online: www.afca.org.au

Email: info@afca.org.au

Phone 1800 931 678

Mail: Australian Financial Complaints Authority GPO Box 3 Melbourne VIC 3001

Credit Card Reconciliation - Page 2						
	Statement From	28/08/2024				
	Statement To	29/09/2024				
** Denotes an error. These are to be refunded.						
Credit Card Transactions - Natalie Ness, CEO						
Transaction Date	Statement Description	Amount (incl GST)	GST (\$)	GST (Y/N)	GL/Job	Narration
27/08/2024	Sushi WaWa	\$ 42.30	\$ 3.85	Y	121402040.2003	REFRESHMENTS - CSFO DOT TRAINING
28/08/2024	Sushi WaWa	\$ 11.74	\$ 1.07	Y	121402040.2003	REFRESHMENTS - CSFO DOT TRAINING
27/08/2024	Tassels Place	\$ 5.50	\$ 0.50	Y	121402040.2003	REFRESHMENTS - CSFO DOT TRAINING
28/08/2024	Tassels Place	\$ 5.50	\$ 0.50	Y	121402040.2003	REFRESHMENTS - CSFO DOT TRAINING
29/08/2024	Tassels Place	\$ 5.50	\$ 0.50	Y	121402040.2003	REFRESHMENTS - CSFO DOT TRAINING
29/08/2024	Grilld	\$ 22.80	\$ 2.07	Y	121402040.2003	REFRESHMENTS - CSFO DOT TRAINING
30/08/2024	Tassels Place	\$ 5.50	\$ 0.50	Y	121402040.2003	REFRESHMENTS - CSFO DOT TRAINING
31/08/2024	Ampol MUNDARING	\$ 60.01	\$ 5.46	Y	PQ0.2610.4001	FUEL FOR Q.0
5/09/2024	Golden Grain Café	\$ 19.00	\$ 1.73	Y	2130642.2101'	REFRESHMENTS GROH HOUSING PROJECT
6/09/2024	Golden Grain Café	\$ 13.00	\$ 1.18	Y	2130642.2101'	REFRESHMENTS - MY HOUSING PROJECT
10/09/2024	Quairading LPO	\$ 205.95	\$ 18.72	Y	2040211.2101'	QUAIRADING SPORTS PRECINCT PROJECT - WELCOME TO COUNTRY
12/09/2024	Dome NORTHAM	\$ 28.35	\$ 2.58	Y	2130642.2101'	REFRESHMENTS - PROJECT SETTLEMENT MEETING
13/09/2024	Quairading BP	\$ 90.70	\$ 8.25	Y	2130642.2101'	SHIRE ADMIN - STAFF LUNCH
19/09/2024	Canning Bridge Nedlands (Car wash)	\$ 19.98	\$ 1.82	Y	PQ0.2410.2704	QO CASH WASH
19/09/2024	Coles express KARAWARA	\$ 50.00	\$ 4.55	Y	PQ0.2610.4001	FUEL FOR Q.0
24/09/2024	Coles express NORTHAM	\$ 60.01	\$ 5.46	Y	PQ0.2610.4001	FUEL FOR Q.0
25/09/2024	INSTAND WINDOW SCREENS MYAREE	\$ 1,612.80	\$ 146.62	Y	BO13811.2970.2101	REPLACEMENT OF WINDSCREEN FOR L.WINMAR DUE TO DAMAGE CAUSED BY DEPOT GARDENS CREW.
Total		\$ 2,258.64	\$ 205.33			



Electronic Statement

BusinessChoice Everyday Mastercard® Statement

For enquiries please call 1300 650 107 (8am - 8pm, Monday to Friday). Lost or stolen cards service available 24 hours a day, 7 days a week.

Any statement entries for purchases or cash advances made in a foreign currency show the foreign currency transaction amount converted into Australian dollars by the applicable credit card scheme. Any applicable Westpac Foreign Transaction Fee (described below as "Foreign Transaction Fee") charged is shown as a separate entry.

Card Account Transaction Details

Account Name	Card Number	Credit Limit	Available Credit
Natalie Jane Ness	5163 2800 0106 6463	5,000	5,000.00
Statement From	Statement To	Facility Number	
28 AUG 2024	29 SEP 2024	02752751	

Summary of Changes in Your Account Since Last Statement

From Your Opening Balance of	We Deducted Payments and Other Credits	And We Added				To Arrive at Your Closing Balance of	Total Past Due / Overlimit balances	Your minimum payment including past due overlimit is
		New purchases	Cash advances	Fees, Interest & Government Charges	Miscellaneous Transactions			
0.00	0.00	2,258.64	0.00	0.00	2,258.64 -	0.00	0.00	0.00

Electronic Statement



Important notice regarding Autopay Direct Debit Arrangement- Direct Debit

* If you have set up a direct debit arrangement for making automatic repayments to your BusinessChoice credit card account, and there have been two failed direct debit transactions (that is, we cannot withdraw the nominated amount from your nominated account) in consecutive months due to insufficient funds in the nominated account, we may, at our sole discretion:

1. Cancel your BusinessChoice Facility Autopay Request Form- Direct Debit Request (New change)
2. Impose a fee or charge (No change- We currently charge a \$15 missed payment fee when payment is not received by statement due date)
3. Charge interest on any unpaid purchases outstanding (No change)

If your Direct Debit Request is cancelled, you must arrange to either set up a new Autopay Request Form- Direct Debit Request or use alternative payment methods so we can process your payment.

Please ensure that there are sufficient funds available in the nominated account to allow direct debit payments to be made in accordance with your BusinessChoice Facility Autopay Request Form- Direct Debit Request.

Please remember any payments made into the Billing account that places the Billing Account into credit or results in a zero balance at the payment due date, your direct debit will still continue to take place. This also applies if you make an additional payment into the Billing Account that is only a partial payment and still leaves a debit balance on the Billing Account, your direct debit arrangement for the month will remain unchanged and continue to take place.

BusinessChoice Everyday Mastercard®			
Date of Transaction	Description	Debits/Credits	Cardholder Comments
	Purchases		
27 AUG	Sushi WaWa Innaloo AUS	42.30	
	EATING PLACES, RESTAURANTS		
28 AUG	Sushi WaWa Innaloo AUS	11.74	
	EATING PLACES, RESTAURANTS		
27 AUG	TASSELS PLACE INNALOO AUS	5.50	
	EATING PLACES, RESTAURANTS		
28 AUG	TASSELS PLACE INNALOO AUS	5.50	
	EATING PLACES, RESTAURANTS		
29 AUG	TASSELS PLACE INNALOO AUS	5.50	
	EATING PLACES, RESTAURANTS		
29 AUG	GRILLD INNALOO AUS	22.80	
	EATING PLACES, RESTAURANTS		
30 AUG	TASSELS PLACE INNALOO AUS	5.50	
	EATING PLACES, RESTAURANTS		
31 AUG	AMPOL MUNDARING 55498F MUNDARING SERVICE STATIONS AUS	60.01	
05 SEP	SQ *GOLDEN GRAIN CAFE/ Quairading MISCELLANEOUS FOOD STORES - AUS	19.00	
06 SEP	SQ *GOLDEN GRAIN CAFE/ Quairading MISCELLANEOUS FOOD STORES - AUS	13.00	
10 SEP	POST QUAIRADING LPO QUAIRADING POSTAL SERVICES GOVERNMENT O AUS	205.95	
12 SEP	DOVE NORTHAM NORTHAM EATING PLACES, RESTAURANTS AUS	28.35	
13 SEP	BP QUAIRADING 6561 QUAIRADING SERVICE STATIONS AUS	90.70	
19 SEP	CANNING BRIDGE SUPERWA Nedlands CAR WASHES AUS	19.98	
19 SEP	COLES EXPRESS 6929COLE KARAWARA SERVICE STATIONS AUS	50.00	

Electronic Statement



BusinessChoice Everyday Mastercard®			
Date of Transaction	Description	Debits/Credits	Cardholder Comments
24 SEP	COLES EXPRESS 2128COLE NORTHAM SERVICE STATIONS	AUS 60.01	
25 SEP	INSTANT WINDSCREENS MYAREE AUTOMOTIVE PARTS, ACCESSORIE	AUS 1,612.80	
	Sub Total:	2,258.64	
	Miscellaneous Transactions		
29 SEP	TRANSFER CLOSING BALANCE TO BILLING ACCT	2,258.64 -	
	Sub Total:	2,258.64 -	
	Grand Total:	0.00	

I have checked the above details and verify that they are correct.

Cardholder Signature *Walter Jess* Date 10/10/24

Transactions examined and approved.

Manager/Supervisor Signature *J. Sims* Date 24/10/24

Remember to always keep your passcode secret - don't tell anyone or let them see it. Never write your passcode on your card or on anything that could be lost or stolen. If you do need to record a reminder, you must make every effort to disguise it. You may be liable for losses if you don't protect your passcode.

To help you learn how you can protect your card against unauthorised transactions, you can find more information at westpac.com.au/businessdispute

Important update to your Terms and Conditions

We're updating the Westpac BusinessChoice Cards Terms and Conditions, with effect from 13 December 2022. The update includes additional wording to confirm that a nominated cardholder is authorised to request a replacement card on behalf of the liable party (or parties) where the cardholder's existing card is lost, damaged or stolen, except where the card has been cancelled by the liable party (or parties). Please read these updated Terms and Conditions available at westpac.com.au

Complaints

If you have a complaint, contact our dedicated Customer Solutions team on 132 032 or write to us at Westpac Customer Solutions, Reply Paid 5265, Sydney NSW 2001. If an issue has not been resolved to your satisfaction, you can lodge a complaint with the Australian Financial Complaints Authority (AFCA). AFCA provides fair and independent financial services complaint resolution that is free to consumers.

Online: www.afca.org.au

Email: info@afca.org.au

Phone 1800 931 678

Mail: Australian Financial Complaints Authority GPO Box 3 Melbourne VIC 3001

Shire of Quairading
Credit Card Reconciliation - Page 3

Statement From 28/08/2024
Statement To 29/09/2024

Credit Card Transactions - Tricia Brown, EMCS						
Transaction Date	Statement Description	Amount (incl GST)	GST (\$)	GST (Y/N)	GL/Job	Narration
30/08/2024	Moray Ticket BELROSE	\$ 214.50	\$ 19.50	y	121402040.2003	CONFERENCE - LOCAL GOVERNMENT GUIDANCE FOR EO
1/09/2024	Ampol DAWESVILLE	\$ 78.10	\$ 7.10	y	POQ1.2610.4001	FUEL FOR POQ1
8/09/2024	Ampol DAWESVILLE	\$ 59.35	\$ 5.40	Y	POQ1.2610.4001	FUEL FOR POQ1
13/09/2024	CRIMECHECK AUS	\$ 99.00	\$ 9.00	Y	121402040.2100	POLICE CHECK FOR SFO
24/09/2024	AQUA VALET CAR WASH	\$ 19.00	\$ 1.73	Y	POQ1.2410.2704	CAR WASH FOR POQ1
Total		\$ 469.95	\$ 42.72			



Electronic Statement

BusinessChoice Everyday Mastercard® Statement

For enquiries please call 1300 650 107 (8am - 8pm, Monday to Friday). Lost or stolen cards service available 24 hours a day, 7 days a week.

Any statement entries for purchases or cash advances made in a foreign currency show the foreign currency transaction amount converted into Australian dollars by the applicable credit card scheme. Any applicable Westpac Foreign Transaction Fee (described below as "Foreign Transaction Fee") charged is shown as a separate entry.

Card Account Transaction Details

Account Name	Card Number	Credit Limit	Available Credit
Tricia Brown	5163 2800 0107 6777	2,000	2,000.00
Statement From	Statement To	Facility Number	
28 AUG 2024	29 SEP 2024	02752751	

Summary of Changes in Your Account Since Last Statement

From Your Opening Balance of	We Deducted Payments and Other Credits	And We Added				To Arrive at Your Closing Balance of	Total Past Due / Overlimit balances	Your minimum payment including past due overlimit is
		New purchases	Cash advances	Fees, Interest & Government Charges	Miscellaneous Transactions			
0.00	0.00	469.95	0.00	0.00	469.95 -	0.00	0.00	0.00

Electronic Statement



Important notice regarding Autopay Direct Debit Arrangement- Direct Debit

* If you have set up a direct debit arrangement for making automatic repayments to your BusinessChoice credit card account, and there have been two failed direct debit transactions (that is, we cannot withdraw the nominated amount from your nominated account) in consecutive months due to insufficient funds in the nominated account, we may, at our sole discretion:

1. Cancel your BusinessChoice Facility Autopay Request Form- Direct Debit Request (New change)
2. Impose a fee or charge (No change- We currently charge a \$15 missed payment fee when payment is not received by statement due date)
3. Charge interest on any unpaid purchases outstanding (No change)

If your Direct Debit Request is cancelled, you must arrange to either set up a new Autopay Request Form- Direct Debit Request or use alternative payment methods so we can process your payment. Please ensure that there are sufficient funds available in the nominated account to allow direct debit payments to be made in accordance with your BusinessChoice Facility Autopay Request Form- Direct Debit Request.

Please remember any payments made into the Billing account that places the Billing Account into credit or results in a zero balance at the payment due date, your direct debit will still continue to take place. This also applies if you make an additional payment into the Billing Account that is only a partial payment and still leaves a debit balance on the Billing Account, your direct debit arrangement for the month will remain unchanged and continue to take place.

BusinessChoice Everyday Mastercard®			
Date of Transaction	Description	Debits/Credits	Cardholder Comments
	Purchases		
30 AUG	Tickets*Moray Agn BELROSE AUS	214.50	
01 SEP	CHARITABLE AND SOCIAL SERVIC AMPOL DAWESVILL 55215F DAWESVILLE AUS	78.10	
08 SEP	SERVICE STATIONS AMPOL DAWESVILL 55215F DAWESVILLE AUS	59.35	
13 SEP	SERVICE STATIONS CRIME CHECK AUSTRALIA SYDNEY AUS	99.00	
24 SEP	BUSINESS SERVICES NOT ELSEWH Aqua Valet Car Wash Fa FALCON AUS	19.00	
	CAR WASHES		
	Sub Total:	469.95	
	Miscellaneous Transactions		
29 SEP	TRANSFER CLOSING BALANCE TO BILLING ACCT	469.95 -	
	Sub Total:	469.95 -	
	Grand Total:	0.00	

I have checked the above details and verify that they are correct.

Cardholder Signature Date 10/10/24

Transactions examined and approved.

Manager/Supervisor Signature Date 14/10/24

Credit Card Reconciliation - Page 4						
	Statement From	28/08/2024				
	Statement To	29/09/2024				
Credit Card Transactions - Sarah Caporn, EMWS						
Transaction Date	Statement Description	Amount (incl GST)	GST (\$)	GST (Y/N)	GL/Job	Narration
28/08/2024	Bunnings NORTHAM	\$ 19.00	\$ 1.73	Y	2050287.2101'	CONTAINER FOR DOG FOOD - DEPOT POUND
29/08/2024	MYHOLIDAY - SCARBOROUGH	\$ 545.70	\$ 49.61	Y	121403040.2100	ACCOMMODATION FOR WORKS SUPERVISOR & TLG&G - PROJECT MANAGEMENT TRAINING
31/08/2024	BIG W - MIDLAND	\$ 65.00	\$ 5.91	Y	BO10102.2101	SAFETY BOOTS FOR WORK EXPERIENCE STUDENT
6/09/2024	WARRRL - SUBIACO	\$ 690.00	\$ 62.73	Y	BO10102.2101	6 CARTONS GREEN ONION BAGS FOR WRF
10/09/2024	EASY PEST SUPPLIES	\$ 150.00	\$ 13.64	Y	BM13811.2101	BIND SPIKES FOR SPORTS GROUND
11/09/2024	SHIRE OF QUAIRADING	\$ 200.00	\$ -	N	P432.2400.2101'	NUMBER PLATE ORDER FOR SPORTSGROUND MOWER - 432Q
09/2024	DMIRS EAST PERTH	\$ 44.00	\$ -	N	12140304.2910	RENEWAL OF FORK LIFT LICENSE - DEPOT GENERAL HAND
17/09/2024	SAMARI RESTA SCARBOROUGH	\$ 116.34	\$ 10.58	Y	1240304.2910	MEAL ALLOWANCE FOR DEPOT SUPERVISORS LEADERSHIP TRAINING - STAT DEC
18/09/2024	SAMARI RESTA SCARBOROUGH	\$ 65.97	\$ 6.00	Y	1240304.2910	MEAL ALLOWANCE FOR DEPOT SUPERVISORS LEADERSHIP TRAINING - STAT DEC
19/09/2024	BP WEST COAST - SCARBOROUGH	\$ 24.00	\$ 2.18	Y	1240304.2910	MEAL ALLOWANCE FOR DEPOT SUPERVISORS LEADERSHIP TRAINING - STAT DEC
19/09/2024	BUNNINGS MIDLAND	\$ 211.20	\$ 19.20	Y	W11300.2101	DEPOT - GARDEN TOOLS (RAKE, SHOVELS)

24/09/2024	DRUG ALC TEST EQUIPMENT	\$ 1,725.00	\$ 156.82	Y	12140330.2101	DRUG TEST KITS
24/09/2024	NORTHAM PHARMACY	\$ 83.99	\$ 7.64	Y	12140330.2101	DRUG TEST KITS
26/09/2024	SHIRE OF QUAIRADING	\$ 31.10	\$ -	N	P190.2400.2101	CHANGE OF NUMBER PLATE PRIOR TO ASSET DISPOSAL
26/09/2024	SHIRE OF QUAIRADING	\$ 19.40	\$ -	N	P661.2400.2101	CHANGE OF PLATE NUMBER PLATE ON NEW ASSET
Total		\$ 3,990.70	\$ 336.04			



Electronic Statement

BusinessChoice Everyday Mastercard® Statement

For enquiries please call 1300 650 107 (8am - 8pm, Monday to Friday). Lost or stolen cards service available 24 hours a day, 7 days a week.

Any statement entries for purchases or cash advances made in a foreign currency show the foreign currency transaction amount converted into Australian dollars by the applicable credit card scheme. Any applicable Westpac Foreign Transaction Fee (described below as "Foreign Transaction Fee") charged is shown as a separate entry.

Card Account Transaction Details

Account Name	Card Number	Credit Limit	Available Credit
Mrs Sarah Elizabeth Caporn	5163 2800 0153 8917	5,000	5,000.00
Statement From	Statement To	Facility Number	
28 AUG 2024	29 SEP 2024	02752751	

Summary of Changes in Your Account Since Last Statement

From Your Opening Balance of	We Deducted Payments and Other Credits	And We Added				To Arrive at Your Closing Balance of	Total Past Due / Overlimit balances	Your minimum payment including past due overlimit is
		New purchases	Cash advances	Fees, Interest & Government Charges	Miscellaneous Transactions			
0.00	0.00	3,990.70	0.00	0.00	3,990.70 -	0.00	0.00	0.00

Electronic Statement



Important notice regarding Autopay Direct Debit Arrangement- Direct Debit

* If you have set up a direct debit arrangement for making automatic repayments to your BusinessChoice credit card account, and there have been two failed direct debit transactions (that is, we cannot withdraw the nominated amount from your nominated account) in consecutive months due to insufficient funds in the nominated account, we may, at our sole discretion:

1. Cancel your BusinessChoice Facility Autopay Request Form- Direct Debit Request (New change)
2. Impose a fee or charge (No change- We currently charge a \$15 missed payment fee when payment is not received by statement due date)
3. Charge interest on any unpaid purchases outstanding (No change)

If your Direct Debit Request is cancelled, you must arrange to either set up a new Autopay Request Form- Direct Debit Request or use alternative payment methods so we can process your payment.

Please ensure that there are sufficient funds available in the nominated account to allow direct debit payments to be made in accordance with your BusinessChoice Facility Autopay Request Form- Direct Debit Request.

Please remember any payments made into the Billing account that places the Billing Account into credit or results in a zero balance at the payment due date, your direct debit will still continue to take place. This also applies if you make an additional payment into the Billing Account that is only a partial payment and still leaves a debit balance on the Billing Account, your direct debit arrangement for the month will remain unchanged and continue to take place.

BusinessChoice Everyday Mastercard®			
Date of Transaction	Description	Debits/Credits	Cardholder Comments
	Purchases		
28 AUG	BUNNINGS 603000 NORTHAM AUS HARDWARE STORES	19.00	
29 AUG	MYHOLIDAYWA ACCOMMOD SCARBOROUGH W AUS HOTELS, MOTELS, RESORTS - LO	545.70	
31 AUG	BIG W 0443 MIDLAND AUS VARIETY STORES	65.00	
06 SEP	WARRRL SUBIACO AUS MISCELLANEOUS & SPECIALTY RE	690.00	
10 SEP	SP EASYPESTSUPPLIES CARINGBAH AUS MISCELLANEOUS & SPECIALTY RE	150.00	
11 SEP	SHIRE QUAIRADING QUAIRADING AUS GOVERNMENT SERVICES NOT ELSE	200.00	
11 SEP	DMIRS EAST PERTH EAST PERTH AUS GOVERNMENT SERVICES NOT ELSE	44.00	
17 SEP	SAMARI CAMBODIAN RESTA SCARBOROUGH AUS EATING PLACES, RESTAURANTS	116.34	
18 SEP	SAMARI CAMBODIAN RESTA SCARBOROUGH AUS EATING PLACES, RESTAURANTS	65.97	
19 SEP	BP EXP WEST COAST 6203 SCARBOROUGH AUS SERVICE STATIONS	24.00	
19 SEP	BUNNINGS 591000 MIDLAND AUS HARDWARE STORES	211.20	
24 SEP	DRUG ALC TEST EQUIP CLEVELAND AUS MEDICAL SERVICES NOT ELSEWHE	1,725.00	
24 SEP	NORTHAM PHARMACY PTY L NORTHAM AUS DRUG STORES, PHARMACIES	83.99	
26 SEP	SHIRE QUAIRADING QUAIRADING AUS GOVERNMENT SERVICES NOT ELSE	31.10	
26 SEP	SHIRE QUAIRADING QUAIRADING AUS GOVERNMENT SERVICES NOT ELSE	19.40	

Electronic Statement



BusinessChoice Everyday Mastercard®			
Date of Transaction	Description	Debits/Credits	Cardholder Comments
	Sub Total:	3,990.70	
	Miscellaneous Transactions		
29 SEP	TRANSFER CLOSING BALANCE TO BILLING ACCT	3,990.70 -	
	Sub Total:	3,990.70 -	
	Grand Total:	0.00	

I have checked the above details and verify that they are correct.

Cardholder Signature Slaporn Date 10/10/24

Transactions examined and approved. Daniel Ross

Manager/Supervisor Signature _____ Date 14/10/24

Remember to always keep your passcode secret - don't tell anyone or let them see it. Never write your passcode on your card or on anything that could be lost or stolen. If you do need to record a reminder, you must make every effort to disguise it. You may be liable for losses if you don't protect your passcode.

To help you learn how you can protect your card against unauthorised transactions, you can find more information at westpac.com.au/businessdispute

Important update to your Terms and Conditions

We're updating the Westpac BusinessChoice Cards Terms and Conditions, with effect from 13 December 2022. The update includes additional wording to confirm that a nominated cardholder is authorised to request a replacement card on behalf of the liable party (or parties) where the cardholder's existing card is lost, damaged or stolen, except where the card has been cancelled by the liable party (or parties). Please read these updated Terms and Conditions available at westpac.com.au

Complaints

If you have a complaint, contact our dedicated Customer Solutions team on 132 032 or write to us at Westpac Customer Solutions, Reply Paid 5265, Sydney NSW 2001. If an issue has not been resolved to your satisfaction, you can lodge a complaint with the Australian Financial Complaints Authority (AFCA). AFCA provides fair and independent financial services complaint resolution that is free to consumers.
 Online: www.afca.org.au
 Email: info@afca.org.au
 Phone 1800 931 678
 Mail: Australian Financial Complaints Authority GPO Box 3 Melbourne VIC 3001

Credit Card Reconciliation - Page 5						
Statement From		28/08/2024				
Statement To		29/09/2024				
Credit Card Transactions - Benjamin Davies, CESM						
Transaction Date	Statement Description	Amount (incl GST)	GST (\$)	GST (Y/N)	GL/Job	Narration
4/09/2024	Hungry Birds Pizza Cunderdin	\$ 56.92	\$ -	N	2050765.2100	Quairading BFB refreshments - Training
5/09/2024	CUNDERDIN BP	\$ 200.03	\$ 18.18	Y	PROU002.2610.2101	CESM vehicle fuel
11/09/2024	BP CUNDERDIN	\$ 152.85	\$ 13.90	Y	PROU002.2610.2101	CESM vehicle fuel
15/09/2024	BP CUNDERDIN	\$ 128.93	\$ 11.72	Y	PROU002.2610.2101	CESM vehicle fuel
16/09/2024	PAYPAL EMERG COMPUTER PROGRAMMING	\$ 165.00	\$ 15.00	Y	2050765.2104	BART ALERT SUBSCRIPTION
17/09/2024	CUNDERDIN FARMERS COOP	\$ 206.56	\$ 18.78	Y	2050164.2101	Q BFB STATION MATERIALS/SUPPLIES
24/09/2024	CUNDERDIN FARMERS COOP	154.72	\$ 14.07	Y	2050164.2101	Q BFB STATION MATERIALS/SUPPLIES
24/09/2024	COLES NORTHAM	\$ 25.55	\$ 0.80	Y	2050765.2100	BFB AGM BBQ - QUAIRADING
24/09/2024	BUNNINGS NORTHAM	\$ 52.39	\$ 4.76	Y	PROU002.2600.2101	CESM VEHICLE STORAGE MATERIALS
24/09/2024	GOLFIELDS MEATS CUNDERDIN	\$ 69.75	\$ -	N	2050765.2100	BFB AGM BBQ - TAMMIN (ONCHARGE)
25/09/2024	BP CUNDERDIN	\$ 59.70	\$ 5.43	Y	PROU002.2610.2101	CESM vehicle fuel
Total		\$ 1,272.40	\$ 58.84			



Electronic Statement

BusinessChoice Everyday Mastercard® Statement

For enquiries please call 1300 650 107 (8am - 8pm, Monday to Friday). Lost or stolen cards service available 24 hours a day, 7 days a week.

Any statement entries for purchases or cash advances made in a foreign currency show the foreign currency transaction amount converted into Australian dollars by the applicable credit card scheme. Any applicable Westpac Foreign Transaction Fee (described below as "Foreign Transaction Fee") charged is shown as a separate entry.

Card Account Transaction Details

Account Name	Card Number	Credit Limit	Available Credit
Benjamin Davies	5163 2800 0197 3585	5,000	5,000.00
Statement From	Statement To	Facility Number	
28 AUG 2024	29 SEP 2024	02752751	

Summary of Changes in Your Account Since Last Statement

From Your Opening Balance of	We Deducted Payments and Other Credits	And We Added				To Arrive at Your Closing Balance of	Total Past Due / Overlimit balances	Your minimum payment including past due overlimit is
		New purchases	Cash advances	Fees, Interest & Government Charges	Miscellaneous Transactions			
0.00	0.00	1,272.40	0.00	0.00	1,272.40 -	0.00	0.00	0.00



Electronic Statement

Important notice regarding Autopay Direct Debit Arrangement- Direct Debit

* If you have set up a direct debit arrangement for making automatic repayments to your BusinessChoice credit card account, and there have been two failed direct debit transactions (that is, we cannot withdraw the nominated amount from your nominated account) in consecutive months due to insufficient funds in the nominated account, we may, at our sole discretion:

1. Cancel your BusinessChoice Facility Autopay Request Form- Direct Debit Request (New change)
2. Impose a fee or charge (No change- We currently charge a \$15 missed payment fee when payment is not received by statement due date)
3. Charge interest on any unpaid purchases outstanding (No change)

If your Direct Debit Request is cancelled, you must arrange to either set up a new Autopay Request Form- Direct Debit Request or use alternative payment methods so we can process your payment.

Please ensure that there are sufficient funds available in the nominated account to allow direct debit payments to be made in accordance with your BusinessChoice Facility Autopay Request Form- Direct Debit Request.

Please remember any payments made into the Billing account that places the Billing Account into credit or results in a zero balance at the payment due date, your direct debit will still continue to take place. This also applies if you make an additional payment into the Billing Account that is only a partial payment and still leaves a debit balance on the Billing Account, your direct debit arrangement for the month will remain unchanged and continue to take place.

BusinessChoice Everyday Mastercard®			
Date of Transaction	Description	Debits/Credits	Cardholder Comments
	Purchases		
04 SEP	SMP*Hungry Birds Pizz d0Cunderdin AUS	56.92	
	FAST FOOD RESTAURANTS		
05 SEP	BP CUNDERDIN ROADHOU CUNDERDIN AUS	200.03	
	SERVICE STATIONS		
11 SEP	BP CUNDERDIN ROADHOU CUNDERDIN AUS	152.85	
	SERVICE STATIONS		
15 SEP	BP CUNDERDIN ROADHOU CUNDERDIN AUS	128.93	
	SERVICE STATIONS		
16 SEP	PAYPAL *EMERG EMERG 4029357733 AUS	165.00	
	COMPUTER PROGRAMMING, INTEGR		
17 SEP	Cunderin Farmers Co-O CUNDERDIN AUS	206.56	
	GROCERY STORES, SUPERMARKETS		
24 SEP	Cunderin Farmers Co-O CUNDERDIN AUS	154.72	
	GROCERY STORES, SUPERMARKETS		
24 SEP	COLES 0492COLES 0492 NORTHAM AUS	25.55	
	GROCERY STORES, SUPERMARKETS		
24 SEP	BUNNINGS 603000 NORTHAM AUS	52.39	
	HARDWARE STORES		
24 SEP	GOODFIELD QUALITY ME CUNDERDIN AUS	69.75	
	MISCELLANEOUS FOOD STORES -		
25 SEP	BP CUNDERDIN ROADHOU CUNDERDIN AUS	59.70	
	SERVICE STATIONS		
	Sub Total:	1,272.40	
	Miscellaneous Transactions		
29 SEP	TRANSFER CLOSING BALANCE TO BILLING ACCT	1,272.40 -	
	Sub Total:	1,272.40 -	
	Grand Total:	0.00	

Electronic Statement

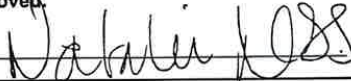

I have checked the above details and verify that they are correct.	
Cardholder Signature 	Date <u>10/10/24</u>
Transactions examined and approved.	
Manager/Supervisor Signature 	Date <u>14/10/24</u>

Remember to always keep your passcode secret - don't tell anyone or let them see it. Never write your passcode on your card or on anything that could be lost or stolen. If you do need to record a reminder, you must make every effort to disguise it. You may be liable for losses if you don't protect your passcode.

To help you learn how you can protect your card against unauthorised transactions, you can find more information at westpac.com.au/businessdispute

Important update to your Terms and Conditions

We're updating the Westpac BusinessChoice Cards Terms and Conditions, with effect from 13 December 2022. The update includes additional wording to confirm that a nominated cardholder is authorised to request a replacement card on behalf of the liable party (or parties) where the cardholder's existing card is lost, damaged or stolen, except where the card has been cancelled by the liable party (or parties). Please read these updated Terms and Conditions available at westpac.com.au

Complaints

If you have a complaint, contact our dedicated Customer Solutions team on 132 032 or write to us at Westpac Customer Solutions, Reply Paid 5265, Sydney NSW 2001. If an issue has not been resolved to your satisfaction, you can lodge a complaint with the Australian Financial Complaints Authority (AFCA). AFCA provides fair and independent financial services complaint resolution that is free to consumers.

Online: www.afca.org.au

Email: info@afca.org.au



Phone 1800 931 678

Mall: Australian Financial Complaints Authority GPO Box 3 Melbourne VIC 3001

11.3 Purchase of Hospital Auxiliary Community Car

Responsible Officer Natalie Ness, Chief Executive Officer

Reporting Officer Tricia Brown, Executive Manager, Corporate Services

- Attachments**
1. Attachment (i) Quote 8184 - Avon Valley Northam - Preferred Quote [↓](#) 
 2. Attachment (ii) Quote 8916 - Avon Valley Merredin [↓](#) 
 3. Attachment (iii) Quote 9569 - Avon Valley Northam [↓](#) 

Voting Requirements Simple Majority

Disclosure of Interest Reporting Officer: Nil
Responsible Officer: Nil

RESOLUTION: OCM 063-24/25

Moved: Cr RC Faltyn

Seconded: Cr BR Cowcill

That Council;

1. Accept the Quotation received from Avon Valley Toyota (Northam) (Attachment (i) for the supply and delivery of one (1) new 2024 Toyota Camry 2.5L Hybrid Ascent and the Trade of one (1) 2020 Toyota Camry Ascent
2. Note the Capital Budget of \$38,187.01 incl GST to be fully fundable by the trade in of the current Community Car of \$16,500 inc GST and a Capital Contribution by the Hospital Auxiliary of \$21,687.00 inc GST.

FOR: Crs JN Haythornthwaite, TJ Stacey, BR Cowcill, RC Faltyn, EV Gom, JC Hayes and JR Hippisley

AGAINST: Nil

CARRIED 7/0

IN BRIEF

- A meeting was held between Phyllis Brown on behalf of the Hospital Auxiliary, CEO, and EMCS where the Hospital Auxiliary requested a new Community Car be purchased by Council.
- The Hospital Auxiliary will be reimbursing the full changeover cost of the vehicle.
- Three quotes were obtained from Avon Valley Toyota Northam and Avon Valley Toyota Merredin.
- Avon Valley Toyota Northam is the recommended supplier with the best value in terms of price and availability with a changeover price of \$21,687. The vehicle chosen is currently in stock however other vehicles require a three (3) month supply time.

MATTER FOR CONSIDERATION

For Council to agree to the budgeted expenditure of \$21,687.00 incl GST to purchase a new 2024 Toyota Camry Hybrid Ascent and Trade in a 2020 Toyota Camry Ascent, for the Hospital Auxiliary Community Car.

BACKGROUND

The Hospital Auxiliary Committee requested a new Community Car, with the intention of Council initially purchasing the vehicle to be eligible for Local Government discounts, and the Hospital Auxiliary reimbursing the full amount.

The Hospital Auxiliary Committee favoured a similar type of vehicle to what they already have. After consultation with Phyllis Brown who negotiated the trade in vehicle in Northam, it was decided that a 2024 Toyota Camry 2.5L Hybrid Ascent was the best fit for their needs.

Three quotes were obtained, 2 from Avon Valley Northam and 1 from Avon Valley Merredin. The best in terms of value and availability is Avon Valley (Northam) with a changeover price of \$21,687.00, and currently available in stock.

STATUTORY ENVIRONMENT

Local Government Act 1995

6.8. Expenditure from municipal fund not included in annual budget

- (1) A local government is not to incur expenditure from its municipal fund for an additional purpose except where the expenditure —
 - (a) is incurred in a financial year before the adoption of the annual budget by the local government; or
 - (b) is authorised in advance by resolution*; or
 - (c) is authorised in advance by the mayor or president in an emergency.

** Absolute majority required.*

POLICY IMPLICATIONS

Purchasing Policy

The Shire of Quairading Purchasing Policy requires three (3) written quotes from suitable suppliers for purchases between \$20,001 and up to \$50,000 (ex GST).

FINANCIAL IMPLICATIONS

There are no budget implications as Council has already endorsed the purchase within the 2024/2025 Budget.

The cost of the vehicle will be fully funded by the value of the trade in vehicle, and a contribution from the Hospital Auxiliary Committee.

ALIGNMENT WITH STRATEGIC PRIORITIES

- 5.4 **Governance & Leadership:** Implement systems and processes that meet legislative and audit obligations

CONSULTATION

A meeting was originally held with Phyllis Brown on behalf of the Hospital Auxiliary Committee who requested a new Community Car. Consultation continued throughout the process with Phyllis Brown of the Hospital Auxiliary Committee.

RISK MANAGEMENT PRIORITIES

This report addresses the following identified Strategic Risk Management Priorities:

Nil.

RISK ASSESSMENT

	Option 1
Financial	Low <i>The cost is neutral to the Shire</i>
Health	Medium The Community Car provides travel assistance to members of the public who require this service to attend important appointments. If this service was not able to continue, there is a risk that those who are dependent on the service will be unable to access medical services/care.
Reputation	Medium This is an important Health Service to the Community that the Council supports through the provision of Administration Services for running a Vehicle. If the service is not able to run there may be reputational damage to the Council for not supporting local health initiatives.
Operations	Low
Natural Environment	Low <i>Hybrid Vehicle</i>

Likelihood	Consequence				
	Insignificant	Minor	Moderate	Major	Critical
Rare	LOW Accept the risk Routine management	LOW Accept the risk Routine management	LOW Accept the risk Routine management	MEDIUM Specific responsibility and treatment	HIGH Quarterly senior management review
Unlikely	LOW Accept the risk Routine management	LOW Accept the risk Routine management	MEDIUM Specific responsibility and treatment	MEDIUM Specific responsibility and treatment	HIGH Quarterly senior management review
Possible	LOW Accept the risk Routine management	MEDIUM Specific responsibility and treatment	MEDIUM Specific responsibility and treatment	HIGH Quarterly senior management review	HIGH Quarterly senior management review
Likely	MEDIUM Specific responsibility and treatment	MEDIUM Specific responsibility and treatment	HIGH Quarterly senior management review	HIGH Quarterly senior management review	EXTREME Monthly senior management review
Almost certain	MEDIUM Specific responsibility and treatment	MEDIUM Specific responsibility and treatment	HIGH Quarterly senior management review	EXTREME Monthly senior management review	EXTREME Monthly senior management review

COMMENT

On behalf of the Hospital Auxiliary and Committee, the Community Car continues to provide a high-quality service to vulnerable members of our community.

The Hospital Auxiliary relies on low kilometre trade-ins to obtain a better change over price on new vehicles.

COMMENTS

Cr Hippisley enquired whether the transaction through the Shire was intended as a benefit to the Hospital Auxiliary Committee. The CEO replied that it was and further explained that the EMCS was preparing a written Memorandum Of Understanding with the Committee, as the agreement had so far been verbal.

Cr Stacey asked about the ownership of the vehicle and insurance for the different drivers. The CEO took the question on notice and added that clarifying questions of that nature was exactly the reason why an MOU was necessary.



Avon Valley Toyota
32 Fitzgerald Street,
Northam, WA 6401

T 08 9622 5622
sales@avtoyota.com.au
www.avtoyota.com.au

B5B: 066524 ACC: 10221520
ABN: 88 381 337 938 ACN: 122 640 617
DL 20461 MRB 4293 ARC AU44109

QUOTATION

QUOTATION FOR :	
Shire of Quairading Po Box 38 Quairading WA 6383 E: dceo@quairading.wa.gov.au M: 0499699086	DATE : 15/03/2024 QUOTE : 8184 (6) DEPT : 111 AV Fleet Sales Toyota REP : Tracey Burges STOCK No :

QUOTATION DETAILS	PRICE
MOTOR VEHICLE	
Camry 2.5L Hybrid CVT Ascent 2Z76740 001	\$34,470.00 Factory Option (A0)
Approved Government	\$2,000.00-
ACCESSORIES / OPTIONS	
FACTORY OPTIONS	
Vehicle Colour – Silver Pearl	\$522.73
Vehicle Trim – Dark Grey Fabric	Included
Ascent	Included (Factory Fitted Option)
NON-GENUINE ACCESSORIES	
Carpet Floor Mats included	Included
DEALER CHARGES	
Dealer Delivery	\$1,722.73
Complimentary Tank of Fuel	Included
TOTAL PRICE (Excl. GST)	\$34,715.46
TOTAL	\$34,715.46
Total GST	\$3,471.55
TOTAL PAYABLE	\$38,187.01
TRADE DETAILS (Incl GST)	
CAMRY	\$16,500.00- Registration Q5335
BALANCE PAYABLE	\$21,687.00
PLEASE NOTE:	
Quote is valid until 31st October 2024	
On roads to be charged at Cost.	



Avon Valley Toyota
32 Fitzgerald Street,
Northam, WA 6401

T 08 9622 5622
sales@avtoyota.com.au
www.avtoyota.com.au

B5B: 066524 ACC: 10221520
ABN: 88 381 337 938 ACN: 122 640 617
DL 20461 MRB 4293 ARC AU44109

QUOTATION

QUOTATION FOR :	QUOTE DETAILS
Shire of Quairading Po Box 38 Quairading WA 6383 E: dceo@quairading.wa.gov.au M: 0499699086	DATE : 15/03/2024 QUOTE : 8184 (6) DEPT : 111 AV Fleet Sales Toyota REP : Tracey Burges STOCK No :

QUOTATION DETAILS	PRICE
<p>We have this vehicle in stock currently</p> <p>Trade value is valid for 30 days</p>	

*NOTE - This quotation is valid for 7 days upon signature of manager.

Tracey Burges
Sales Executive

Authorised Manager



Avon Valley Toyota
32 Fitzgerald Street,
Northam, WA 6401

T 08 9622 5622
sales@avtoyota.com.au
www.avtoyota.com.au

B5B: 066524 ACC: 10221520
ABN: 88 381 337 938 ACN: 122 640 617
DL 20461 MRB 4293 ARC AU44109

QUOTATION

QUOTATION FOR :	QUOTE DETAILS
Shire Of Quairading Po Box 38 Quairading WA 6383 E: accounts@quairading.wa.gov.au M: 0429451245	DATE : 28/06/2024 QUOTE : 8916 (2) DEPT : 211 Merredin Fleet Sales Toyota REP : Tanya Withers STOCK No :

QUOTATION DETAILS	PRICE
MOTOR VEHICLE	
Camry 2.5L Hybrid CVT Ascent 2Z76740 001 Approved Government	\$37,917.00 Factory Option (A0) \$2,200.00-
ACCESSORIES / OPTIONS	
FACTORY OPTIONS	
Vehicle Colour – Silver Pearl	\$575.00
Vehicle Trim – Dark Grey Fabric	Included
Ascent	Included (Factory Fitted Option)
NON-GENUINE ACCESSORIES	
All Weather Rubber Floor Mats – Front and Rear	Included
DEALER CHARGES	
Dealer Delivery	\$1,895.00
Complimentary Tank of Fuel	Included
TOTAL PRICE	<u>\$38,187.00</u> Inc. GST
TOTAL PAYABLE	<u>\$38,187.00</u>
Includes GST \$3,471.55	
TRADE DETAILS (Incl GST)	
	\$17,000.00- Registration Q5335
BALANCE PAYABLE	<u>\$21,187.00</u>

*NOTE - This quotation is valid for 7 days upon signature of manager.

Tanya Withers
Sales Executive

Authorised Manager



Avon Valley Toyota
32 Fitzgerald Street,
Northam, WA 6401

T 08 9622 5622
sales@avtoyota.com.au
www.avtoyota.com.au

B5B: 066524 ACC: 10221520
ABN: 88 381 337 938 ACN: 122 640 617
DL 20461 MRB 4293 ARC AU44109

QUOTATION

QUOTATION FOR :	
Shire of Quairading Po Box 38 Quairading WA 6383 E: dceo@quairading.wa.gov.au M: 0499699086	DATE : 14/10/2024 QUOTE : 9569 (2) DEPT : 111 AV Fleet Sales Toyota REP : Tracey Burges STOCK No :

QUOTATION DETAILS	PRICE
MOTOR VEHICLE	
Camry 2.5L Hybrid CVT Ascent 2V03600 001	\$36,354.55 Factory Option (A0)
Approved Government	\$1,500.00-
ACCESSORIES / OPTIONS	
FACTORY OPTIONS	
Vehicle Colour – Glacier White	Included
Vehicle Trim – Black Fabric	Included
Ascent	Included (Factory Fitted Option)
NON-GENUINE ACCESSORIES	
Carpet Floor Mats included	Included
DEALER CHARGES	
Dealer Delivery	\$1,722.73
Complimentary Tank of Fuel	Included
TOTAL PRICE (Excl. GST)	\$36,577.28
TOTAL	\$36,577.28
Total GST	\$3,657.73
TOTAL PAYABLE	\$40,235.01
TRADE DETAILS (Incl GST)	
CAMRY	\$16,500.00- Registration Q5335
BALANCE PAYABLE	\$23,735.01
PLEASE NOTE:	
Quote is valid until 31st October 2024	
On roads to be charged at Cost.	



Avon Valley Toyota
32 Fitzgerald Street,
Northam, WA 6401

T 08 9622 5622
sales@avtoyota.com.au
www.avtoyota.com.au

B5B: 066524 ACC: 10221520
ABN: 88 381 337 938 ACN: 122 640 617
DL 20461 MRB 4293 ARC AU44109

QUOTATION

QUOTATION FOR :	QUOTE DETAILS
Shire of Quairading Po Box 38 Quairading WA 6383 E: dceo@quairading.wa.gov.au M: 0499699086	DATE : 14/10/2024 QUOTE : 9569 (2) DEPT : 111 AV Fleet Sales Toyota REP : Tracey Burges STOCK No :

QUOTATION DETAILS	PRICE
<p>This vehicle will be a factory order</p> <p>Trade value is valid for 30 days</p>	

*NOTE - This quotation is valid for 7 days upon signature of manager.

Tracey Burges
Sales Executive

Authorised Manager

ITEM 12 MATTERS FOR CONSIDERATION – GOVERNANCE & ADMINISTRATION

12.1 Council meeting dates for the 2025 calendar year

Responsible Officer Natalie Ness, Chief Executive Officer

Reporting Officer Marion Haeusler, Executive Officer

Attachments Nil

Voting Requirements Simple Majority

Disclosure of Interest Reporting Officer: Nil
Responsible Officer: Nil

RESOLUTION: OCM 064-24/25

Moved: Cr TJ Stacey

Seconded: Cr JR Hippisley

That Council:

1. adopt the following dates for the 2025 Ordinary Council Meetings commencing at 2.00pm at the Council Chambers in Quairading:
 - Thursday, 27th February 2025
 - Thursday, 27th March 2025
 - Thursday, 24th April 2025
 - Thursday, 29th May 2025
 - Thursday, 26th June 2025
 - Thursday, 31st July 2025
 - Thursday, 28th August 2025
 - Thursday, 25th September 2025
 - Thursday, 30th October 2025
 - Thursday, 27th November 2025
 - Thursday, 18th December 2025
2. adopt the following dates for the 2025 Audit & Risk Committee Meetings commencing at 5.00pm at the Council Chambers in Quairading:
 - Tuesday, 11th February 2025
 - Tuesday, 13th May 2025
 - Tuesday, 12th August 2025
 - Tuesday, 11th November 2025
3. approve the publishing of the Council and Committee meeting dates, times, and location in the Banksia Bulletin and on the Shire social media pages in addition to legislative requirements.

FOR: Crs JN Haythornthwaite, TJ Stacey, BR Cowcill, RC Faltyn, EV Gom, JC Hayes and JR Hippisley

AGAINST: Nil

CARRIED 7/0

IN BRIEF

Each year Council is legally compelled to set the dates for Ordinary Council Meetings and Audit & Risk Committee Meetings. The CEO is responsible for publishing the meeting schedule.

Council officers have suggested dates which coincide with previous practice and include changes where necessary or practical.

Council does have the opportunity to amend the frequency, dates and times of Council and Committee meetings.

MATTER FOR CONSIDERATION

Councillors need to decide whether they agree with the meeting schedule as presented in the Officer Recommendation.

BACKGROUND

Ordinary Council Meetings are currently held on the last Thursday of the month, except in January and December for the following reasons:

- In 2007 Council resolved to not hold an Ordinary Council Meeting in January to enable a holiday recess for Elected Members and Council Officers.
- December meetings are held earlier in the month to allow for the Administration Christmas closure period.

According to the following schedule of Public Holidays in WA for the 2025 calendar year, no Public Holiday coincides with the regular meeting schedule for both Ordinary Council Meetings and Audit & Risk Committee Meetings:

2025	
New Year’s Day	Wednesday, 1 st January
Australia Day	Monday, 27 th January
Labour Day	Monday, 3 rd March
Good Friday	Friday, 18 th April
Ester Sunday	Sunday, 20 th April
Easter Monday	Monday, 21 st April
Anzac Day	Friday, 25 th April
Western Australia Day	Monday, 2 nd June
King’s Birthday	Monday, 29 th September
Christmas Day	Thursday, 25 th December
Boxing Day	Friday, 26 th December

The Audit & Risk Committee Meeting is currently held four times a year on the second Tuesday of the allocated month.

The schedule suggested in the Officer Recommendation prevents the Committee Meeting date being too close to the OCM meeting date suggested for December while still allowing for an even spacing of meetings at three months apart.

According to the *Local Government (Administration) Regulations 1996* the CEO is obliged to publish meeting details for Ordinary Council Meetings and committee meetings required under the Act (i.e., Audit & Risk) to the Shire website for public information before the commencement of the calendar year in which the meetings are to be held. Officers recommend the additional publication in other types of media to inform a greater number of community members.

STATUTORY ENVIRONMENT

Local Government Act 1995

Local Government (Administration) Regulations 1996

POLICY IMPLICATIONS

Nil

FINANCIAL IMPLICATIONS

There are no financial implications associated with the setting of Council and Committee Meeting dates

ALIGNMENT WITH STRATEGIC PRIORITIES

- 5.1 Governance & Leadership:** Shire communication is consistent, engaging and responsive
- 5.2 Governance & Leadership:** Forward planning and implementation of plans to determine Strategic Plan and service levels
- 5.3 Governance & Leadership:** Provide informed and transparent decision making that, meets our legal obligations, and the needs of our diverse community
- 5.4 Governance & Leadership:** Implement systems and processes that meet legislative and audit obligations

CONSULTATION

Nil

RISK MANAGEMENT PRIORITIES

This report addresses the following identified Strategic Risk Management Priorities:

Nil.

RISK ASSESSMENT

	Option 1
Financial	Low <i>Nil</i>
Health	Low <i>Nil</i>

Reputation	High <i>It is a statutory requirement for Council to set Council and Committee Meeting dates to publish on the Shire website for public information. Should a member of the public want to attend or submit a question to a Council Meeting and the information is not available it will reflect poorly on the Shire.</i>
Operations	Low <i>There will be some staff time allocated to advertising the dates, but this is within normal scope of work.</i>
Natural Environment	Low <i>Nil</i>

	Consequence				
Likelihood	Insignificant	Minor	Moderate	Major	Critical
Rare	LOW Accept the risk Routine management	LOW Accept the risk Routine management	LOW Accept the risk Routine management	MEDIUM Specific responsibility and treatment	HIGH Quarterly senior management review
Unlikely	LOW Accept the risk Routine management	LOW Accept the risk Routine management	MEDIUM Specific responsibility and treatment	MEDIUM Specific responsibility and treatment	HIGH Quarterly senior management review
Possible	LOW Accept the risk Routine management	MEDIUM Specific responsibility and treatment	MEDIUM Specific responsibility and treatment	HIGH Quarterly senior management review	HIGH Quarterly senior management review
Likely	MEDIUM Specific responsibility and treatment	MEDIUM Specific responsibility and treatment	HIGH Quarterly senior management review	HIGH Quarterly senior management review	EXTREME Monthly senior management review
Almost certain	MEDIUM Specific responsibility and treatment	MEDIUM Specific responsibility and treatment	HIGH Quarterly senior management review	EXTREME Monthly senior management review	EXTREME Monthly senior management review

COMMENT

Nil

COMMENTS

Cr Stacey brought up the possibility of changing the start time of the Council Meetings to accommodate a more varied demographic. Cr Haythornthwaite asked for the topic to be included in a future Concept Forum.

Cr Stacey further asked when the changes to the structure of the Audit & Risk Committee are expected to come into effect. The CEO answered that changes were not expected to come into effect the new financial year and Cr Haythornthwaite added that a change to the Audit & Risk Committee Meeting schedule could be made at the time through advertising to the community

12.2 Voluntary Alcohol Self Testing Policy - Biennial Review

Responsible Officer Natalie Ness, Chief Executive Officer

Reporting Officer Marion Haeusler, Executive Officer

Attachments 1. Voluntary Alcohol Self Testing Policy [↓](#) 

Voting Requirements Simple Majority

Disclosure of Interest Reporting Officer: Nil
Responsible Officer: Nil

RESOLUTION: OCM 065-24/25

Moved: Cr JC Hayes

Seconded: Cr RC Faltyn

That Council endorse the review of the Voluntary Alcohol Self Testing Policy

FOR: Crs JN Haythornthwaite, TJ Stacey, BR Cowcill, RC Faltyn, EV Gom, JC Hayes and JR Hippisley

AGAINST: Nil

CARRIED 7/0

IN BRIEF

The Voluntary Alcohol Self Testing Policy was adopted by Council at its Ordinary Meeting in October 2022.

Officers have reviewed the Policy (Attachment 1) for Council’s endorsement.

MATTER FOR CONSIDERATION

The Shire of Quairading routinely reviews its Policies on a biennial basis, as prescribed, or when necessary. Policies are reviewed against Shire processes and procedures, changes in legislation, and for clarity in wording.

Officers have amended the Policy to remove any mention of a specific make and model of breathalyser and included instead the stipulation that a device used by the Shire for the purposes of testing the Breath Alcohol Concentration (BAC) must be certified to the Australian Standard AS 3547 – Breath Alcohol Testing Devices for Personal Use.

BACKGROUND

The Shire of Quairading has a duty of care to all workers and visitors, to ensure they can perform their role in a safe manner, and not cause harm to themselves, others or Council property.

Council has a range of staff that perform a variety of roles, some tasks of which are considered high risk.

Shire Officers originally developed the Policy to put transparent guidelines in place that adhere to the *Work Health & Safety Act 2020* as well as Federal and State legislation to encourage staff to assess their fitness for work and if they consider themselves under the influence of alcohol, to mitigate the risk by self-testing their Breath Alcohol Concentration or BAC.

This Policy applies in situations where an employee indicates of their own accord the possibility that they may be under the influence of alcohol and provides them and their management with a procedure to manage this situation in a fair manner if required.

Although the Shire regularly conducts random drug and alcohol testing as per the Drug & Alcohol Policy & Testing Procedures, this Policy represents an approach of leniency in the case of responsible self-management of the possible influence of alcohol only by an employee.

STATUTORY ENVIRONMENT

Local Government Act 1995

Work Health & Safety Act 2020

Work Health & Safety Regulations 2011

POLICY IMPLICATIONS

Risk Management Policy

Work Health & Safety Policy

Drug & Alcohol Policy & Testing Procedure

FINANCIAL IMPLICATIONS

The hand-held portable testing unit is already owned by the Shire. Calibration of the device in 6-monthly intervals cost \$183 per year and the disposable mouthpieces are purchased at approximately \$45 per 100pc.

ALIGNMENT WITH STRATEGIC PRIORITIES

- 5.3 Governance & Leadership:** Provide informed and transparent decision making that, meets our legal obligations, and the needs of our diverse community
- 5.4 Governance & Leadership:** Implement systems and processes that meet legislative and audit obligations

CONSULTATION

Nil

RISK MANAGEMENT PRIORITIES

This report addresses the following identified Strategic Risk Management Priorities:

Non-compliance with work health and safety legislation increases the risk and potential liability to the public, staff and Councillors.

RISK ASSESSMENT

	Option 1
Financial	High <i>Executive Management, Elected Members & staff can be held liable for any serious workplace injury or death.</i>
Health	High <i>Any person carrying out duties on behalf of the Shire will put themselves, other people and Council property at risk should they be working in any capacity under the influence of alcohol.</i>
Reputation	High <i>Council staff are constantly in the public eye. It would be detrimental to Councils image if staff or Elected Members are operating at work under the influence of alcohol.</i>
Operations	Low
Natural Environment	N/A

	Consequence				
Likelihood	Insignificant	Minor	Moderate	Major	Critical
Rare	LOW Accept the risk Routine management	LOW Accept the risk Routine management	LOW Accept the risk Routine management	MEDIUM Specific responsibility and treatment	HIGH Quarterly senior management review
Unlikely	LOW Accept the risk Routine management	LOW Accept the risk Routine management	MEDIUM Specific responsibility and treatment	MEDIUM Specific responsibility and treatment	HIGH Quarterly senior management review
Possible	LOW Accept the risk Routine management	MEDIUM Specific responsibility and treatment	MEDIUM Specific responsibility and treatment	HIGH Quarterly senior management review	HIGH Quarterly senior management review
Likely	MEDIUM Specific responsibility and treatment	MEDIUM Specific responsibility and treatment	HIGH Quarterly senior management review	HIGH Quarterly senior management review	EXTREME Monthly senior management review
Almost certain	MEDIUM Specific responsibility and treatment	MEDIUM Specific responsibility and treatment	HIGH Quarterly senior management review	EXTREME Monthly senior management review	EXTREME Monthly senior management review

COMMENT

Nil



VOLUNTARY SELF TESTING ALCOHOL POLICY

PURPOSE

To define the requirements for the voluntary self-assessment of Breath Alcohol Concentration (BAC) using an onsite portable breathalyser unit that is certified to comply with Australian Standard AS 3547 – Breath Alcohol Testing Devices for Personal Use.

All workers and other persons at the workplace have a duty of care under the *Work Health and Safety Act 2020* not to wilfully place at risk the workplace health and safety of any person at the workplace and not to wilfully injure themselves. The use of the supplied self-testing device can assist the workers and other persons at a workplace to meet their obligation under the act in relation to BAC.

OBJECTIVE

The objective of this policy is to provide the tools, appropriate knowledge and skills and for the self-management of alcohol in the workplace. Meeting this object will:

- Minimise the risk to the individual, their colleagues, visitors and the public by encouraging individuals to utilise equipment and devices provided by Council to self-assess their fitness for work;
- Encourage persons who find themselves affected by alcohol to take the appropriate action so as to ensure there is a safe and healthy work environment for them and their workmates.

SCOPE

This Policy applies to all employees of Shire of Quairading, clients, contractors and visitors.

ROLES & RESPONSIBILITIES

Council understands that creating and maintaining a safe and healthy working environment is a major part of Council's overall responsibilities, and that all employees with management and supervisory responsibilities are accountable for the health and safety of employees and visitors in their respective work areas and managed facilities.

Managers and Supervisors are responsible for:

- Under workplace health and safety legislation, ensuring their own health and safety, the health and safety of employees and the health and safety of others in the workplace.
- Personally, demonstrating appropriate behaviour and promoting this Policy.
- Ensuring that employees are not under the influence of alcohol in the workplace.
- Ensuring that complaints of non-compliance received either informally or formally, are dealt with promptly.

VOLUNTARY SELF TESTING ALCOHOL POLICY



The Chief Executive Officer and Executive Managers are responsible for ensuring that staff understand and adhere to this policy. The Chief Executive Officer has primary responsibility for dealing with complaints and ensuring that the process is followed.

Employees are to abide by the Policy and report to supervisors any breaches of this Policy.

DEFINITIONS

The following definitions are provided for the purposes of interpretation and application of the policy.

Council – Quairading Shire Council

BAC – Breath Alcohol Concentration

High Risk Work Activities – include but not limited to:

- High risk construction activities as defined in the Work Health and Safety Regulation 2011, Section 291
- High Risk Work Licence (Forklift; EWP; Crane; Dogging; Scaffolding)
- Confined space work
- Traffic control
- Explosive power tools
- Firearms
- Operation of a chainsaw
- Operation of wood chippers
- Operation of dingo/stump grinder
- Operation of vehicle loading crane
- Operation of a demolition or concrete saw
- Working with electricity or electrical components (240V or higher)
- Operation of RPA (Remotely Piloting Aircraft)

POLICY**1 Actions and Assessment Tools**

The maximum acceptable BAC level for Council workplaces is 0.049% (any reading equal to or greater than 0.05% is considered a positive result).

To increase the awareness of the effects of alcohol consumption and BAC levels, a Certified breathalyser, conforming to Australian Standard AS 3547 will be available for staff to utilise for self-testing.

The alcotest is provided for voluntary self-assessment purposes only as a means for employees, contractors and visitors to self-assess their fitness for duty in relation to the BAC levels.

The alcotest may be used at any time by any person at any council site that has one available.



1.1 AS 3547 Certified Breathalyser

The breathalyser used by the Shire is a portable unit which will allow staff, contractors and visitors access to highly accurate Australian Standard testing equipment that produces results that do not identify the individual. The device will be able to detect if there is a BAC reading above or below .05% and therefore will allow the donor to make an assessment on their fitness for duty. The breathalyser has been calibrated in accordance with the manufacturer's specification with calibration of the unit being undertaken every 6 months. Instructions for how to use the unit are displayed on each unit and a copy of the testing outcomes flow chart will also be located with the unit.

2 How to use the Equipment & Testing Outcome Actions

The breathalyser that has been supplied by council to staff, visitors and contractors to assist by identifying their fitness for work must be used in conjunction with the manufacturer's instructions and recommendations.

2.1 Using the Alcotest

Where a worker, supervisor, manager, contractor or visitor intends to voluntarily self-test for BAC, it is strongly recommended that they do so immediately prior to their commencement of work. This allows the individual to take action on an outcome that produces a positive test (equal to or above 0.05%) before they commence or recommence work, so that neither the individual concerned, nor any other person is placed at risk. Council is responsible to ensure the unit is within calibration date.

You will need to re-test on the Council provided equipment before commencing your next shift to obtain a negative result.

The instructions on how to use the breathalyser unit are provided with the device. Please refer to these manufacturer's instructions to ensure an accurate result is obtained.

2.2 Recommended Actions for a Person who tests equal to or greater than 0.05%

Where an individual tests "positive" (i.e. equal to or greater than 0.05%) they should not commence work. They should wait at least 20 minutes and undertake a second test.

Where an individual's second self-test shows that the person BAC levels exceeds the maximum prescribed BAC limited (equal to or greater than 0.05%), it is strongly advised, and they are obliged not to commence work – to do so is a breach of their obligation under the *Work Health and Safety Act 2020*.

The person is not required to inform their supervisor of the positive test but must inform their supervisor of the fact they are not attending work for their current shift due to not being "fit for work".

If the test result is over the alcohol limit for the class of licence the person holds – they must not drive themselves home as per the Road Traffic Act 1974.

VOLUNTARY SELF TESTING ALCOHOL POLICY



Licence or situation	Legal BAC
Open licence holders	Below 0.05%
Novice driver (novice driver has not held a driver’s licence for a total period of 2 or more years)	0.00%
You have been recently disqualified for certain alcohol or drug related offences.	0.00%
You are a holder of an Extraordinary Licence.	0.00%
You are an alcohol offender	0.00%
You are a driver of a: <ul style="list-style-type: none"> • Bus (vehicle equipped to seat more than 12 adults, including the driver). • Vehicle carrying passengers for hire and reward (Uber; Ola; Taxi, Small Charter Vehicle etc.). • Vehicle carrying dangerous goods. • Vehicle of or over 22.5t GCM 	0.00%

If a Council employee requires transport home after they have informed their supervisor, they are not fit for work they have the option of:

- Requesting that their supervisor arrange their transport home; or
- Ringing a family member or friend to organise transport home.

The employee may apply for an appropriate form of leave to cover the duration of the absence due to being unfit for duty.

Where a contractor, consultant or visitor has voluntarily self-tested and has a BAC above the acceptable limit in accordance with this policy they should not commence work. The contractor or contractor’s supervisor will be responsible for organising transportation.

3 Facts & Tips for Managing Self-Testing Outcomes

Listed below are some facts to assist the individual with managing their own testing and outcomes:

- The breathalyser unit readings are considered to be accurate at the time of the test
- A person BAC can rise for 1 hour or more after their last drink;
- Voluntary self-testing results can only be seen by the individual & will not be recorded and will not become part of any disciplinary process.
- Although you are obliged under the *Work Health and Safety Act 2011* to advise your supervisor if you obtain a positive reading (equal to or greater than 0.05%) you are not obliged to divulge the result detail.

VOLUNTARY SELF TESTING ALCOHOL POLICY



- Under no circumstances can you drive yourself home if you record a positive alcohol result. Arrangements will need to be made by your supervisor or by yourself to ensure you are transported safely to your home or place of rest.
- If you record a reading below 0.05% you can still remain at work however you will be allocated duties that do not include high risk activities until your reading reaches 0.00%.
- People who would like information on alcohol or other drug related problems or would like to discuss such issues can talk confidentially to the Council’s Workplace Health & Safety Officer.

4 Leave Provisions

Should the employee be obliged to go home following a positive alcohol reading they may apply for an appropriate form of leave to cover the duration of the absence due to being unfit for duty.

This will depend on the terms of engagement the individual has with Council and may come in the form of:

- Annual Leave
- Time off in lieu
- Rostered day off
- Sick leave
- Leave without pay

GUIDELINES

Appendix 1 – Flowchart for Managing Self-Test Results

Work Health & Safety Act 2020

Work Health & Safety Regulation 2011

Road Traffic Act 1974 (WA)

Shire of Quairading Drug & Alcohol Policy

STATUTORY ENVIRONMENT

Work Health & Safety Act 2020

Work Health & Safety Regulation 2011

Road Traffic Act 1974 (WA)

VOLUNTARY SELF TESTING ALCOHOL POLICY





Record of Policy Review						
Version	Author	Council Adoption	Resolution	Reason for Review	Next Review Date	CEO Signature
01	Nicole Gibbs	27/10/22	98 – 22/23	New Policy	Oct 2024	<i>Nicole Gibbs</i>

VOLUNTARY SELF TESTING ALCOHOL POLICY

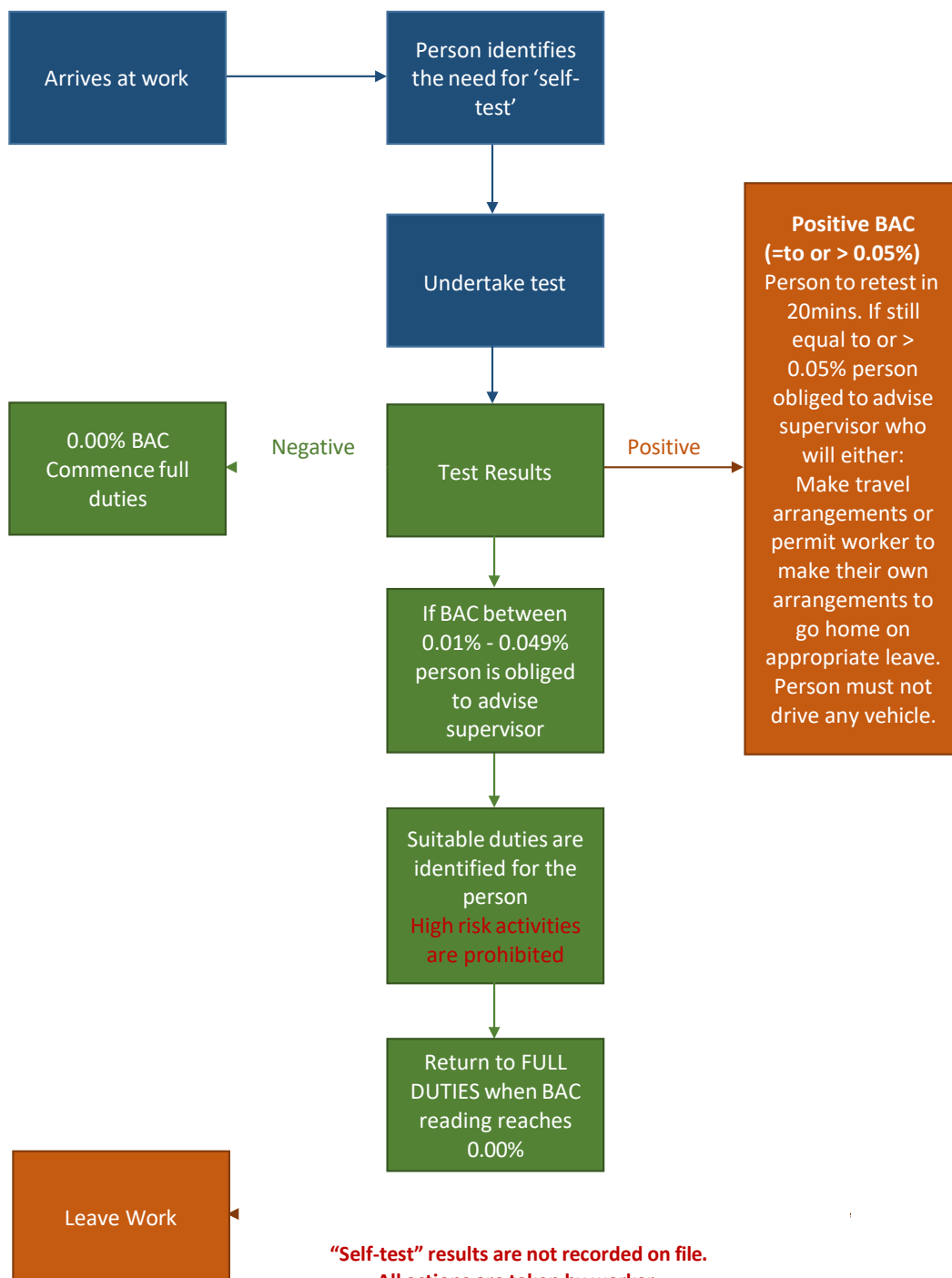

Appendix 1 – Flowchart for Managing Self-Test Results



12.3 Urban and Rural Street Addressing Policy - Biennial Review**Responsible Officer** Natalie Ness, Chief Executive Officer**Reporting Officer** Marion Haeusler, Executive Officer**Attachments** 1. Urban and Rural Street Addressing Policy [↓](#) **Voting Requirements** Simple Majority**Disclosure of Interest** Reporting Officer: Nil

Responsible Officer: Nil

RESOLUTION: OCM 066-24/25

Moved: Cr JC Hayes

Seconded: Cr TJ Stacey

That Council endorse the review of the Urban and Rural Street Addressing Policy.

FOR: Crs JN Haythornthwaite, TJ Stacey, BR Cowcill, RC Faltyn, EV Gom, JC Hayes and JR Hippisley**AGAINST:** Nil**CARRIED 7/0****IN BRIEF**

The Urban and Rural Street Addressing Policy was adopted by Council at its Ordinary Meeting in June 2022.

Officers have reviewed the Policy (Attachment 1) for Council's endorsement.

MATTER FOR CONSIDERATION

The Shire of Quairading routinely reviews its Policies on a biennial basis, as prescribed, or when necessary. Policies are reviewed against Shire processes and procedures, changes in legislation, and for clarity in wording.

Officers have amended the Policy for formatting and minor punctuation errors as well as made change to section 3.b. under Urban Street Addressing from "General Post Office (GPO) Perth" to "Licensed Post Office (LPO) Quairading".

BACKGROUND

Under the *Local Government Act 1995* the Shire of Quairading is responsible for assigning street numbers to rural and urban residential property addresses. The requirements for street addressing are outlined in the Landgate Addressing Guidelines, and the Australian/New Zealand Standard AS/NZS: 4819 20011 'Geographic information – Rural and Urban Addressing'.

This Policy outlines to staff and the public the procedures for requesting and assigning urban street numbers or rural property numbers, ensuring that information is available to guide both staff and customers should a request for either a change of street address or assigning a rural property number be made to the Shire of Quairading.

STATUTORY ENVIRONMENT

Local Government Act 1995

POLICY IMPLICATIONS

Nil

FINANCIAL IMPLICATIONS

Nil

ALIGNMENT WITH STRATEGIC PRIORITIES

- 1.5 Community:** Support emergency services planning, risk mitigation, response and recovery
- 5.1 Governance & Leadership:** Shire communication is consistent, engaging and responsive
- 5.2 Governance & Leadership:** Forward planning and implementation of plans to determine Strategic Plan and service levels
- 5.3 Governance & Leadership:** Provide informed and transparent decision making that, meets our legal obligations, and the needs of our diverse community
- 5.4 Governance & Leadership:** Implement systems and processes that meet legislative and audit obligations

CONSULTATION

Nil

RISK MANAGEMENT PRIORITIES

This report addresses the following identified Strategic Risk Management Priorities:

Nil.

RISK ASSESSMENT

	Option 1
Financial	N/A
Health	Low <i>Easy identification of and access to property, facilitated by consistent street and rural road addressing will improve the level of safety for the community in cases of emergency.</i>
Reputation	Low <i>Clearly defining to the public in which case it is appropriate to change a property address will reduce confusion and the likelihood of refusal of a request.</i>

Operations	Low <i>Clearly defining to the public in which case it is appropriate to change a property address will reduce the number of inappropriate applications.</i>
Natural Environment	N/A

Likelihood	Consequence				
	Insignificant	Minor	Moderate	Major	Critical
Rare	LOW Accept the risk Routine management	LOW Accept the risk Routine management	LOW Accept the risk Routine management	MEDIUM Specific responsibility and treatment	HIGH Quarterly senior management review
Unlikely	LOW Accept the risk Routine management	LOW Accept the risk Routine management	MEDIUM Specific responsibility and treatment	MEDIUM Specific responsibility and treatment	HIGH Quarterly senior management review
Possible	LOW Accept the risk Routine management	MEDIUM Specific responsibility and treatment	MEDIUM Specific responsibility and treatment	HIGH Quarterly senior management review	HIGH Quarterly senior management review
Likely	MEDIUM Specific responsibility and treatment	MEDIUM Specific responsibility and treatment	HIGH Quarterly senior management review	HIGH Quarterly senior management review	EXTREME Monthly senior management review
Almost certain	MEDIUM Specific responsibility and treatment	MEDIUM Specific responsibility and treatment	HIGH Quarterly senior management review	EXTREME Monthly senior management review	EXTREME Monthly senior management review

COMMENT

Nil

COMMENTS AFFECTING COUNCIL DECISION

Cr Stacey enquired why the Shire of Quairading required its own Policy regarding this, when the rules should be the same across all Western Australian Councils. The EO explained that the main objective of the Policy was to have all relevant information concisely at hand should an enquiry be made to Customer Service staff. Cr Stacey clarified his enquiry in stating that regardless, Council Policies for this matter should be identical. Cr Haythornthwaite asked the EO to research how other Shires handled this.

Urban And Rural Street Addressing Policy



URBAN AND RURAL STREET ADDRESSING POLICY

PURPOSE

To ensure the correct street addressing and clear identification of all properties within the Shire of Quairading and to outline the process and procedure of numbering and renumbering properties within the Shire of Quairading.

OBJECTIVE

The purpose of this Policy is to provide a transparent process for Shire of Quairading Officers as well as the Quairading community to follow with regards to numbering a property or requesting a property number to be changed. This Policy ensures that we are compliant with the *Local Government Act 1995*, Landgate addressing requirements and Australian/New Zealand Standard AS/NZS: 4819 20011 'Geographic information – Rural and Urban addressing'.

POLICY

The Shire of Quairading is responsible for assigning a street number to all land throughout its municipal district to ensure unambiguous and easy identification of each Lot.

That number, when used in conjunction with the other address components such as the road name and locality, needs to uniquely and clearly identify each address site and enable it to be easily located.

The address number is crucial in enabling an address site to be readily locatable by emergency service responders and service delivery providers.

Addresses are assigned using a lodged survey plan supplied to the Shire by Landgate. The addresses assigned by the Shire are shared with Landgate. This ensures Certificate of Title issued by Landgate contain the addresses assigned by Council.

In exceptional circumstances, the Shire may from time to time assign a new street number to a Lot instead of what was previously assigned, including all Lots in a street whether previously numbered or not.

Urban Street Addressing

1. Allocation of Street Address

- a. The main pedestrian access from a road to a building/dwelling (i.e., the front door) determines the correct street address.
- b. Each individual Lot shall be allocated a street number prior to occupation and as early as practicable in the subdivision and development process. An address number may also be assigned to utility sites and reserves.
- c. A street number will be allocated dependent to where the main access point (driveway), letterbox and front door of the property are located.
- d. Street numbering shall be sequential, ranging from lowest to highest from the main access point of the road.
- e. The use of a building name as a street address is not permitted.

2. Identification of Street Address

In accordance with the Landgate guidelines and to meet the requirements of Emergency Service responders and other service providers, properties must:

- a. Have the front door or access to a property clearly identifiable and not obstructed by a garage door or other barrier.

Urban And Rural Street Addressing Policy



- b. The owner or occupier of the subject property is to paint or affix and maintain the current number on a conspicuous and visible place on the front of a building on the property or on the fence, wall, or letterbox adjacent to the road fronting the property within 14 days after the property is first occupied. Numbers are to be clearly displayed and visible and legible from the road.
- c. The house number should be displayed on the letterbox. Letterbox requirements are as follows:
 - i. Must be located at the front boundary access to the property. It must be close to the main access point.
 - ii. The minimum dimensions for each number on a residential letterbox are 75 millimetres high.
 - iii. The minimum dimensions for each number on a non-residential property are 150 millimetres high.

3. Street Addressing for Subdivisions and Developments

The start point for street addressing is to commence from the start point of the subject road. The following methods are to be used to determine the start point:

- a. For roads between two other roads, the start point is to be at the intersection of the road of higher order, in relation to road hierarchy; and
- b. For roads of equal order, the start point is the closest to the Licensed Post Office (LPO) Quairading and
- c. The start point for cul-de-sac is the entrance to the road.

4. Street Addressing Patterns

- a. Street addresses will be consecutive and where a street address has been allocated to a property, then that address must be used.
- b. Odd and even numbers cannot be used on the same side of a road.
- c. Odd numbers will generally be allocated to the left-hand side of a road, and even numbers to the right-hand side, commencing from the start point of the road.
- d. Every Lot will be allocated a street address, including reserves, schools, public utilities, drainage reserves and the like. Usually, one street address will be allocated per Lot, but if foreseen by the Shire and where possible, additional numbers will be set aside to allow for the development potential of the subject Lot.
- e. Where a Lot has two road frontages and the orientation of the dwelling/building has not yet been determined, then the subject property will be allocated a street address for both roads where possible. In accordance with the Australian/New Zealand Standard AS/NZS: 4819 20011, upon completion of the development, a primary address in one frontage shall be allocated. The unused number will be reserved in case of future use.
- f. All street addresses will be sequential, ranging from the lowest to the highest, for example 1, 1A, 2, 2A, 3, 4, 5, 6, 7 and so on.
- g. If a new subdivision is being developed in stages and the first stage occurs in the middle portion of what will eventually be a continuous road of dwellings or buildings, an estimate will be made of the total number of Lots likely to be created along the entire road. This will be aligned with the Residential Design Code provisions for density, and Lot frontage widths for properties.
- h. Street addresses for subdivisions, amalgamations, survey strata and strata subdivisions will be allocated at the clearance/endorsement of documentation stage. In the case of amalgamations, the Shire of Quairading reserves the right to retain any street addresses not used, as it deems appropriate.

Urban And Rural Street Addressing Policy



- i. Single houses and grouped dwellings may be required to share a street number.
- j. If a property containing a retained existing dwelling/building is redeveloped with an additional dwelling/building at the rear and there is only one street number available, the existing dwelling/building will retain the original street number and the new dwelling/buildings will be allocated a suffix to the property street address in accordance with Clause 4.1 below.
- k. If an existing Lot is developed and split adjacent to the road into two or more separate Lots with direct road frontage, the following provisions will be applied:
 - i. where available, whole street numbers will be allocated, and the allocated property numbers will follow the current street numbering pattern; or
 - ii. where there is only one street number available, the Lot closest to the road starting point will retain the original street number and thereafter numbers with suffixes will run sequentially from that point.
- l. Where there is only one street number available, developments will be allocated suffixes, for example 1A, 1B, 1C and 1D. Where more than four (4) suffixes are required, they will be allocated with a numeric prefix, for example 1/17, 2/17, 3/17 and so on.
- m. Where there is a mixed-use development (as per the Residential Design Codes of Western Australia), standard street address rules apply.

Rural Road Numbering

Rural Road Numbering is the style of property addressing used for rural and semi-rural areas in Western Australia.

This numbering style was introduced to aid emergency services when responding to time-critical situations and service providers in locating rural and semi-rural properties more easily and efficiently. Residents are encouraged to apply for a rural road number if you own a rural property that is currently still using a Lot number for addressing i.e. Lot 100 Rural Street.

Rural Road Numbering is a logically established method of numbering a property containing one or more habitable dwellings based on the distance from the start of a road, and usually a Rural Road Numbering plate is erected at the intersection of another road.

1. Allocation of a Rural Road Number

Allocation of a rural road number is carried out in a logical sequence and in accordance with Australian/New Zealand Standard AS/NZS: 4819 20011 'Geographic information – Rural and Urban addressing'. The number is based on a distance from a starting point, usually a road intersection to the property entrance, with odd numbers on the left hand side and even numbers on the right hand side.

The number is equal to the number of metres along the road the property is located and divided by ten. As an example, if a property is 3270 meters from the beginning of the road then your RSA plate will display 327.

Properties that have two entries to separate buildings will be allocated a separate address. This is to ensure that Emergency Service can locate you as quickly as possible. One number may have been allocated for the homestead and another for the shearing shed if they are accessed separately.

2. Location of a Rural Road Numbering plate

A Rural Road Numbering plate must be mounted at the beginning of a relevant driveway of a rural property. The plate can be mounted by star picket, strainer box post or any other fixture, as long as the number can be clearly seen from the side of the road in either direction. If a property has more than 1 entrance, each entrance can have an individual Rural Road Numbering plate assigned.

Urban And Rural Street Addressing Policy



3. Applying for a Rural Road Number

To apply for a Rural Road Number, the property owner can submit a written request to the Shire's Chief Executive Officer by email (shire@quairading.wa.gov.au) or post (i.e. PO Box 38, Quairading WA 6383). Only the property owner can apply for a rural road number.

Request to change a Rural Road Number or Urban Street Address

The Shire accepts change of property address applications in writing (with reasons) addressed to the Shire's Chief Executive Officer via email (shire@quairading.wa.gov.au) or post (i.e. PO Box 38, Quairading WA 6383), however, it must be noted the Shire will only consider changing a property address if there is a valid reason for the request, such as:

- a. Problems with mail or service delivery;
- b. Difficulties locating a property;
- c. If the main access point for an urban property located on a street corner is located on the opposite street frontage to the address currently in use.

Should a change of property address application be successful, the resident can't choose the number allocated to their property. The numbering must still adhere to the numbering standards.

The Shire will not consider changing a property address for the following reasons:

- a. The number is considered "unlucky";
- b. Religious reasons;
- c. To improve the "feng shui" of the property;
- d. Personal preferences;
- e. The number is not good for business;
- f. The property is difficult to sell; or
- g. The number/address "devalues" the property.

An unused street number which has been set aside for a corner Lot will not be re-allocated to the adjoining other property as this number may be required for future purposes.

Council will only consider re-allocating other unused street numbers if the adjacent property cannot be further developed.

If an owner requests a change of address and it is accepted, the Shire will notify Landgate, Australia Post, all key essential service providers (i.e., Water Corporation, Western Power, Telstra etc.), the State and Federal Electoral Commissions, the Police, St John Ambulance and the Department of Fire and Emergency Services to update their property information records.

Any costs associated with a change of street address remain the responsibility of the property owner. This may include:

- a. The replacement and/or relocation of letterboxes;
- b. Cost of new numbers;
- c. Alteration to numbers on buildings;
- d. Replacing/removing painted kerb side numbers; and/or
- e. Notifications to other Government agencies, business and personal contacts.

Costs regarded as consequential will not be covered by the Shire. The Shire excludes any claim for consequential or special losses or any indirect loss to the extent permitted by Law, arising out of any act or omission by or on behalf of the Shire in relation to the addressing of any property. Such damages, losses or costs include, but are not limited to, loss of profits, interest, income, market or utility.

Urban And Rural Street Addressing Policy



GUIDELINES

Landgate Property Street Addressing Guidelines

STATUTORY ENVIRONMENT

Local Government Act 1995

Australian/New Zealand Standard AS/NZS: 4819 20011 'Geographic information – Rural and Urban addressing'.

Record of Review						
Version	Author	Council Adoption	Resolution	Reason for Review	Next Review Date	CEO Signature
01	Nicole Gibbs	30/06/22	200 - 21/22	New Policy	Aug 24	
02	Natalie Ness			Biennial Review	Oct 26	

12.4 School for Pool Program

Responsible Officer Natalie Ness, Chief Executive Officer
Reporting Officer Jen Green, Executive Manager, Economic Development
Attachments Nil
Voting Requirements Simple Majority
Disclosure of Interest Reporting Officer: Financial
 Responsible Officer: Nil

RESOLUTION: OCM 067-24/25

Moved: Cr BR Cowcill
 Seconded: Cr RC Faltyn

That Council approves the "School for Pool" program in collaboration with Quairading District High School and waive the entry fee on weekends for students who attend school for the previous five days during Term 4, 2024 and Term 1, 2025.

FOR: Crs JN Haythornthwaite, TJ Stacey, BR Cowcill, RC Faltyn, EV Gom, JC Hayes and JR Hippisley
AGAINST: Nil

CARRIED 7/0

IN BRIEF

The "School for Pool" initiative aims to incentivize regular school attendance among students at Quairading District High School. Research indicates that consistent school attendance is linked to improved academic performance and personal development. By providing students with free access to the local pool as a reward for their commitment to education, the program seeks to foster a positive school culture and encourage students to prioritize their education.

The Quairading District High School Council has requested that Council collaborate with Quairading District High School on the program.

MATTER FOR CONSIDERATION

The waiving of entry fees to the Quairading Memorial Swimming Pool for students displaying good attendance, in a collaborative project, School for Pool, with Quairading District High School.

BACKGROUND

The "School for Pool" program presents a unique opportunity for Council to actively contribute to the educational and social development of local youth. By incentivizing school attendance, the School and Council can foster a stronger, healthier community.

By providing free access to the local swimming pool on weekends for students who maintain good attendance, the initiative serves as a powerful incentive for academic commitment. This encourages students to prioritize their education, fostering a culture of attendance that can lead to improved academic performance and personal development.

Additionally, the program strengthens the partnership between the local school and Council, fostering a sense of community ownership and involvement in youth development. It allows families to engage in recreational activities, creating opportunities for social interaction and community bonding. The visibility of the pool as a vibrant community resource is enhanced, encouraging families to utilize the facility beyond the program. Ultimately, the "School for Pool" initiative not only supports student attendance but also enriches the community's social fabric and promotes healthier lifestyles for its youth.

Each week, commencing Monday 4th November 2024 during Term 4, 2024 and Term 1, 2025 (during the pool season) teachers will track student attendance, and those who attend school for all five days will be rewarded with a weekend pass to the swimming pool (with the student's name printed on the pass). On Fridays, teachers will distribute the weekend passes to eligible students, emphasizing the importance of commitment and the benefits of participating in the program. To ensure smooth implementation, the school will communicate the program's objectives to students, parents and the broader community.

By having a ticketed system, pool management can keep track of pool attendance and gauge accurate analysis of the program's impact. Quairading District High School has committed to sharing the results of attendance analysis during the program to gauge its overall effectiveness in boost in attendance.

STATUTORY ENVIRONMENT

Local Government Act 1995

POLICY IMPLICATIONS

Nil

FINANCIAL IMPLICATIONS

The waiver of entry fees for students on Saturdays and Sundays is expected to result in a modest decrease in pool revenue. A preliminary estimate indicates a potential loss of \$250-\$500 per week, based on school student numbers. This does not take into account the number of families that will have already purchased a family swimming season pass, and it's unlikely that every single student will access the pool every weekend, nor attend school for the required previous 5 days. So accurate figures are difficult to predict.

The program will run for 6 weeks in Term 4, 2024 (Pool season commencing November 1, 2024) and 9 weeks in 2025 for a total fee waiver of approximately \$3,750 to \$7,500 depending on school student numbers.

The program's long-term benefits, including improved student attendance rates and community engagement, may offset the short-term potential revenue loss. Additionally, the increased visibility of the pool may lead to higher overall usage outside of the program, potentially compensating for the lost revenue during the initiative.

ALIGNMENT WITH STRATEGIC PRIORITIES

- 1.1 Community:** Work collaboratively with local and regional service providers to engage the community as active citizens.
- 1.2 Community:** Provide social and cultural activities for all members of the community
- 5.1 Governance & Leadership:** Shire communication is consistent, engaging and responsive

CONSULTATION

The “School for Pool” program was successfully implemented during the 22/23 swimming pool season, with free entry on the weekend and monitoring student access to the pool during the week. However, the proposed 24/25 program has been streamlined to only include free entry on the weekends, making the management of the program less onerous on teaching staff and pool management.

The program has been discussed at teaching level and endorsed by the Quairading District High School Council at the Term 2, 2024 School Council Meeting.

Feedback from parents, community members, teachers and pool management will continue to be sought throughout the program to gauge wider community sentiment towards the program.

RISK MANAGEMENT PRIORITIES

This report addresses the following identified Strategic Risk Management Priorities:

Nil.

RISK ASSESSMENT

	Option 1
Financial	Low <i>Financial risk will be minimal given the loss of revenue is immaterial and will not impact the Shire’s financial position.</i>
Health	Low Collaboration will encourage increased levels of physical movement and exercise within the student population.
Reputation	Low <i>Ongoing collaboration and partnership with the local District High School is essential and improves reputation across the community.</i>
Operations	Low <i>While the program may increase pool patronage across the weekend, it is unlikely to affect operations.</i>
Natural Environment	Low N/A

	Consequence				
Likelihood	Insignificant	Minor	Moderate	Major	Critical
Rare	LOW Accept the risk Routine management	LOW Accept the risk Routine management	LOW Accept the risk Routine management	MEDIUM Specific responsibility and treatment	HIGH Quarterly senior management review
Unlikely	LOW Accept the risk Routine management	LOW Accept the risk Routine management	MEDIUM Specific responsibility and treatment	MEDIUM Specific responsibility and treatment	HIGH Quarterly senior management review
Possible	LOW Accept the risk Routine management	MEDIUM Specific responsibility and treatment	MEDIUM Specific responsibility and treatment	HIGH Quarterly senior management review	HIGH Quarterly senior management review
Likely	MEDIUM Specific responsibility and treatment	MEDIUM Specific responsibility and treatment	HIGH Quarterly senior management review	HIGH Quarterly senior management review	EXTREME Monthly senior management review
Almost certain	MEDIUM Specific responsibility and treatment	MEDIUM Specific responsibility and treatment	HIGH Quarterly senior management review	EXTREME Monthly senior management review	EXTREME Monthly senior management review

COMMENT

Nil.

COMMENTS

Cr Hippisley enquired whether he, as a member of the School Board, should declare an interest for this item. The EO explained that as the school was not receiving any financial gains from the initiative, a member of the board would not be perceived to have a personal interest in the outcome of Council’s decision.

Cr Hippisley voiced the opinion that the weekly estimate for potential revenue loss seems very high based on his experience of school student attendance at the pool on the weekend. Cr Cowcill asked whether it was possible for Council to receive a report at the end of the pool season that could detail the uptake of the initiative.

12.5 Council committees, advisory groups and delegate appointments

Responsible Officer Natalie Ness, Chief Executive Officer

Reporting Officer Marion Haeusler, Executive Officer

Attachments Nil

Voting Requirements Simple Majority

Disclosure of Interest Reporting Officer: Nil
Responsible Officer: Nil

RESOLUTION: OCM 068-24/25

Moved: Cr JR Hippisley

Seconded: Cr RC Faltyn

That Council

1. For the period ending October 2025 appoint to the Medical Executive Advisory Committee one Proxy Elected Member, Cr Gom.
2. For the period ending October 2025 appoint to the Microgrid Working Group one Proxy Elected Member, Cr Gom.

FOR: Crs JN Haythornthwaite, TJ Stacey, BR Cowcill, RC Faltyn, EV Gom, JC Hayes and JR Hippisley

AGAINST: Nil

CARRIED 7/0

IN BRIEF

This Report refers to Councillor representation on occasional advisory committees, reference committees and working groups established by Council.

- Council’s practice/convention in determining Councillor representation on these groups is: The tenure of a Councillor’s appointment is 2 years, i.e. October 2023 to October 2025, and is guided by Section 5.11 of the Act (unless it is a Ministerial appointment);
- Councillor appointments to these Groups are made by simple majority resolution of Council
- For each Group, a brief explanation of the group’s purpose/role is provided along with details of the meeting frequency to assist Council in determining its representation on the group.

Former Cr Smith’s resignation has left vacancies on the Medical Executive Advisory Committee and the Microgrid Working Group (both Proxy Elected Member). Council are asked to appoint delegates to fill those vacancies.

MATTER FOR CONSIDERATION

As a result of the recent Extraordinary Election, all seats on Council are now again filled. Council should now appoint Councillors into the delegate positions left vacant by former Cr Smith’s resignation.

BACKGROUND

In accordance with the *Local Government Act 1995*, Council can establish committees to assist with its decision-making functions and responsibilities. Following the biennial local government elections, it is practice for Council to appoint members to Council committees.

Council is also requested to call the first meeting of its new committees to:

- enable a Presiding Member to be appointed
- establish meeting dates where necessary for the 2024 Calendar Year
- establish meeting days, times and frequency for 2024.

The *Local Government Act 1995* is silent on the formation of Advisory Groups by local government. As a local government, the Council has an obligation to operate within the parameters of the legislation that governs it.

No changes are necessary to the appointment of members of the Audit & Risk Committee, as Council previously appointed the whole of Council to the Committee.

Medical Executive Advisory Committee

The MEC is established to:

- Oversee and monitor the operation of the Medical Practice Agreement dated the 25th January 2024
- Meet with the Medical Service Provider (Principal GP) in accordance with the Medical Practice Agreement
- Provide feedback to Management regarding the future allocation of resources to the Practice
- Ensure that Community thoughts / feedback is effectively communicated with the Medical Service Provider
- Monitor medical/administrative matters in the Central Wheatbelt Region that may impact on the local Community and the Medical Practice and when necessary, report to Council on any matters.

Vacancies	Members since October 2023	Renumeration	Meeting Frequency
One	Shire President Cr Jo Haythornthwaite and Cr Jonathan Hippisley Cr Peter Smith (Proxy) (now vacant)	Not applicable	Four meetings annually – currently on hold

Microgrid Working Group

The BESS Project is currently on hold as funding was not received from Treasury to progress the project. Ministers are now being lobbied on the issue to garner insight into next steps to secure State funding to continue this project and secure an alternate energy source for Quairading’s future.

A project update will be presented to the Concept Forum once an alternate funding stream is sourced and then the working group will be reinstated.

Vacancies	Members since October 2023	Remuneration	Meeting Frequency
One	Cr Jo Haythornthwaite Cr Jonathan Hippisley Cr Peter Smith (Proxy)(now vacant)	Not applicable	Fortnightly

STATUTORY ENVIRONMENT

Local Government Act 1995

POLICY IMPLICATIONS

Nil

FINANCIAL IMPLICATIONS

Nil

ALIGNMENT WITH STRATEGIC PRIORITIES

- 1.4 Community:** Support local volunteer organisations through initiatives that reduce volunteer fatigue and strengthen their resilience
- 5.1 Governance & Leadership:** Shire communication is consistent, engaging and responsive
- 5.3 Governance & Leadership:** Provide informed and transparent decision making that, meets our legal obligations, and the needs of our diverse community
- 5.4 Governance & Leadership:** Implement systems and processes that meet legislative and audit obligations

CONSULTATION

Nil

RISK MANAGEMENT PRIORITIES

This report addresses the following identified Strategic Risk Management Priorities:

Nil.

RISK ASSESSMENT

	Option 1
Financial	Low <i>No financial implications</i>
Health	Low <i>Nil</i>
Reputation	Low <i>Nil</i>
Operations	Low <i>Committees and Groups already established</i>
Natural Environment	Low <i>Nil</i>

	Consequence				
Likelihood	Insignificant	Minor	Moderate	Major	Critical
Rare	LOW Accept the risk Routine management	LOW Accept the risk Routine management	LOW Accept the risk Routine management	MEDIUM Specific responsibility and treatment	HIGH Quarterly senior management review
Unlikely	LOW Accept the risk Routine management	LOW Accept the risk Routine management	MEDIUM Specific responsibility and treatment	MEDIUM Specific responsibility and treatment	HIGH Quarterly senior management review
Possible	LOW Accept the risk Routine management	MEDIUM Specific responsibility and treatment	MEDIUM Specific responsibility and treatment	HIGH Quarterly senior management review	HIGH Quarterly senior management review
Likely	MEDIUM Specific responsibility and treatment	MEDIUM Specific responsibility and treatment	HIGH Quarterly senior management review	HIGH Quarterly senior management review	EXTREME Monthly senior management review
Almost certain	MEDIUM Specific responsibility and treatment	MEDIUM Specific responsibility and treatment	HIGH Quarterly senior management review	EXTREME Monthly senior management review	EXTREME Monthly senior management review

COMMENT

Nil.

ITEM 13 MATTERS FOR CONSIDERATION – HEALTH & BUILDING





No matters for consideration

ITEM 14 MATTERS FOR CONSIDERATION – WORKS & SERVICES

14.1 Update on Works & Services Programme

Responsible Officer Natalie Ness, Chief Executive Officer

Reporting Officer Sarah Caporn, Executive Manager, Works & Services

Attachments 1. Roads Not Graded, Winter 2023, updated to Oct 2024  
 2. Financial Reporting - Works & Services, October 2024  

Voting Requirements Simple Majority

Disclosure of Interest Reporting Officer: Nil

Responsible Officer: Nil

RESOLUTION: OCM 069-24/25

Moved: Cr JR Hippisley

Seconded: Cr JC Hayes

That Council endorse the current status of the programme for Shire of Quairading Works & Services team to October 2024.

FOR: Crs JN Haythornthwaite, TJ Stacey, BR Cowcill, RC Faltyn, EV Gom, JC Hayes and JR Hippisley

AGAINST: Nil

CARRIED 7/0

IN BRIEF

- The winter maintenance programme is now complete.
- The Depot remains a busy place with machinery repairs and other preparations for the upcoming road construction.
- 2024/25 Capital Works projects are underway at the Pool and Daycare Centre.

MATTER FOR CONSIDERATION

An update of current Works & Services projects is provided below.

PROJECT UPDATES

Construction:

Winter Maintenance: The winter road maintenance programme has now concluded. The EMWS threw everything at completing a maintenance grade on every single kilometre of unsealed road this year and we are pleased to report that we were successful with our goal. This has highlighted that many roads are in dire need of resheeting with the remaining gravel wear layer either sub-standard or missing completely and vehicles are travelling on the subgrade. The EMWS will aim to rectify this in the 2025/26 Roads to Recovery projects. An update on the list of roads not completed in Winter 2023 is provided as Attachment 1 for Council’s reference.

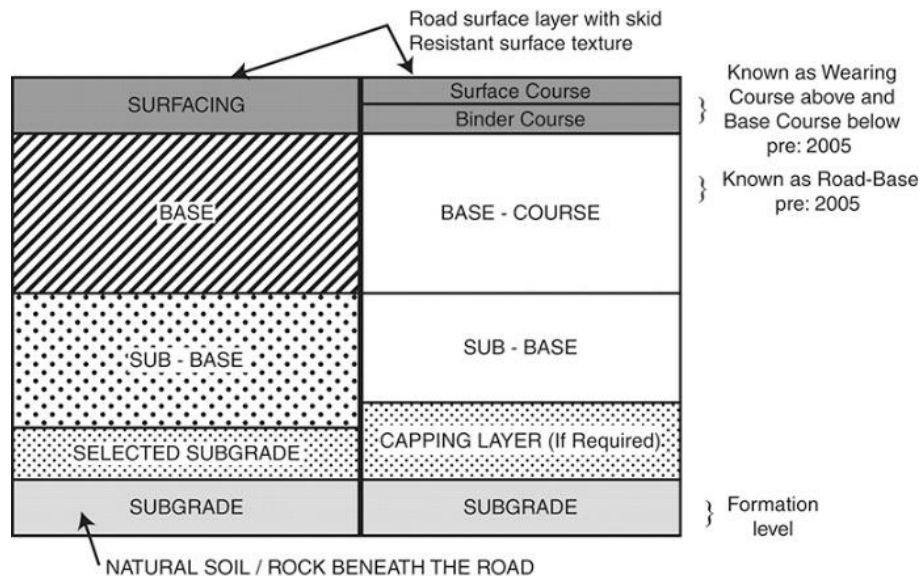

2024/25 projects

Regional Road Group:

The confirmed sections of Regional Roads Group construction are 2.12km on Quairading-Bulyee Road (SLK 7.58 to 9.70) and 2km on the Old Beverley Rd East (SLK 7.12 to 9.12) utilising both RRG and LRCI funding.

The Construction team is scheduled to begin clearing the Old Beverley Road the week commencing 21 October before moving to the Bulyee Road.

The sample analysis results have confirmed that the Shire don’t need to compete a gravel overlay on either the Old Beverley Road no Bulyee Roads which will save time and costs which means funding should be sufficient to make some additional SLK. We need another 0.43km to meet the already widened floodway at SLK 6.69 on Old Beverley Road and are hoping to extend by another 1km of works on the Bulyee Road.

The existing pavement will be strengthened with 1.4% of GP cement by mass and then wet mixed to a depth of 250mm.

The Request for Quotes have now been prepared and circulated via the WALGA Preferred Supplier Panel to secure stabilising and sealing contractors.

Reseals:

No updates to report. Resealing will occur concurrently with the Regional Roads Group sealing works.

Unsealed Roads – Gravel Resheets:

Gravel resheets are planned for Andrews Road (SLK 0.00 – 2.00) and Cubbine Road (SLK 29.42 to 32.00). As mentioned above, sourcing adjacent gravel is going to be a key component to ensuring minimised cartage costs. These will be scheduled after the main construction is completed, likely March/April 2025. It is now likely that the source gravel for the Cubbine Road works will come from Mr V. Hadlow's pit on Hayes Road.

Footpaths: As Councillors are aware, footpaths are a priority area of concern for community members but are the hardest to fund. The entire Executive team will continue to seek suitable grants or any opportunity for external funding sources to implement our planned footpath upgrades. The next area of priority is to upgrade the asphalt path from Parker House / Arthur Kelly Village to the main street precinct on the southern side of Jennaberring Road. Current cost estimates are around \$174,000 which is not currently available within the 2024/25 Budget.

Grounds & Gardens:

Cemetery: The digitising of the Quairading Cemetery records is now complete. We anticipate building a landing page on the Shire's website to direct people through to the Chronicle software. Shire staff will need to input South Caroling and Doodenanning records manually. The Depot Administration Officer has been working through the current list of reservations in a methodical manner to clarify the status of each request. Some plots are still listed as Reserved but contain an interment while others have a faint surname with no supporting paperwork. Staff will now endeavour to reach out to known family members to update the Shire's reservations records. Reservations (or Grant of a Right of Burial as they are more officially known) are available for a nominal fee and valid for a 25-year period.

Sportsgrounds: CAI Fencing is due to commence works on the Cricket Nets and Waste Site the week beginning 28th October. Some more 120L bins have also arrived as part of the Bark Park upgrades to the oval area with additional signage and a water fountain with dog bowl also on the way soon.

Swimming Pool: The hedge and old fencing have now been replaced on the northern boundary with the Caravan Park providing a much more secure edge of the site. Works staff have also been assisting with preparing the pool for the opening of the season including trimming the remaining hedge, repairing tiling on the access steps to Main Pool and procurement of a supplier to modify the access ramps into the pool entry precinct. Prams and less mobile users will be encouraged to use the northern ramp (modified to the correct 1:14 gradient and added handrail) with a step now on the southern side.



Waste Site: Waste site continues to operate well with many positive comments received from residents. Our 2023/24 Annual Return has been completed and accepted by the State Government. Main Roads WA has recently delivered approximately 1500MT of mixed rubble from the Yoting Bridge project to the Quairading Waste Site so this will generate some unexpected income for Council which will be reported in further detail to the November meeting.

Caravan Park: The Park Manager has recently completed Project Management Essentials training to allow for his assistance with the proposed Studio installation. Preparations and training are also underway for a casual caretaker to assist the Shire in covering the Manager’s annual leave during the December/January holiday period. The Caravan Park will be relatively quiet for guests but regular tasks such as irrigation of lawns and cleaning of the communal camp facilities will still need to occur daily.

Parker House: Works staff have recently met with residents and the committee to discuss final plans for the landscaping. The five garden wind spinners have now arrived and will soon be installed for residents to enjoy. The shade sail has also been repaired but will likely need replacing next winter but we’ll see how long it holds together. There are a few plants to replace, some to remove and the final bit of budget to spend. The consensus from residents and their family members is that they would like to explore solar lighting and a front post and rail fence so Shire staff will assist in quoting various options.



L. Example of post and 2-rail fencing

The Groves – The EMWS has begun to scope potential costs and suppliers for an Ablution Block at The Groves site. The initial request includes two ambulant-accessible flushing toilets on a concrete pad with adjacent hand basins, solar lighting and a potable water tap on the exterior for filling cooking pots or washing. There are both modular and buildable kits available and the preferred model will largely be dictated by available funds. The CEO has prepared a grant application, but the outcome will not be known until December 2024.

8 Dall St: Higher neighbour fencing has also been completed at 8 Dall St. The current Super 6 fence was left in place as it was retaining the ground with the neighbouring property at 10 Dall St.

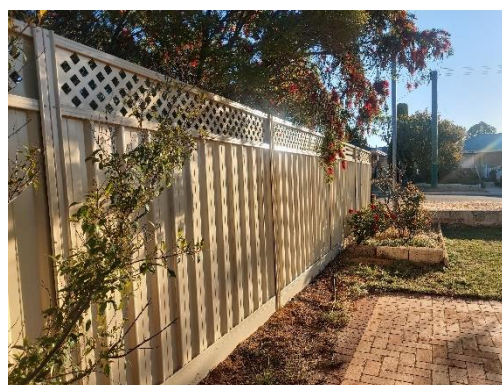

Daycare Centre: Purchase Orders are now in place for the office upgrade at the Daycare Centre (Managers office will be installed into current bag drop area and bag drop hooks moved out to main room) as well as installing a washer into the bathroom area. This includes the cabinetry as well as plumbing and electrical services. The landscaping is also now complete with the installation of an irrigation control box.

Town Hall: The cool room wasn't working prior to Mrs Beryl Stacey's funeral so we appreciate Peter from Woodstock Electrical in Kellberberrin rearranging his schedule to get it up and running again. We have ordered and received extra plates and forks for the Hall so there will be plenty there for the Australia Day event. The tablet in the Bio Box has also been replaced. The reported issue with the microphones was also resolved while K2AV were on site. Someone had entered the rack and turned off those receivers which was frustrating to learn. The carpets and the kitchen are also scheduled for their regular deep clean with Marzocchi Contracting.

Plant Updates: The EMWS anticipates advertising two utes (fmr Q190 and Q661, plates retained by Shire) and the large meeting table in a Disposal of Property process in the next month or so. Items will be advertised for not less than two weeks and well promoted throughout the community. Both utes will have a reserve price based on the trade-in value provided by dealership when we purchased the new EMWS and Supervisor of Gardens Mazda BT50 utes.

The skidsteer has been back to Clark Equipment in Perth for a major service and repair to the hydraulic lines. The Case backhoe that lives at the Tip has also been under repairs for hydraulic lines and we've been hunting a fuel cap and both door handles now that new glass has been installed.

The Depot will be also implementing a new system of pre-start checklists using a heavy-duty Samsung tablet. The iAuditor software will easily lead staff through the required checks and allow for photos to be included in the final PDF report. We anticipate improvement in the completion of pre-starts and picking up of minor maintenance requirements before they turn into major repairs.

Training Updates: The entire Gardens team have recently completed training on the application of chemicals. There has been some confusion on what training modules are actually needed for Local Government officers to be able to use chemicals in their work and some further advice is needed to confirm requirements. This training should be sufficient to allow staff to correctly apply herbicides for weed control in the short term.

Works staff have also undertaken the Bushfire Safety Awareness course so are able to attend and assist on fire grounds should they be needed.

Four new Works staff have completed three days of Basic Worksite Traffic Manager & Traffic Controller training so the Shire can undertake our own traffic management when required. We ran the session in Quairading and officers from the Shire of Cunderdin, Beverley and York were also able to attend.

Still to complete is Chainsaw/Polesaw, First Aid, Fire Warden & Fire Extinguisher.

ENVIRONMENT

Local Government Act 1995

POLICY IMPLICATIONS

Nil

FINANCIAL IMPLICATIONS

The above programmes are currently costed within the 2024/25 Annual Budget with current expenditure as per Attachment 2. Expenditure that currently exceeds the budgeted costs are highlighted in red. Council may also notice that other costs are nearing the forecasted budget. The EMWS is confident to find savings elsewhere to cover these. Council can expect some budget reallocations in future meetings as final project costs become clear.

ALIGNMENT WITH STRATEGIC PRIORITIES

- 3.1 Built Environment:** Safe, efficient and well maintained road and footpath infrastructure
- 3.2 Built Environment:** Parks, gardens and social spaces are safe and encourage active, engaged and healthy lifestyles
- 5.3 Governance & Leadership:** Provide informed and transparent decision making that, meets our legal obligations, and the needs of our diverse community

CONSULTATION

The Works team received a high level of customer requests which are immediately assessed by EMWS and responded to within a timely manner. A new Request Form has been developed for community members to fill in and request assistance from the Works & Services team which provides a greater level of detail than previous forms. The form is available at the Front Counter and via the Shire’s website.

RISK ASSESSMENT

RISK ASSESSMENT	
Financial	Moderate <i>The Works budget is a substantial investment into our town and the Shire’s assets. It needs to be properly allocated and have transparency for community members and ratepayers.</i>
Health	N/A
Reputation	Medium <i>The Works team has strong visibility within the community and are committed to making sure the Shire is a safe and a beautiful place to live and work.</i>
Operations	Medium <i>A well-functioning Works team ensures that Council’s priority tasks and ongoing programme are completed in a timely and value for money method.</i>
Natural Environment	N/A

	Consequence				
Likelihood	Insignificant	Minor	Moderate	Major	Critical
Rare	LOW Accept the risk Routine management	LOW Accept the risk Routine management	LOW Accept the risk Routine management	MEDIUM Specific responsibility and treatment	HIGH Quarterly senior management review
Unlikely	LOW Accept the risk Routine management	LOW Accept the risk Routine management	MEDIUM Specific responsibility and treatment	MEDIUM Specific responsibility and treatment	HIGH Quarterly senior management review
Possible	LOW Accept the risk Routine management	MEDIUM Specific responsibility and treatment	MEDIUM Specific responsibility and treatment	HIGH Quarterly senior management review	HIGH Quarterly senior management review
Likely	MEDIUM Specific responsibility and treatment	MEDIUM Specific responsibility and treatment	HIGH Quarterly senior management review	HIGH Quarterly senior management review	EXTREME Monthly senior management review
Almost certain	MEDIUM Specific responsibility and treatment	MEDIUM Specific responsibility and treatment	HIGH Quarterly senior management review	EXTREME Monthly senior management review	EXTREME Monthly senior management review

COMMENT

Nil.

COMMENTS

Cr Stacey asked when the road speed indicator sign was expected to be installed on the main street. The EMWS answered that installation was imminent. Cr Hippisley asked if at any point during our hire period the sign could be moved to Ashton Street, as trucks were travelling towards the CBH bin at speed. The EMWS replied that the Shire had use of the sign for a period of six weeks and could place it anywhere within that timeframe.

Cr Gom enquired whether there was a possibility to extend the 80km/h zone at the western exit of town to the boundary of the reserve in order to protect wildlife crossing the road. Cr Haythornthwaite referred the question to the EMWS who answered that to Council’s and the community’s continued frustration, as the road in question is under MainRoads jurisdiction and a RAV (Restricted Access Vehicle) route, Council had no power over setting the speed limit, or indeed much else regarding the road.

Roads Not Graded in Winter 2023

Road Name	Length	Date completed in 2024
Black	4.2	26/08
Bond	5.47	22/07
Brighthouse	2.9	17/07
Dall	2.9	07/10
Dangin South	7.2	13/09
Harvey	6.60	16-17/07
Hayes East	5.63	20/09
Haythornthwaite	2.74	11/07
Horsley	5.8	24-25/07
Old Yoting	9.23	26/09
Pannell	4.10	5/06
Robb Lane	4.51	3/08
Shenton	5.15	23/09
Simpson	2.97	30/07
Solomon	15.26	17-18 & 21/10
Solomon South	5.31	<i>gravel top-up required</i> 22/10
Stacey Bus	2.46	22/09
Stones	8.76	29/07
Sunny Vale	3.19	07/10
Wamenusking	13.57	22-24/07
Wamenusking East	7.62	06/08
Yacklin	8.43	10/09
Yoting South	14.42	8-10/10



**2024/25
WORKS & SERVICES**

YTD Actuals includes issued POs

Updated to 21 October 2024

2024/25 - Construction	GL Code	Total Budget	YTD Actual	Variance
RRG – Qdg Corrigin Reseal SLK 4.30 – 6.23	RRG166B	\$ 105,245.00 Carryover PO5036	\$ 68,802.75	\$ 36,442.25
RRG – Bulyee Qdg Rd SLK 7.58 – 9.70	RRG002	\$ 554,765.00	\$ 9,143.72	\$ 545,621.28
RRG – Old Beverley East Rd SLK 9.12 – 8.12	RRG006	\$ 244,673.00	\$ 6,602.60	\$ 238,070.40
LRCI – Old Beverley East Rd SLK 8.12 – 7.12	LRC006	\$ 244,649.00	\$ -	\$ 244,649.00
WSFN – Dangin Mears Rd <i>Development Funds</i>	WSF010D	\$ 62,989.75	\$ 9,976.00	\$ 53,013.75
<i>Total across multiple FY \$132,600</i>				

Roads to Recovery	GL Code	Total Budget	YTD Actual	Variance
Dangin Tce, Dangin <i>280m x 10m wide, 7mm aggregate = 2800m2 x \$7.20 = \$20,160</i>	R2R169	\$ 22,000.00	\$ -	\$ 22,000.00
Walker St <i>800m x 10m wide, 7mm aggregate = 8000m2 x \$7.20 = \$57,600</i>	R2R138	\$ 60,000.00	\$ -	\$ 60,000.00
Qdg Corrigin Rd Reseal SLK 2.93-4.30 Centre line mark 31km	R2R166	\$ 140,000.00 \$ 80,000.00 \$ 60,000.00	\$ - \$ - \$ -	\$ 140,000.00 \$ 80,000.00 \$ 60,000.00
Cubbine Rd, Cubbine SLK 29.42 to 32.00, 2.58km <i>Gravel Resheet, 150mm</i>	R2R005	\$ 83,561.00	\$ -	\$ 83,561.00
Andrews Rd SLK 0.00 to 2.00 <i>Gravel Resheet, 150mm</i>	R2R105	\$ 82,040.50	\$ 6,015.00	\$ 76,025.50
Kellerberrin-Yoting Road SLK 0.00-16.01 <i>Verge Mulch</i>	R2R164	\$ 90,000.00	\$ 74,784.44	\$ 15,215.56
Hayes Road SLK 0.00 – 14.40 <i>Shoulder Grading</i>	R2R015	\$ 70,000.00	\$ 30,960.00	\$ 39,040.00
Punch Road - Drainage SLK <i>Pipes to Culvert Boxes</i>	DC143	\$ 20,000.00	\$ -	\$ 20,000.00

2024/25 BUDGET V ACTUALS - WORKS DEPOT

NB: YTD ACTUALS INCLUDES ISSUED POS

Roads to Recovery	GL Code	Total Budget		Variance
Minchin Road - Drainage SLK 1.00 <i>Pipes to Culvert Boxes</i>	DC063	\$ 20,000.00	\$ -	\$ 20,000.00
Qdg-Corrigin Road - Drainage SLK 9.49 & 10.05 <i>Lids to Timber Culvert Boxes</i>	DC166	\$ 20,000.00	\$ 12,065.60	\$ 7,934.40
Badj Nth Rd – Bridge 4145	BR4145	\$ 20,000.00	\$ 20,000.00	\$ -
Total (target \$627,479)		\$ 627,601.50	\$ 143,825.04	\$ 483,776.46

Roads Jobs	GL Code	Total Budget	YTD Actual	Variance
Road, Bridge, Drainage Maintenance (to end of prior month)	RM000 BM000 DM000	\$ 583,450.00	\$ 430,221.98	\$ 153,228.02
Signs & Traffic Equipment \$25K materials, rest installation	SIGNS	\$ 32,471.00	\$ 6,028.77	\$ 26,442.23
Noxious Weed Control Rural Road Spraying, all 942km 24/25	W13101	\$ 9,896.00	\$ 17,035.08	-\$ 7,139.08
Street Trees Trim from power lines	TREES	\$ 31,664.00	\$ 21,326.27	\$ 10,337.73

Other 24/25 Projects	GL Code	Total Budget	YTD Actual	Variance
CESM, Fire Danger Signs	EM5702	\$ 30,000.00	\$ -	\$ 30,000.00
Bore Field / Community Water Partnership Project	PC11315	\$ 38,661.00	\$ -	\$ 38,661.00
Light Industrial Area #2	TP0000	\$ 50,000.00	\$ 47,211.82	\$ 2,788.18

2024/25 Capital Projects	GL Code	Total Budget	YTD Actual	Variance
Works Depot (racks for Gardens Shed, wash bay)	BC12201	\$ 8,617.00	\$ -	\$ 8,617.00
Parker House (landscaping)	BC8610	\$ 30,594.00	\$ 22,406.77	\$ 8,187.23
Recycling Centre (bay barriers, fencing)	BC10102	\$ 88,376.00	\$ 24,159.73	\$ 64,216.27
Cemetery (repair gazebo)	OC10703	\$ 16,792.00	\$ -	\$ 16,792.00
Swimming Pool (north fence)	BC11201	\$ 28,000.00	\$ 14,545.45	\$ 13,454.55
Swimming Pool (kiosk/entry)	BC11202	\$ 5,000.00	\$ 6,089.43	-\$ 1,089.43
Swimming Pool (plant room, pump) ETA April 2025	BC11205	\$ 50,000.00	\$ -	\$ 50,000.00
Cricket Nets	OC11344	\$ 44,792.00	\$ 31,000.00	\$ 13,792.00
Bark Park infrastructure (signs, water bowl, promo poo bags)	W11301	\$ 9,198.00	\$ 3,261.35	\$ 5,936.65

2024/25 BUDGET V ACTUALS - WORKS DEPOT

NB: YTD ACTUALS INCLUDES ISSUED POS

Works Jobs	GL Code	Total Budget	YTD Actual	Variance
Community Park, Kwirradging Koort (operational)	W11323	\$ 84,366.00	\$ 27,025.28	\$ 57,340.72
Oval & Grounds	W11332	\$ 121,442.00	\$ 23,913.57	\$ 97,528.43
Toapin Weir	W13210	\$ 9,246.00	\$ 419.57	\$ 8,826.43

Building Projects	GL Code	Total Budget	YTD Actual	Variance
Golf Club (bathrooms)	BC11305	\$ 6,000.00	\$ -	\$ 6,000.00
Medical Centre (desks, blinds)	BC7702	\$ 12,500.00	\$ 2,760.00	\$ 9,740.00
Daycare Centre (kitchen, office space, laundry shelves)	BC8301	\$ 20,000.00	\$ 29,846.24	-\$ 9,846.24
14 Reid St (gas hob, splashback)	BC9101	\$ 5,000.00	\$ -	\$ 5,000.00
Unit 1 Gillet St	BC9102	\$ 3,750.00	\$ 197.77	\$ 3,552.23
Unit 2 Gillet St	BC9202	\$ 6,550.00	\$ 197.77	\$ 6,352.23
Unit 3 Gillet St	BC9203	\$ 3,750.00	\$ 197.77	\$ 3,552.23
Unit 4 Gillet St	BC9112	\$ 3,750.00	\$ -	\$ 3,750.00
8 Dall St (garage door, fencing)	BC9104	\$ 33,490.00	\$ 16,000.00	\$ 17,490.00





Plant & Equipment	GL Code	Total Budget	YTD Actual	Variance
EMWS Ute (Q388)	PE12301	\$ 72,000	\$ 68,756.09	\$ 3,244
Tractor, 90HP	PE12304	\$ 90,000	\$ 75,000.00	\$ 15,000
Smooth Drum Roller (proceeds on sale \$80K)	PE12311	\$ 300,000	\$ -	\$ 300,000
Mazda BT50 (Q661) (proceeds on sale \$24K)	PE12313	\$ 65,000	\$ 51,723.62	\$ 13,276
Grader (proceeds on sale \$150K)	PE12314	\$ 400,000	\$ -	\$ 400,000
6 Wheel Tipper (proceeds on sale \$110K)	PE12317	\$ 292,702	\$ 266,898.86	\$ 25,803
Tenant Sweeper (proceeds on sale \$25K)	PE12319	\$ 75,000	\$ -	\$ 75,000
External Plant Repairs	24104110	\$ 76,550	\$ 63,144.90	\$ 13,405

Other PWO Codes	GL Code	Total Budget	YTD Actual	Variance
Works, Training	21403040	\$ 36,499	\$ 56,263.91	-\$ 19,765
Works, Uniforms	21403030	\$ 8,400	\$ -	\$ 8,400
Works, WHS, PPE (incl Tool Box Mtgs)	21403300	\$ 8,539	\$ 6,886.25	\$ 1,653
Works, Minor Assets / Tools	2140386	\$ 33,000	\$ 2,915.74	\$ 30,084
Depot, Building Operations	BO12201	\$ 107,198	\$ 58,748.40	\$ 48,450

14.2 Finalise Procurement, Request for Tender for Road Grader

Responsible Officer Natalie Ness, Chief Executive Officer

Reporting Officer Sarah Caporn, Executive Manager, Works & Services

- Attachments**
1. Request for Tender, Motor Grader - RFT02-24/25 [↓](#) 
 2. Evaluation of Responses RFT02-24/25 [↓](#) 
 3. Quote - Westrac, Caterpillar 140 [↓](#) 
 4. Quote - McIntosh & Son, Case [↓](#) 
 5. Quote - McIntosh & Son, Liugong [↓](#) 

Voting Requirements Simple Majority

Disclosure of Interest Reporting Officer: Nil

Responsible Officer: Nil

RESOLUTION: OCM 070-24/25

Moved: Cr TJ Stacey

Seconded: Cr EV Gom

1. That Council trade a 2014 12M Road Grader and purchase a Caterpillar 140JOY3 Motor Grader from Westrac for a net changeover price of \$259,000 excl GST.

FOR: Crs JN Haythornthwaite, TJ Stacey, BR Cowcill, RC Faltyn, EV Gom, JC Hayes and JR Hippisley

AGAINST: Nil

CARRIED 7/0

IN BRIEF

The Executive Manager of Works and Services (EMWS) prepared a Request for Tender as per Attachment 1.

The document was circulated to a group of suitable suppliers via the WALGA Vendor Panel/eQuote system, closing on Wednesday 2nd October 2024.

EMWS along with the Works Supervisor of Construction and one of our Plant Operators completed an evaluation, assessing price, specifications, timeliness of delivery and quality including warranty.

An Evaluation Assessment is provided at Attachment 2 and quotes are Attachments 3, 4 and 5.

MATTER FOR CONSIDERATION

Finalisation of the Request for Tender 02/2024-25 for a Road Grader.

BACKGROUND

As per the 10-Year Plant Replacement Plan, the oldest of our road graders is due for replacement.

The Shire currently has two Caterpillar graders in the plant fleet. They have proven to be a good make and model for local government requirements with sufficient horsepower, blade widths and a reversing fan needed to maintain gravel roads.

The specifications in the Request for Tender precluded some manufacturers from providing a submission. Our operators are trained and now prefer using two hydrostatic joystick controllers and not the traditional hydraulic levers and steering wheel. The Shire also prefers a powershift automatic transmission which is not a standard feature on many road graders.

STATUTORY ENVIRONMENT

Local Government Act 1995

Local Government (Financial Management) Regulations 1996

POLICY IMPLICATIONS

Purchasing Policy

FINANCIAL IMPLICATIONS

Has an allocation of \$400,000 within the Annual Budget with an estimate of approximately \$150,000 for the trade in vehicle providing a total changeover cost of \$250,000. The preferred supplier has quoted a total changeover cost of \$259,000 excluding GST. This is slightly more than expected but within the 10% material tolerance of a major plant purchase.

ALIGNMENT WITH STRATEGIC PRIORITIES

- 3.1 Built Environment:** Safe, efficient and well maintained road and footpath infrastructure
- 3.2 Built Environment:** Parks, gardens and social spaces are safe and encourage active, engaged and healthy lifestyles
- 3.3 Built Environment:** Improvements to building infrastructure including our sport and recreation facilities, residential and service delivery facilities following considered cost benefit analysis models and venue management plans
- 5.2 Governance & Leadership:** Forward planning and implementation of plans to determine Strategic Plan and service levels
- 5.3 Governance & Leadership:** Provide informed and transparent decision making that, meets our legal obligations, and the needs of our diverse community
- 5.4 Governance & Leadership:** Implement systems and processes that meet legislative and audit obligations

CONSULTATION

Not applicable.

RISK MANAGEMENT PRIORITIES

This report addresses the following identified Strategic Risk Management Priorities:

Lack of routine maintenance of Shire roads creates public safety risk and associated liability issues.

Asset Management Plan is non-compliant due to aging assets and increasing costs.

Financial misconduct by (a) a Shire employee, and (b) an executive/office holder results in financial, legal and/or reputational damage.

RISK ASSESSMENT

Financial	<p>MEDIUM</p> <p><i>Our current grader has mechanical quirks and is in need of replacement. Should Council not proceed with the tender, repairs will be costly, or pricing will only increase in coming years.</i></p>
Health	N/A
Reputation	<p>HIGH</p> <p><i>The most often requested task of the Shire is to grade the roads. A new machine allows us to have capacity to respond to road maintenance needs swiftly and with precision.</i></p>
Operations	<p>MEDIUM</p> <p><i>Not having reliable plant has a major impact on operations. When we are working on funded road programmes, we need competent operators familiar with the machines and to get the work finished in a timely manner and to a high standard.</i></p>
Natural Environment	<p>LOW</p> <p><i>Newer plant has better environmental controls and technology for emission reduction.</i></p>

	Consequence				
Likelihood	Insignificant	Minor	Moderate	Major	Critical
Rare	LOW Accept the risk Routine management	LOW Accept the risk Routine management	LOW Accept the risk Routine management	MEDIUM Specific responsibility and treatment	HIGH Quarterly senior management review
Unlikely	LOW Accept the risk Routine management	LOW Accept the risk Routine management	MEDIUM Specific responsibility and treatment	MEDIUM Specific responsibility and treatment	HIGH Quarterly senior management review
Possible	LOW Accept the risk Routine management	MEDIUM Specific responsibility and treatment	MEDIUM Specific responsibility and treatment	HIGH Quarterly senior management review	HIGH Quarterly senior management review
Likely	MEDIUM Specific responsibility and treatment	MEDIUM Specific responsibility and treatment	HIGH Quarterly senior management review	HIGH Quarterly senior management review	EXTREME Monthly senior management review
Almost certain	MEDIUM Specific responsibility and treatment	MEDIUM Specific responsibility and treatment	HIGH Quarterly senior management review	EXTREME Monthly senior management review	EXTREME Monthly senior management review

COMMENT

Nil

COMMENTS AFFECTING COUNCIL DECISION

Cr Stacey enquired about tender stipulation to include 2 cigarette lighter outlets. The EMWS explained that these were just 12V power outlets and were stipulated as a matter of course. Even though they might come as standard, including them in the tender guarantees they will be part of the machine when delivered.

Cr Stacey further asked after the mentioned 10% material tolerance, as could not locate a mention in the Purchasing Policy. The EMWS responded that this had been explained to her by the EMCS and was not a matter of policy.

TENDER COVERSHEET



TENDER DETAILS	
Tender No.	RFT No.02/2024-25
Tender Title	MOTOR GRADER
Description	The Shire of Quairading requests quotes for the supply of 1 x motor grader.
Allocation within the Budget	\$400,000 (est proceeds of sale \$150,000)
GL Code / Job ID	PE12314
Particulars of the decision to invite Tenders	Council Resolution OCM029-24/25-August 2024 (Adoption of Annual Budget 2024/25)
Tender Deadline Date and Time <i>(Minimum 14 days)</i>	Wednesday 2 nd October
Advertisement Details:	
RFT File Path	T:\23 - PLANT, EQUIPMENT AND STORES\04. TENDERING
WALGA eQuotes / Vendor Panel: VP428703	

Statistics for this Request

Ref: VP428703

SUPPLIER DETAILS	NOTIFIED	DATE FIRST READ	SUPPLIER RESPONDED
1: Hitachi Construction Machinery (Australia) Pty Ltd	Yes	11/Sep/2024 04:25 AM	Responses received
2: Conplant Pty Ltd	Yes	11/Sep/2024 06:44 AM	Declined to respond
3: Kobelco Construction Machinery Australia Pty Limited	Yes	11/Sep/2024 12:31 PM	Declined to respond
4: MCINTOSH & SON W.A.	Yes	11/Sep/2024 08:18 AM	Responses received
5: CONSTRUCTION EQUIPMENT AUSTRALIA	Yes	Not read	Declined to respond
6: Clark Equipment Sales Pty Ltd	Yes	11/Sep/2024 08:47 AM	Declined to respond
7: Kubota Australia	Yes	10/Sep/2024 05:35 PM	Declined to respond
8: Komatsu Australia Pty Ltd	Yes	11/Sep/2024 10:03 AM	Declined to respond
9: Porter Equipment Australia Pty Ltd	Yes	27/Sep/2024 12:43 PM	Declined to respond
10: WesTrac Pty Ltd	Yes	11/Sep/2024 09:31 AM	Responses received
11: C.E.G. Distributions Pty Ltd	Yes	Not read	Declined to respond
12: VERMEER EQUIPMENT OF WA & NT	Yes	Not read	Declined to respond
13: Brooks Equipment	Yes	11/Sep/2024 09:28 AM	None

TENDER COVERSHEET



TENDERS RECEIVED					
Tender Opening Date and Time:	Tenders opened at 8.20 am on 03/10/2024				
Tenders opened in the presence of: <i>(an Executive staff member must be present)</i>	<table border="1"> <tr> <td>Sarah Caporn, EMWS</td> <td rowspan="3">Signature: </td> </tr> <tr> <td>Dean Mastin, Supervisor of Construction</td> </tr> <tr> <td>Tahlia Hardy-Vickers, Plant Operator</td> </tr> </table>	Sarah Caporn, EMWS	Signature: 	Dean Mastin, Supervisor of Construction	Tahlia Hardy-Vickers, Plant Operator
Sarah Caporn, EMWS	Signature: 				
Dean Mastin, Supervisor of Construction					
Tahlia Hardy-Vickers, Plant Operator					
Tenderers:					
1.	WESTRAC				
2.	MCINTOSH & SON, CASE				
3.	MCINTOSH & SON, LIUGONG				
4.	HITACHI – Response was that they didn't have a suitable model available in Aust.				
5.					

COUNCIL RESOLUTION & SUCCESSFUL TENDERER		
Was this decision by Delegated Authority?	Yes	No
Record of Decision		
Council Meeting Date: 31 st October 2024	Resolution No: TBC	

Successful Tenderer	
Value of Successful Tender	

**REQUEST FOR TENDER**

RFT 02/2024-25

REQUEST FOR TENDER – RFT 02/2024-25

The Shire of Quairading is seeking to purchase one (1) Motor Grader with a GVM no greater than 20 tonne.

The following specifications must also be included:

- Engine power of above 215HP/160KW minimum
- GVM no greater than 20T with all implements
- Hour meter
- Turbo timer
- 2x sets of keys
- Power-shift automatic transmission with direct drive
- Air-conditioned cabin with ROPS/FOPS
- Darkest legal tint on windows and doors
- 9kg fire extinguisher ABE powder installed on inside of cab
- 2x 12V cigarette outlet ports
- Radio with iPod and Bluetooth connectivity
- Air compressor with easily accessible air connection point, fittings and hoses for filling up/letting down tyres
- 2x emergency stops. One inside the cab within arms reach for operator, one on outside of machine where possible
- Tow points installed at front and back of machine rated for at least 4 tonnes. Double tongue tow point with pin at the rear. 2x Tow hooks at the front under push block.
- Work lights and driving lights to have metal mesh around them for protection from rocks.
- Work lights on gooseneck and at bottom of cab
- Heavy duty lockable battery isolation switch
- Neutral safety start switch
- Reversing alarm and camera with colour monitor in cabin
- Rear rippers x5 and rear scarifiers x9
- 14ft mouldboard
- Slope meter installed
- Dual joystick control for steering and implements with advanced joystick controls
- Transmission and belly guards
- Front push block
- All works lights to be LED
- Air suspension seat
- Reversing fan
- Dual element air filters
- Blade controls to include blade float position
- Cruise control

**REQUEST FOR TENDER**

RFT 02/2024-25

- Safety lock for articulation area
- Differential locks
- Vandal proof locks on all doors, fill up points and engine bay
- Information and pricing on extended warranty and service arrangements
- Must suit DOT specifications to be registered for on road use or registered prior to purchase
- 1x LED beacon (Narva Pulse LED Strobe Part No. 85246A) to be installed on top of the cab of the grader in an easily viewable position from the front and rear of the grader prior to delivery with a control switch (illuminated 'Beacon' rocker switch) to be in an easily accessible and viewable location for driver. Lights shall not be drilled into the roof of the cab of the roller but must retain the structural and waterproof integrity of the roof.
- 80 channel two-way radio installed within easy accessible location (not more than arm lengths from the seated position) for the driver.
- Heavy duty canvas seat covers and heavy duty rubber floor mats in the cab.
- Price to be inclusive of delivery to Shire of Quairading depot with Handover of new vehicle provided by the successful supplier.
- Suppliers should provide an indication of stock availability and the timeframe for when a new purchase could be delivered to Quairading.
- The delivery of the vehicle without any of the items as outlined within the specifications above (or installed to the required specifications) will be sent back to the supplier at their cost (and redelivery of the amended vehicle). The cost of all remedial works to meet the required specifications as outlined above shall be entirely at the suppliers cost. In the case of a trade in vehicle with this quote, the trade in vehicle shall be retained (without cost penalty/reduction due to having to remedy the works for the new vehicle by the supplier) until such time as the new vehicle is delivered to the Shire of Quairading (depot) by the supplier.
- The supplier shall be deemed to have made themselves fully aware of the specifications of the new vehicle and trade-in vehicles. Relying on details provided by the Shire representative's either verbally or by correspondence shall not hold the Shire (or the representative) responsible for those details disclosed/provided.
- Canvassing of Shire Councillors shall instantly disqualify the supplier's submission.
- The trade-in vehicles are to be considered as-is-where-is and once traded is entirely at the supplier's consideration (no further correspondence/consideration shall be entered in to with the Shire of Quairading) once traded/purchased.
- The Shire may choose to not accept any tenders entirely at their own discretion.
- The Shire may choose to not accept the lowest tender entirely at their own discretion.



REQUEST FOR TENDER

RFT 02/2024-25

DETAILS OF TRADE VEHICLE

The Shire will potentially be disposing of one Caterpillar 12M grader with a 14ft mouldboard as part of this procurement and a trade-in price should be provided by the successful bidder. Details of the trade vehicles are below. An in-person inspection of the trade-in vehicles at the Shire’s Depot is highly encouraged. Any further enquiries should be directed to the Shire’s Executive Manager of Works and Services, Sarah Caporn on 0427 451 001 or sarah.caporn@quairading.wa.gov.au.

LICENCE PLATE	Q240 <i>(will be retained by Shire with new plates issued)</i>
MAKE	CATERPILLAR
MODEL	12M
BODY TYPE	GRADER
YEAR OF MANUFACTURE	2014
COLOUR	YELLOW
PRIMARY FUEL	DIESEL
TRANSMISSION TYPE	AUTOMATIC
TARE	19000
VIN	CAT0012MCB9200277
ENGINE NUMBER	KHX60657



Supply Of New Grader RFQ 2024/25 - 01

Populate Fields
Formulas
Set as per RFQ

TENDERER	Total Cost (ex GST)	Warranty		Specification		Price			TOTAL weighted score	RANK
		Warranty Score (0-10)	Warranty Weighted Score	Specification Score (0-10)	Specification Weighted Score	60%				
						15%	25%	Price Ratio		
Price Ratio Score (0-5)	Price Score (0-5)	Total Price Score								
WESTRAC CAT 140	\$452,000.00	10.0	15.0	10.0	25.0	4.01	5.00	54.0	94.0	1
MCINTOSH&SON LIUGONG 4230D	\$362,300.00	5.0	7.5	2.0	5.0	5.00	3.00	48.0	60.5	3
MCINTOSH&SON CASE 865B	\$424,000.00	6.0	9.0	3.0	7.5	4.27	3.00	43.6	60.1	2

SCORE PANEL	Score (0-10)
Exceeds requirements, or the evaluation panel is very confident that the supplier has more than the necessary capability	10 points
Meets the requirement and exceeds in some aspects - or the evaluation panel is quite confident that the supplier has more than the necessary capability	8-9 points
Meets the requirement and no more – solution 'complies'	6-7 points
Does not meet the requirement, but may be adaptable or made acceptable - or the evaluation panel is somewhat confident that the supplier has the necessary capability – partially complies	4-5 points
Does not meet the requirement except for a few aspects or the evaluation panel is not very confident that the supplier has the necessary capability	2-3 point
Does not meet the requirement at all or no response to this criteria or the evaluation panel has no confidence that the supplier has the necessary capability - where a "No" is given where a "Yes" was expected or the solution "Does Not Comply"	0-1 points

Price Value for	Score (/5)	Definition of the
5 points		Outcomes in terms of efficiency and effectiveness greatly exceeds price
4 points		Outcomes in terms of efficiency and effectiveness exceeds price
3 points		Outcomes in terms of efficiency and effectiveness are expected or good for price
2 points		Outcomes in terms of efficiency and effectiveness are fair for price
1 point		Outcomes in terms of efficiency and effectiveness are low for price
0 points		Outcomes in terms of efficiency and effectiveness are very low for price

CATERPILLAR 140 GRADER

PREPARED FOR QUAIRADING SHIRE COUNCIL ABN: 24 187 484 077



Quote Type	New Sale - Single Currency	Customer No.	790210
Quote No.	150409-01	Prepared For	Sarah Caporn
Stock No.		Email Address	sarah.caporn@quairading.wa.gov.au
Serial No.		Phone Number	08 9645 2412
Document Date	19/09/2024	Company Address	P O BOX 38 QUAIRADING WA 6383
Prepared By	Slater, Brian	Site Address	

*Image (if present) may include accessories or optional attachments not included in this quotation.

Dear Sarah

WesTrac would like to thank you for the opportunity to submit pricing for your equipment enquiry. WesTrac is one of the world's leading Caterpillar dealers, specialists in the supply and maintenance of Caterpillar earth moving equipment to the mining, construction, forestry, agriculture, and transport industries in Western Australia, New South Wales and the ACT. With our extensive range of products, unmatched service network and innovative technology solutions, WesTrac offer our customers a whole of life management solution designed to make owning and operating equipment as easy, profitable and safe as possible.

WesTrac's mission is to be our customers first choice, in the provision of their equipment solutions; we strive towards maximising our customers success. We offer equipment management solutions for all stages of your equipment's lifecycle; from machine selection and purchase, finance, repair and maintenance, fleet management, disposal or resale, you can be sure WesTrac offers the solutions, service and support you need.

In consideration of the pricing provided, we would ask you to give important consideration to the following:

- a) Uptime Vs. Downtime
- b) After Sales Support
- c) Reliability
- d) Performance
- e) Resale Value

Experience has shown that for more than 85 years customers throughout Western Australia have received unparalleled value for money from the ownership of Caterpillar products and after sales support from the Caterpillar Dealer network.

WesTrac is committed to excellence in all areas of the business and are focused on long term customer relationships. WesTrac is dedicated to customer service, safety, quality and our environment.

Once again, WesTrac would like to thank you for your consideration in allowing us the opportunity to submit pricing for the below product/s.

Should you require any further details, we would be happy to offer any further assistance

Sincerely

Brian Slater | WesTrac Pty Ltd |
Equipment Sales Representative | Marketing
Caterpillar Certified Sales Professional
t: (08) 9377-9427 | f: (08) 9379-4218 | m: 0427 191 121 | i: www.westrac.com.au

EQUIPMENT SPECIFICATIONS

Description	
Caterpillar 140JOY3 MOTOR GRADER	
Includes the following specifications	
POWERTRAIN	
Air cleaner, dual stage dry type radial seal with service indicator through messenger and automatic dust ejector	and idle control.
Air-to-air after cooler (ATAAC)	Fuel-water separator
Belt, serpentine, automatic tensioner	Muffler, under hood
Brakes, oil disc, four-wheel, hydraulic	Parking brake, multi-disc, sealed and oil cooled
Demand fan, hydraulic	Priming pump, fuel
Differential, lock/unlock, AUTO	Rear axle, modular
Drain, engine oil, ecology	Sediment drain, fuel tank
Electronic over speed protection	Transmission, 8 speed forward and 6 speed reverse, power shift, direct drive
Engine:	
-C7 with ACERT technology, diesel, with automatic engine derate	VHP Plus (Variable Horsepower Plus) EIS (Engine Idle Shutdown)
ELECTRICAL	
Alarm, back-up	Grade control ready (Cab harness, software, electrical hydraulic valves, bosses and brackets)
Alternator, 80 ampere, sealed	
Batteries, maintenance free, heavy duty, 1125 CCA	Lights, reversing
Breaker panel, ground accessible	Lights, roading, roof-mounted
Cab harness and electrical hydraulic valves	Lights, stop and tail, LED
Electrical system, 24V	Product link ready
	Starter, electric
OPERATOR ENVIRONMENT	
Accelerator	centershift, front wheel lean and articulation and steering)
Air conditioning with heater	Joystick hydraulic power steering
Arm and wrist rest, adjustable	Ladders, cab, left and right side
Articulation, automatic return to center	Lights, night time cab
Power port	Messenger operator information system
Centershift pin indicator	Meter, hour, digital
Coat hook	Mirror, inside rearview, wide angle
Cupholder	Power Port, 12V
Display, digital speed and gear	Radio Ready, Entertainment
Doors, left and right side with wiper	ROPS cab, sound suppressed 70dB(A)
Gauge, machine level	ISO 6394
Gauges (analog) inside the cab:	
-Fuel, articulation, engine coolant temp, engine RPM, and hydraulic oil temp	Seat, cloth-covered, comfort suspension
Joystick, adjustable armrests	Seat belt, retractable 76.2mm (3")
Joystick gear selection	Storage area for cooler/lunchbox
Joystick hydraulic controls (right/left blade lift with float position, blade sideshift and tip, circle drive,	Throttle control, electronic
	Windows laminated glass:
	-Fixed front with intermittent wiper
	-Side and rear (3)
	Cab storage
TECHNOLOGY PRODUCTS	

RADIOS	PRODUCT LINK
Authorization varies by country, please contact your Cat marketing representative with questions or click on the link below:	Availability varies by country, please contact your Cat marketing representative with questions or click on the link below:
https://dealer.cat.com/en/products/technology.html	https://dealer.cat.com/pl/certification
TIRES, RIMS, AND WHEELS	
A partial allowance for tires on 254mm x 609.6mm (10" x 24") multi piece	rims is included in the base machine price and weight.
FLUIDS	
Antifreeze	Extended life coolant to -35C/-30F
OTHER STANDARD EQUIPMENT	
Accumulators, brake, dual certified	Ground level fueling
Anti-glare paint	Hammer (emergency exit)
Bumper, rear, integrated with hitch	Horn, electric
CD ROM parts book	Hydraulic lines for base functions
Clutch, circle drive slip	Lockout, hydraulic implement (for roading and servicing)
Cutting edges, 152mm x 16mm (6" x 5/8") curved DH-2 steel, 19mm mounting bolts (3/4")	Moldboard, 3658mm x 610mm x 22mm (12' x 24" x 7/8")
Doors, 3 engine compartment, (two left hand, one right hand,) locking	Mounting, cab roof accessories
Drawbar, 6 shoe with replaceable wear strips	Pump, hydraulic, high capacity (98cc/6cu in)
Electrical hydraulic valves, base 8	Radiator, cleanout access
Endbits, 16mm (5/8") DH-2 steel, 19mm(3/4") mounting bolts	Secondary steering
Fluid check, ground level	Serviceability, LH side
Frame, articulated with safety lock	SOS ports, engine, hydraulic, transmission, coolant, fuel
Fuel tank, 416 liters (110 gallon)	Tandem walkway/guards
Ground level engine shutdown	Tool box

FACTORY FITTED EQUIPMENT

Description	
577-1376 140 14A MOTOR GRADER X SLOPE	365-5539 BASE + 1 (RIP)
0P-2265 ROLL ON-ROLL OFF	366-2459 GUARD, TRANSMISSION
0P-2633 RUST PREVENT. FOR HOSE COUPL.	367-6905 GUARD, AXLE HOSE
4K-3330 SHANKS/TEETH, RIPPER/SCARIFIER	374-4558 LIGHTS, WORKING, PLUS, HALOGEN
246-6705 DRAIN, GRAVITY, ENGINE OIL	377-1602 SOUND SUPPRESSION (BOTTOM)
248-6925 TRANSMISSION, AUTOSHIFT	382-6931 FUEL TANK, STANDARD
250-3071 PUSH PLATE, COUNTERWEIGHT	391-4396 CAMERA, REAR VISION
252-0775 TIRES, 17.5R25 BS VKT * D2A MP	421-7810 LIGHTS, ROADING, HALOGEN
253-2724 ALTERNATOR, 150 AMP (AC)	426-1255 AUSTRALIAN PRESS VESSEL REG
261-0610 COMPRESSOR/TANK, AIR	435-2072 CONTROL,AUTO ARTICULATION-FULL
308-6276 TOWING GROUP, 45 MM PIN	447-0898 COOLANT, 50/50, -35C (-31F)
308-9370 HEADLIGHTS,FRONT, LOW, HALOGEN	458-8701 JOYSTICK CONTROLS, ADVANCED
323-6970 GUARD GP, HITCH	462-6393 GRADE CONTROL X SLOPE 2D grade control Allows the operator to manually control one end of the blade to match the curb or crown while automatically maintaining the desired slope of the blade. This system is used to maintain the crown of a gravel road or the shoulder of a road. Provides cab switches, software, harness, sensors and mounting
349-3047 MOLDBOARD, 4.3M BASIC	586-7488 AUSTRALIAN ARRANGEMENT Includes: - Converter for Communications - Premium 12V AM/FM radio with Bluetooth technology, USB port and 3.5 mm AUX input - Film Tie Down - Marker Lights - Mirror, Inside Flat - Mirror, Outside Mounted Convex - Mounting, Warning Beacon Cab, Guarded - Plus Cab - Product Link, PLE641 - Registration Plate Mounting, Front - Registration Plate Mounting, Rear - Shade, Sun, Rear - Tie Down Frame
349-3051 WEATHER, STANDARD	393-6129 CAT MSG ENGLISH, ISO DECALS
354-8706 YEAR OF MANUFACTURE PLATE	421-8926 SERIALIZED TECHNICAL MEDIA KIT
364-1989 INSTALLATION ARR, BOX	0P-2918 STORAGE PROTECTION
305-2927 LINES,STANDARD W/O ACCUMULATOR	324-0889 RIPPER/SCARIFIER

LOCALLY SOURCED ITEMS

Description	
140JOY3 W112172 SUPPLY & INSTALL DISCONNECT SWITCH BATTERY	140JOY3 W118738 SUPPLY & INSTALL FIRE EXTINGUISHER 2.5KG
140JOY3 W112167 SUPPLY & INSTALL FIRE	140JOY3 W120338 SUPPLY & INSTALL LIGHT(S)



EXTINGUISHER 9KG	GUARD FRONT
140JOY3 W112184 SUPPLY & INSTALL WINDOW TINTING	140JOY3 W112178 SUPPLY & INSTALL SEAT COVER CANVAS
140JOY3 W112181 SUPPLY & INSTALL 2-WAY RADIO	140JOY3 W112180 SUPPLY & INSTALL SIGNWRITING
140JOY3 W112156 SUPPLY & INSTALL BEACON/STROBE LIGHT BOTH SIDES	140JOY3 W118585 SUPPLY HAND TOOL GROUP
140JOY3 FULL FUEL ADD FUEL	140JOY3 CAT MANUALS SUPPLY PROD SUPPORT LITERATURE SET (ALL)
140JOY3 W118739 INSTALL WHEEL & TIRE SUPPLY	5P8500 SUPPLY 4 X CAT KEYS
140JOY3 W118921 SUPPLY & INSTALL AIR OUTLET KIT	140 SUPPLY & INSTALL LIGHT GUARDS ON ALL FWD FACING LIGHTS
140JOY3 W112163 SUPPLY & INSTALL EMERGENCY STOP SWITCH	9U-6539 SUPPLY SOCKET FOR WHEEL NUTS
140JOY3 W112162 SUPPLY & INSTALL ENGINE SHUTOFF	9U-6532 SUPPLY SOCKET FOR CUTTING EDGES
140JOY3 W133001 SUPPLY & INSTALL FAN REVERSIBLE FAN	140 12 MONTHS CONCESSIONAL LICENCE

TRADE IN DETAILS

Model	Make	Year	Serial No.	Trade Value
12M	CATERPILLAR	2014	CAT0012MCB9200277	\$193,000.00
Total excluding GST				\$193,000.00

PRICING SUMMARY

Selling Price Excluding GST	\$452,000.00
GST (10%)	\$45,200.00
Selling Price Including GST	\$497,200.00
Less Trade Allowance	(\$193,000.00)
GST (10%) On Trade in	(\$19,300.00)
Trade Price Including GST	(\$212,300.00)
Net Changeover Price Including GST	\$284,900.00

WesTrac would like to offer a no-trade discount of \$10,000+gst

PAYMENT TERMS

21 Days from Date of Invoice.

DELIVERY

Ex Perth Airport Precinct, Reid Road, Kewdale to Quairading
 Subject to prior sale and events of force majeure which will delay delivery and are beyond the control of WesTrac Pty Ltd.



WARRANTY

60 MONTHS / 7000 HOURS POWERTRAIN, HYDRAULICS & TECHNOLOGY

Any attachment that, you the client, elect to fit to this new Caterpillar machine, which is not a genuine Caterpillar attachment and has not been approved by WesTrac Pty Ltd may void the machine warranty should it be determined by Caterpillar and/or WesTrac Pty Ltd that any failure on the machine is caused by fitting such an attachment I.E. Non Genuine Attachments are not covered by Caterpillar Warranty.

CAT FINANCE

To apply for Cat Finance, please visit the [Caterpillar Finance Online Application](#)

Caterpillar Financial Australia Limited is proudly the dedicated financiers for WesTrac Pty Ltd and is a wholly owned subsidiary of Caterpillar Inc.

Caterpillar Financial Australia Limited can tailor a financial services package to suit your business/cash flow needs and through their team of dedicated relationship managers, ensure that the overall Caterpillar purchase experience is a memorable one.

SAFETY AND CONTACT INFORMATION

LINKS	
WA Towing Safety	https://www.wa.gov.au/organisation/road-safety-commission/towing
NSW Towing Safety	https://www.nsw.gov.au/topics/roads-safety-and-rules/vehicle-safety-and-compliance/towing-a-caravan
Operation and Maintenance Safety	https://www.cat.com/en_AU/support/safety.html
WesTrac Locations	https://www.westrac.com.au/locations
WesTrac Training Institute	https://www.westrac.com.au/training

TRAINING INFORMATION

The WesTrac Institute is a Registered Training Organisation (RTO). The Institute provides operator and maintenance training to WesTrac's customers.

Training may be provisioned in the equipment purchase or it can be booked using the link in the Contact Information of this quote.

Please note - training provisions may be subject to expiry dates.

FITFLEET® ESSENTIALS

FitFleet® Essentials is a standard inclusion with all new and used machine purchases. You'll be on Essentials for the length of the machine's applicable warranty period.

FitFleet® Essentials is WesTrac's standard customer value agreements which includes:

- a) Data driven insights into overall health and utilisation of your machine, to allow us to detect problems early and reduce downtime
- b) Alerts to when services are due, providing increased visibility of servicing and maintenance costs
- c) Tools to quickly and easily organise the delivery of genuine CAT parts and;
- d) Streamlined access to book expert technicians to perform your servicing needs

FitFleet® does not alter the Caterpillar warranty applicable to the equipment and is otherwise supplied subject to WesTrac's Terms and Conditions of Software Licence and Services Agreement and WesTrac's Terms and Conditions for the Sales of Machines, Parts and Services by WesTrac (excluding Rentals) available at <https://www.westrac.com.au/en/terms>

For further information about the FitFleet® offering, please visit: <https://www.westrac.com.au/services/FitFleet>

To opt **out** of the FitFleet® Essentials agreement, please sign here:



Caterpillar® Digital Authorisation

Your machine telematics data is a valuable resource that can help you track your machine's location, utilisation, and servicing requirements. Telematics data is also required to ensure you enjoy all the benefits included in your FitFleet® Customer Value Agreement.

Before we can subscribe your machine to report telematics data, yourself or an approved person within your company must complete Caterpillar Digital Authorisation.

In the form below, please provide the contact details of the appropriate person from your company who can complete this authorisation so further instructions can be sent to them.

Caterpillar Digital Authorisation Contact for Company:

First Name: _____

Surname: _____

Email Address: _____

If you do not complete this authorisation, you'll be receiving further communication from Caterpillar in the coming weeks.



OFFER AND ACCEPTANCE

If the customer specified below ("Customer") wishes to purchase the equipment detailed in this quotation, an authorised representative of the customer must sign this document. The authorised representative's signature constitutes an offer by the Customer to purchase the equipment from WesTrac Pty Ltd ("WesTrac") on the conditions set out in this quotation and WesTrac's Terms and Conditions for the Sale of Goods and Services by WesTrac available at westrac.com.au/terms. WesTrac may accept or reject the Customer's offer to purchase in its discretion.

The person signing below on behalf of the Customer represents and warrants that:

1. They have read and understood WesTrac's Terms and Conditions for the Sale of Goods and Services by WesTrac available at westrac.com.au/terms on the date of the offer. They agree, on behalf of the Customer, to be bound by WesTrac's Terms and Conditions for the Sale of Goods and Services by WesTrac available at westrac.com.au/terms. The information provided in connection with this quotation is true and correct. They are duly authorised by the Customer to enter into a contract for the purchase of the equipment on the terms set out in this quotation.

QUAIRADING SHIRE COUNCIL ABN: 24 187 484 077		ACCEPTED BY WESTRAC PTY LTD:	
CUSTOMER NAME		QUOTE NO.	150409-01
CUSTOMER POSITION		WESTRAC AUTHORISED NAME	
CUSTOMER SIGNATURE		AUTHORISED SIGNATURE	
DATE SIGNED		DATE SIGNED	

TERMS AND CONDITIONS

westrac.com.au/terms

CONDITIONS OF SALE

- a. This quotation is valid for a period of fourteen (14) days from the date of the quote. Your offer to purchase the goods pursuant to the quotation must be made within this period.



M^cINTOSH & SON



Case 865B Series 2 Motor Grader QUOTATION

For: Shire of Quairading
Date: 30/9/2024
Attention: Sarah Caporn

By: McIntosh & Son
547 Great Eastern Hwy, Redcliffe, WA
From: Richard Gainsford
Contact: 0438 383 517
R.Gainsford@mcsn.com.au



MCINTOSH GROUP

LEADING AUSTRALIAN MACHINERY GROUP

For more than 60 years, the McIntosh Group has set the benchmark in equipment management solutions, providing unrivalled support in the agricultural, construction and grounds care machinery industries.

Having grown to employ over 600 people Australia wide, our decision makers remain in the frontline – ensuring we deliver and nurture our service-first culture.

Our aim is to build a continuously improving stable of products and services which will help our customers achieve their objectives. In turn, this will drive our business and create opportunities for employee growth, resulting in recognition both as an industry employer and an equipment supplier of choice.

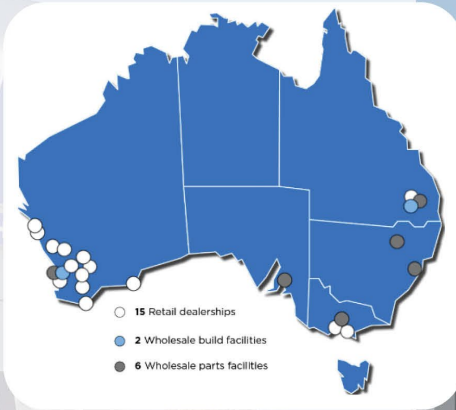

MCINTOSH & SON

Since 1955, McIntosh & Son has been a leading Australian dealership group specialising in agricultural, construction and grounds care machinery with 12 locations located across WA and QLD.

McIntosh & Son is committed to providing customers with comprehensive and exceptional service, and as a result, has developed an enviable reputation as a trusted, respected and reputable machinery dealership.

PURCHER INTERNATIONAL

Purcher International has been a leading supplier of farm machinery and transport equipment to the Midwest region of Western Australia since 1967.

From its dealership in Geraldton, Purcher International supports leading brands including Case IH, Freightliner, Mercedes-Benz Trucks and Fuso.

CASE VIC

Case Vic is a construction machinery retail and rental dealership business.

Servicing Victoria from 2 strategic locations in Dandenong and Truganina, Case Vic has provided the construction industry with sales, parts, product support and rental equipment since 2000.

MCINTOSH DISTRIBUTION

Established in 1993, McIntosh Distribution is an Australian machinery importer and wholesaler with an extensive 140+ dealer network serviced by build facilities and parts depots across Australia.

With a focus on providing excellent customer service, McIntosh Distribution aims to provide farmers, growers and dealerships with industry-leading equipment, parts, service and after-sales support.

MCINTOSH CE

McIntosh CE began in 2021, as McIntosh Group were appointed Australian distributors for Case Construction Equipment.

Responsible for all aspects of Case Construction Equipment across Australia, McIntosh CE supports their dealer network with sales, marketing, product support and parts.

MCINTOSH TRAINING ACADEMY

McIntosh & Son has invested in the future education of our industry by becoming a Registered Training Organisation – McIntosh Training Academy – and developing an in-house apprenticeship program where students can benefit from a dynamic learning environment in our world-class facilities.



McINTOSH & SON PERTH



McINTOSH & SON



Our pursuit of excellence and continuous improvement has resulted in us being the supplier of choice for leading national and international products.

McIntosh & Son are dealers for over 100 machinery brands, including;



PARTS

Our parts department is staffed by experienced and skilled personnel so you receive professional service and advice.

We also stock a range of genuine and factory-direct parts including:



WORKSHOP & FIELD SERVICE

Our service department has a comprehensive team of technicians, auto-electricians, fabricators and apprentices, all committed to delivering the best service.

We offer all aspects of servicing, repairs, maintenance, electrical and hydraulic repairs, machinery inspection and air-conditioning, designed to keep your machinery in optimal condition.



Page | 4

Quote No.:RG0745

Revision No.: 01

Quotation

30th September 2024

Dear Sarah Caporn,

We thank you for the opportunity to present McIntosh & Son and our proposal for the equipment listed overleaf.

Our primary goal is to promote, sell and support the products we represent and to provide equipment supply and service solutions to customers wanting more flexibility and innovation.

Our growth and diversification into new areas has continued to strengthen the company, which operates through a talented and cohesive management team and dedicated staff. We continually strive to provide superior service and offer a quality product range to accommodate the needs of our customers.

The McIntosh & Son sales team has a wealth of experience and knowledge across our machinery range. Our service team aim to deliver the best assistance to keep your construction, grounds care and agricultural machinery in optimal condition. We stock a wide range of parts and accessories, and our parts staff can assist with ensuring you get the right parts when you need them.

Should you require finance, our relationship with PTR Asset Finance can help with a wide range of financial services that are customised and flexible. They have the expertise to deal with your next equipment purchase, and pride themselves on keeping up with industry movements to provide competitive solutions for your business. They can be contacted at their offices in Osborne Park on 08 9322 1229.

We hope that the quotation provided overleaf meets with your approval, and we are always available for further discussion.

Yours sincerely,

A handwritten signature in black ink, appearing to read 'Richard Gainsford'.

Richard Gainsford
Construction Sales
McIntosh & Son
0438 383 517



McIntosh Holdings Pty Ltd ABN 28 008 675 876 T/AS McIntosh & Son
547 Great Eastern Highway REDCLIFFE WA 6104 T: (08) 9475 1600
www.mcintoshandson.com.au    perth@mcson.com.au



Quote No.:RG0745

Revision No.: 01

Quote date: 30th September 2024

Quote expiration date: 30th November 2024

Prepared by

Richard Gainsford
 Mob: 0438 383 517
 Email: R.Gainsford@mcson.com.au

Equipment	Quantity	Quoted Price (exc. GST)
Case 865B Series 2 Motor Grader	1	\$424,000.00

Specifications

Please see attached brochure for detailed specifications

Machine Features

- 220hp FPT Tier 3 diesel engine – no AdBlue
- Bi-directional hydraulic reversable cooling fan
- Cyclone pre-cleaner
- 44km/h travel speed
- 6F/3R speed auto shifting Powershift transmission electronically controlled
- 4 Wheel drive
- 17,180 kg operating weight
- 14FT multi-radius moldboard with blade float
- External circle teeth with forward drive gear – no need for slip clutches or shear pins
- Wet type inboard, adjustment free brakes
- Ground access service points
- Hydraulic diff lock
- 17.5Rx25 tires on 3-piece 10x24” rims
- Electronic lift engine hood for full engine access
- Remote diagnostics with Case Sitewatch Advanced with 3-year subscription

Blade

- External circle teeth with forward drive gear – no need for slip clutches or shear pins
- 14ft blade width
- 671mm blade height
- 22.2mm blade thickness
- End bits overlay
- Multi radius blade design
- Hydraulic system designed for blade float
- Moldboard shock absorption accumulators
- Multi lever blade controls
- Slope Meter (In cab)
- Full blade positioning capabilities with 90deg bank cutting left & right side



McIntosh Holdings Pty Ltd ABN 28 008 675 876 T/AS McIntosh & Son
 547 Great Eastern Highway REDCLIFFE WA 6104 T: (08) 9475 1600
www.mcintoshandson.com.au perth@mcson.com.au



Quote No.:RG0745

Revision No.: 01

Attachments

Rear ripper/scarifier with 5 ripper shanks & 9 scarifier tines
Front and rear tow points (4T rated)
500kg Push block mounted to front of the machine

Operator Station

All necessary instrumentation/gauges including hazard warning system
Hand lever controls
Articulation and slope indicators
Enhanced sound suppression
Hour meter
Turbo timer
Reverse camera
Integrated HVAC air conditioning with pre cleaner
Darkest legal tinted windows
Rear window wiper washer
Rear window defroster
Sunshade
External mounted rearview mirrors
Fully adjustable air suspension seat
Canvas seat cover
Seat belt
Rubber floor mat
AM/FM stereo radio with Bluetooth connectivity
80 channel UHF radio
Personal storage compartment

Electrical

2x LED Beacons on roof
High & low headlights
Lights: Front – 2 x Headlight, 2 x Cab, 2 x Blade
Rear – 2x Work lights
Lockable Battery Isolator
2x In Cab 12V Power Source
External jump start points
2x E-stops

General details

9kg fire extinguisher
Front light guarding
Transmission guard
Battery isolator
Two (2) sets of keys
Operator Manual
Fuel tank capacity 341L
12V Air compressor for tire filling
Sign writing "Shire of Quairading" in prominent position each side of machine.



McIntosh Holdings Pty Ltd ABN 28 008 675 876 T/AS McIntosh & Son
547 Great Eastern Highway REDCLIFFE WA 6104 T: (08) 9475 1600
www.mcintoshandson.com.au    perth@mcson.com.au



Quote No.:RG0745

Revision No.: 01

Registration & Delivery

Registered on the Shire of Quairading Bulk license
 Delivery to Shire of Quairading depot

Warranty

3 years / 5000 hrs

Pricing

Case 865B Series 2 Motor Grader	Selling Price Excluding GST	\$424,000.00
	GST Component	\$42,400.00
Selling Price Including GST		\$466,400.00
Less trade in of 2014 CAT 12M Motor Grader	Inc GST	\$244,200.00
Total Change Over Price	Inc GST	\$222,200.00

Optional Extras pricing (ex GST)

- 2D Grade control system with automatics (same as non-GPS CAT grade system) \$32,150.00
- 3D grade control system with automatics (same as GPS CAT grade system) \$78,600.00
- Groeneveld Twin Pump Auto Greaser 8kg \$18,230.00

Payment Terms

Payment in 30 days from invoice

Quote Validity

Pricing is subject to change without notice. Please refer to the standard terms and conditions within.

Delivery

At time of tender a Case 865B grader is available at McIntosh & Son Perth. This can be made ready for delivery in 3-4 weeks from order.

Freight

Pricing include delivery and operator handover training to Shire of Quairading depot.



McIntosh Holdings Pty Ltd ABN 28 008 675 876 T/AS McIntosh & Son
 547 Great Eastern Highway REDCLIFFE WA 6104 T: (08) 9475 1600
www.mcintoshandson.com.au perth@mcson.com.au



Quote No.:RG0745

Revision No.: 01

Qualitative Criteria

Parts

Each McIntosh & Son parts department is staffed by skilled personnel with years of experience in Agricultural, Construction and Grounds Care equipment so you receive professional service and parts sourcing when a part is urgently required.

Our warehouses are stocked with genuine parts and service consumables from our suppliers. We are also agents and stockists of other quality parts suppliers. All our branches are computer linked to major suppliers to provide efficient turn arounds in the event of a breakdown.

Our parts departments offer after hours capabilities for parts ordering and dispatch.

The Shire of Murray are welcome to visit our Perth warehouse upon request

Service

Servicing will be carried out as per the manufacturer specifications. Please refer to the attached maintenance chart for servicing intervals and inclusions/exclusion.

Servicing and repairs work can be booked by contacting our branch.

Our service teams are trained to use the latest manufacturer electronic service tools, ensuring you get up and running as quickly as possible.

The McIntosh & Son service team has over 100 professionals across the state, including technicians, auto electricians, fabricators and apprentices who aim to deliver the best service to everyone and keep your farm, agricultural and construction machinery or equipment in optimal condition. Services we offer include:

- First Service
- Service and Repairs
- Air-conditioning
- Pre-season Service
- Machine inspection
- Breakdowns
- Electrical and hydraulic repairs
- Other maintenance



McIntosh Holdings Pty Ltd ABN 28 008 675 876 T/AS McIntosh & Son
547 Great Eastern Highway REDCLIFFE WA 6104 T: (08) 9475 1600
www.mcintoshandson.com.au    perth@mcson.com.au



Quote No.:RG0745

Revision No.: 01

Workshop Service

We have 12 workshops strategically located across Western Australia and Queensland to ensure your machines are always running in optimum condition. These are located in:

Western Australia (WA): Albany, Cunderdin, Esperance, Geraldton, Katanning, Kulin, Merredin, Moora, Narrogin, Perth, Wongan Hills and Queensland (QLD): Dalby.

Field Service

In addition, McIntosh & Son has a fleet of field service vehicles ready to respond quickly to assist you at your own location. The field service vehicles are well equipped to ensure your farm, agricultural and construction machinery and equipment are kept in optimal condition. Our field service capabilities are also available outside of business hours for any breakdown or urgent repair situations

Our Team

With a widespread range of knowledge, our team is here to support from sales right through to after product care. Meet some of key member of the team below:



MIKE FOSKETT

General Manager

Mike previously led the Perth team for 7 years until 2010. He returned to the dealership in the lead role after a number of years with a manufacturer.

In his role, Mike oversees all parts of the business including Sales, Service & Parts. Mike strives to deliver a customer-centric approach while supporting staff to ensure they can focus on providing excellent customer service.



McIntosh Holdings Pty Ltd ABN 28 008 675 876 T/AS McIntosh & Son
 547 Great Eastern Highway REDCLIFFE WA 6104 T: (08) 9475 1600
www.mcintoshandson.com.au perth@mcson.com.au



Quote No.:RG0745

Revision No.: 01



ANDREW CALVERT

Service Manager

Andrew brings with him a wealth of knowledge from the service and mining industries, with roles such as mine fire & rescue, industrial paramedic, mine site medic and most recently, service and workshop manager looking after Case Construction machinery.

Andrew is the first point of contact for any service and maintenance queries.



NICK JOSE

Parts Manager

Nick came onboard to strengthen and grow our parts capabilities, to great success.

Nick has over 10 years leadership experience with WA leading construction supplier WesTrac.

The branch prioritises stocking a large number of parts locally in Perth, with direct access to 12 other WA dealership locations to assist with demand as needed.



RICHARD GAINSFORD

Sales - Construction

Richard has over 8-years of sales and service experience within the Local Government sector in WA through construction and turf equipment. A strong understanding of operational needs, and problem solving is what helps Richards' customers get the best needs for their fleet.

Richard is always willing to carry out any operator training and support onsite.



McIntosh Holdings Pty Ltd ABN 28 008 675 876 T/AS McIntosh & Son
 547 Great Eastern Highway REDCLIFFE WA 6104 T: (08) 9475 1600
www.mcintoshandson.com.au perth@mcson.com.au



Quote No.:RG0745

Revision No.: 01

Offer and Acceptance

If you wish to accept the quotation presented here, please sign below. Your signature constitutes an offer by you to purchase the goods on the terms and conditions set out in this document.

McIntosh and Son’s terms and conditions of sale are included herein.

Contract and Acknowledgements

SIGNING SECTION

By signing this document the Purchaser hereby confirms the accuracy of the information provided herein and agrees to the Dealer’s Terms and Conditions of Sale a copy of which is available upon request.

Executed as a deed

Signed by the Applicant

Signed by the Dealer

Signed for and on behalf of the Applicant

Signed for and on behalf of the Dealer

Name of signatory

Name of signatory

Capacity of signatory e.g. director / partner

Capacity of signatory e.g. branch manager

Date

Date



McIntosh Holdings Pty Ltd ABN 28 008 675 876 T/AS McIntosh & Son
547 Great Eastern Highway REDCLIFFE WA 6104 T: (08) 9475 1600

www.mcintoshandson.com.au perth@mcson.com.au

TERMS AND CONDITIONS OF SALE

NOTE: The Australian Consumer Law and other legislation have provisions that may not be contracted out of. Accordingly where those mandatory provisions apply, they override provisions to the contrary in these Terms and Conditions.

1. INTERPRETATION

In these Terms and Conditions unless the context otherwise requires:

- (a) a reference to a party includes a reference to the party's successors and permitted assigns and any person claiming under or through the party;
- (b) every agreement or obligation expressed or implied in this Deed by which two or more persons agree or are bound shall bind such persons jointly and each of them severally;
- (c) a reference to a group of persons includes a reference to all of them collectively, any two or more collectively and each of them individually;
- (d) a reference to the Agreement includes these Terms and Conditions of Sale;
- (e) "ACL" means the Australian Consumer Law Schedule of the Competition and Consumer Act 2010 (Cth) as amended.
- (f) "Purchaser" means the party or parties defined as the Purchaser in the Agreement.;
- (g) "Authorised Representative" means the Dealer's Branch Manager or such person as may be authorised by the Dealer from time to time;
- (h) "the Dealer" means McIntosh Holdings Pty Ltd (ABN 28 008 675 876) (ACN 008 675 876) trading as McIntosh and Son WA;
- (i) "Conditions"/"Terms"/"Terms and Conditions" or similar expressions means these Terms and Conditions of Sale forming part of the Agreement;
- (j) "consumer" is as defined in the ACL and in determining if the Purchaser is a consumer, the determination is made if the Purchaser is a consumer under the Agreement.
- (k) "goods" means goods supplied or ordered under this Agreement
- (l) "GST" means the goods and services tax as imposed by the GST Law together with any related interest, penalties, fines or other charge.
- (m) "GST Law" has the meaning given to that term in A New Tax System (Goods and Services) Act 1999 (Cth) as amended.
- (n) "including" and similar expressions means "including, but not limited to";
- (o) "Person" includes an individual, the estate of an individual, a body politic, a corporation, an association (incorporated or unincorporated) and a statutory or other authority.
- (p) "PPSA" means the Personal Property Securities Act 2009 (Cth) as amended.
- (q) "Purchase Price" means the price for the goods or services set out in the Agreement, Quotation or Dealer's invoice.
- (r) "Quotation" means the form of quotation submitted by the Dealer to the Purchaser in which these Terms are deemed to be incorporated.
- (s) "services" means services supplied by the Dealer to the Purchaser.
- (t) "Special Goods" means any goods which are, at the Purchaser's request, embellished, machined, cut-to-size or specifically modified for the Purchaser.

2. STATEMENTS

- 2.1 A document signed by the Authorised Representative indicating the amount owing by the Purchaser is prima facie evidence of that amount owing, except in the case of manifest error.
- 2.2 Payment for Goods and/or Services is due in accordance with these Terms and Conditions of Sale.

3. REPRESENTATIONS

The Purchaser (and the Directors and Partners of the Purchaser, if applicable) warrants as to the correctness of the information which it has furnished to the Dealer in this Agreement, and acknowledges that the Dealer has relied upon this information in determining whether or not to enter into this Agreement.

4. CHARGE

- 4.1 The Purchaser charges all its right, title and interest in any land that it owns currently or may acquire in the future solely or jointly or have or become to have a beneficial interest in, in favour of the Dealer, with due and punctual observance of all of the obligations of the Purchaser under the Agreement.
- 4.2 The Purchaser indemnifies the Dealer against all expenses and legal costs (on an indemnity basis) for preparing, lodging and removing any caveat.
- 4.3 The Purchaser hereby acknowledges that the Dealer may at its discretion register and lodge an absolute caveat(s) on such property or properties in respect of the interest conferred on it under this clause 6. Such registration of a caveat by the Dealer over the Purchaser's property or properties must not be challenged by the Purchaser in any way whatsoever, and the Purchaser agrees not to take any steps in filing a "lapsing notice" via the Land Titles Office to have the caveat removed, until such time that the Purchaser has paid all monies owing by it to the Dealer as claimed from time to time.

5. ASSIGNMENT

The Purchaser must not assign or transfer any of its rights or obligations in connection herewith to any other person whatsoever.

6. CHANGE IN CONTROL

- 6.1 The Purchaser must advise the Authorised Representative in writing no later than fourteen (14) days before a charge in effective control of the Purchaser or of any change or alteration of any particulars contained in this Agreement (if applicable).
- 6.2 The Dealer (upon receipt of such advice) is entitled to review the Agreement and in its sole discretion, to terminate the Agreement upon seven (7) days written notice (the "Notice Period") to the Purchaser.
- 6.3 In such circumstances, the Dealer is entitled to payment by the Purchaser of a sum equal to the cost of Goods and/or Services then unpaid by the Purchaser upon expiry of the Notice Period. The Purchaser shall indemnify the Dealer in respect of any loss arising from the Purchaser's failure to so notify.
- 6.4 If the Purchaser signs the Agreement as the trustee of any trust (the "Trust"), the Purchaser is personally liable for the performance of all covenants contained in the Agreement and agrees that the Dealer's right of recourse pursuant to this Agreement shall not be limited to the Purchaser's assets but shall extend the assets of the Trust.

7. GOVERNING TERMS AND CONDITIONS

These are the only Terms which are binding upon the Dealer with the exception of those otherwise agreed in writing by the Dealer or which are imposed by a statute and which cannot be excluded. Any direction by the Purchaser either verbal or written to procure goods or services from the Dealer will be deemed as acceptance by the Purchaser of these Terms, despite any provisions to the contrary in the direction or any purchase order issued by the Purchaser.

8. TERMS OF PAYMENT

- (a) The Purchaser must pay the Purchase Price in full prior to delivery of the goods and/or services.
 - (b) The Purchaser is not entitled to make any deduction from amounts owing to the Dealer in respect of any set off or counterclaim to be held back for retention.
- 9. PAYMENT DEFAULT**
- (a) If the Purchaser defaults in payment by the due date of any amount payable to the Dealer then all money which would become payable by the Purchaser to the Dealer at a later date on any account, becomes immediately due and payable without the requirement of any notice to the Purchaser, and the Dealer may, without prejudice to any of its other accrued or contingent rights:
 - (i) charge the Purchaser interest on any sum due at the prevailing rate of 15% per annum for the period from the due date until the date of payment in full;
 - (ii) charge the Purchaser for, and the Purchaser must indemnify the Dealer from, all costs and expenses (including without limitation indemnity legal costs) incurred by it resulting from the default or in taking action to enforce compliance with the Agreement or to recover any goods;
 - (iii) cease or suspend supply of any further goods or services to the Purchaser;
 - (iv) by written notice to the Purchaser, terminate any uncompleted contract with the Purchaser.
 - (b) Clause 9(a) may also be relied upon, at the Dealer option:
 - (i) where the Purchaser is a natural person and becomes bankrupt or enters into any scheme of arrangement or any assignment or composition with or for the benefit of his or her creditors or any class of his or her creditors generally; or
 - (ii) where the Purchaser is a corporation and it enters into any scheme of arrangement or any assignment or composition with or for the benefit of its creditors or any class of its creditors generally, or has a liquidator, administrator, receiver, manager or similar functionary appointed in respect of its assets, or any action is taken for, or with the view to, the liquidation (including provisional liquidation), winding up or dissolution without winding up of the Purchaser.
- 10. INSPECTION AND ACCEPTANCE**
- (a) If the Purchaser is a consumer, nothing in these Terms and Conditions limits any remedy available pursuant to the ACL save as permitted under the ACL.
 - (b) The Purchaser must inspect all goods upon delivery and within 48 hours of delivery give written notice with full details and description to the Dealer named in the relevant Sales Invoice if the Purchaser alleges that the goods are not in accordance with the Purchaser's order. Failing such notice, the goods shall be deemed to have been delivered to and accepted by the Purchaser.
 - (c) When any non-compliance with the Purchaser's order is accepted by the Dealer, the Dealer may, at its option, replace the goods, or refund the price of the goods.
- 11. RETURNS**
- Unless otherwise agreed, returns other than required pursuant to the ACL must be approved by the Dealer named in the relevant Sales Invoice. These authorised returns must be freight prepaid and will only be accepted if they are in a saleable condition. The Dealer reserves the right to charge a handling fee [equal to 10% of the price of the goods] for goods returned under this provision. Unless required by the ACL, Special Goods are not returnable.
- 12. QUOTATIONS**
- (a) Unless previously withdrawn, a Quotation is valid for 30 days or such other period as stated in it whichever period is the lesser. A Quotation is not to be construed as an obligation to sell or provide services but merely an invitation to treat and no contractual relationship shall arise from it until the Purchaser's order has been accepted in writing by the Dealer.
 - (b) The Dealer is not bound by any conditions attaching to the Purchaser's order or acceptance of a Quotation and, unless such conditions are expressly accepted by the Dealer in writing, the Purchaser acknowledges that the Purchaser's conditions are expressly negated.
 - (c) Every Quotation is subject to and conditional upon obtaining any necessary import, export or other licence.
- 13. PRICING**
- The parties agree that the Purchase Price does not include GST unless otherwise stated.
- 14. PASSING OF PROPERTY AND RISK**
- (a) Goods supplied by the Dealer to the Purchaser shall be at the Purchaser's risk immediately upon delivery to the Purchaser, into the Purchaser's custody or at the Purchaser's direction (whichever happens first). The Purchaser shall insure the goods from the time of that delivery at its cost against such risks as it thinks appropriate, shall note the interest of the Dealer on the insurance policy and shall produce a certificate to this effect to that Seller upon request.
 - (b) Property in the goods supplied by the Dealer to the Purchaser under these Terms shall not pass to the Purchaser until those goods and other goods have been paid for in full.
 - (c) Until the Dealer receives full payment in cleared funds for all goods and services supplied by it to the Purchaser, as well as all other amounts owing to the Dealer by the Purchaser:
 - (i) the Purchaser shall store the goods in a manner which shows clearly that they are the property of the Dealer; and
 - (ii) the Purchaser may sell the goods in the course of its business and shall account to the Dealer for the proceeds of sale (including any proceeds from insurance claims). These proceeds must be kept in a separate bank account with a bank to whom the Purchaser has not given security however failure to do so will not affect the Purchaser's obligations as trustee.
 - (d) In addition to the Dealer's rights under the PPSA, the Purchaser irrevocably authorises the Dealer at any time to enter onto any premises upon which:
 - (i) the Dealer's goods are stored to enable the Dealer to inspect the goods and/or if the Purchaser has breached these Terms, reclaim the goods;
 - (ii) the Purchaser's records pertaining to the goods are held to inspect and copy such records.
 - (e) The Purchaser and the Dealer agree that the provisions of this clause apply notwithstanding any arrangement under which the Dealer grants credit to the Purchaser.
- 15. PERSONAL PROPERTY SECURITIES ACT**
- (a) Notwithstanding anything to the contrary contained in these Terms, the PPSA applies to these Terms.
 - (b) For the purposes of the PPSA:
 - (i) terms used in this clause 15 that are defined in the PPSA have the same meaning as in the PPSA;
 - (ii) these Terms are a security agreement and the Dealer has a Purchase Money Security Interest in all present and future goods supplied by the Dealer to the Purchaser and the proceeds of the goods;
 - (iii) the security interest is a continuing interest irrespective of whether there are monies or obligations owing by the Purchaser at any particular time; and

- (iv) the Purchaser must do whatever is necessary in order to give a valid security interest over the goods and their proceeds which is able to be registered by the Dealer on the Personal Property Securities Register.
- (c) The security interest arising under this clause 15 attaches to the goods when the goods are collected or dispatched from the Dealer's premises and not at any later time.
- (d) Where permitted by the PPSA, the Purchaser waives any rights to receive the notifications, verifications, disclosures or other documentation specified under sections 95, 118, 121(4), 130, 132(3)(d), 132(4), 135 and 157 of the PPSA.
- (e) The Dealer and the Purchaser agree to contract out of and nothing in the provisions of sections 96, 125, 129, 142 and 143 of the PPSA will apply to these Terms.
- (f) To the extent permitted by the PPSA, the Purchaser agrees that:
 - (i) the provisions of Chapter 4 of the PPSA which are for the benefit of the Purchaser or which place obligations on the Dealer will apply only to the extent that they are mandatory or the Dealer agrees to their Agreement in writing; and
 - (ii) where the Dealer has rights in addition to those in Chapter 4 of the PPSA, those rights will continue to apply.
- (g) The Purchaser must immediately upon the Dealer 's request:
 - (i) do all things and execute all documents necessary to give effect to the security interest created under this Agreement; and
 - (ii) procure from any person considered by the Dealer to be relevant to its security position such agreements and waivers (including as equivalent to those above) as the Dealer may at any time require.
- (h) The Dealer may allocate amounts received from the Purchaser in any manner the Dealer determines, including in any manner required to preserve any Purchase Money Security Interest it has in goods supplied by the Dealer.

16. SUPPLY

The Dealer reserves the right to suspend or discontinue the supply of goods to the Purchaser without being obliged to give any reason for its action.

17. PART DELIVERIES

The Dealer reserves the right to make part deliveries of any order, and each part delivery shall constitute a separate sale of goods upon these Terms. A part delivery of an order shall not invalidate the balance of an order.

18. DIMENSIONS, PERFORMANCE DATA AND OTHER DESCRIPTIVE DETAILS

If the Purchaser is a consumer, nothing in this clause limits any remedy available pursuant to the ACL save to the extent permitted. To the greatest extent permitted by law:

- (a) Photographs, drawings, illustrations, weights, dimensions and any other particulars accompanying, associated with or given in a Quotation, descriptive literature or a catalogue approximate the goods offered but may be subject to alteration without notice.
- (b) Any performance data provided by the Dealer or a manufacturer is an estimate only and should be construed accordingly.
- (c) Unless agreed to the contrary in writing, the Dealer reserves the right to supply an alternative brand or substitute product when necessary or appropriate.

19. SHIPMENT AND DELIVERY

(a) The means of delivery is at the Dealer's sole discretion.

(b) If the Dealer directs the Purchaser to collect the goods:

- (i) the Purchaser must collect the goods within 7 days of being advised they are ready;
- (ii) if the Purchaser does not collect the goods within this time, the Purchaser is deemed to have taken delivery of the goods and is liable for commercial storage charges payable to the Dealer monthly on demand.

(c) The Purchaser must pay to the Dealer on demand any delivery costs incurred by the Dealer if

- (i) the Purchaser requests another method of delivery from that outlined in (a) above; or
- (ii) the Purchaser elects to use an independent courier to deliver the goods and enters into a separate contract with that independent courier to deliver the goods.

20. MANUFACTURERS' CHANGES

To the greatest extent permissible under law where the Dealer is acting as agent for a manufacturer, the Dealer shall not be liable for any alteration or variation in the goods made by the manufacturer.

21. CURRENCY

Where goods are imported into Australia, any adverse variation in the price arising from fluctuation in exchange rates between the date of the Purchaser's order and the date of payment by the Dealer will be to the Purchaser's account.

22. CONTINGENCIES

Any charge, duty, impost, sales tax or other expenditure which is not applicable at the date of Quotation or invoice but which is subsequently levied upon the Dealer in relation to a Quotation or Sales Invoice as a result of the introduction of any legislation, regulation or governmental policy, shall be to the Purchaser's account.

23. CHARGES BEYOND POINT OF DELIVERY QUOTED

Unless otherwise agreed in writing, if the Dealer prepays freight, insurance, custom and import duties (if any), landing and delivery charges and all other charges in connection with shipment and delivery of the goods, then any such charges shall be to the Purchaser's account.

24. FORCE MAJEURE

If the Dealer's performance or observance of any obligations is prevented, restricted or affected by reason of a force majeure event including strike, lock out, industrial dispute, raw material shortage, breakdown of plant, transport or equipment or any other cause beyond the Dealer's reasonable control, the Dealer may, in its absolute discretion give prompt notice of that cause to the Purchaser. On delivery of that notice the Dealer is excused from such performance or observance to the extent of the relevant prevention, restriction or effect.

25. DEALER'S CANCELLATION

(a) If the Dealer is unable to deliver the goods, then it may cancel the Purchaser's order (even if it has been accepted) by written notice to the Purchaser and limits its liability to the Purchaser in that regard to the greatest extent permitted under law.

(b) If the Purchaser commits a breach of its obligations under the Agreement, then the Dealer may, without prejudice to any other rights or remedies terminate the Agreement and seek damages for any loss suffered.

26. PURCHASER'S CANCELLATION

(a) To the greatest extent permitted under law, the Purchaser shall have no right to terminate the Agreement or cancel an order which has been accepted by the Dealer unless otherwise agreed in writing. If a right of cancellation is granted to the Purchaser, such right of cancellation must be exercised in accordance with the relevant terms of cancellation and by notice in

writing from the Purchaser to the Dealer with which the order has been placed not later than 7 days prior to the estimated date of shipment by the manufacturer or that Seller as the case may be.

(b) Unless otherwise agreed between the Purchaser and Seller, upon cancellation prior to shipment any deposit paid by the Purchaser shall be forfeited to the manufacturer or Seller (as the case may be).

(c) Despite the cancellation of any order for any reason, the Purchaser must still purchase from the Dealer any goods ordered by the Purchaser which constitute Special Goods (whether in store, in transit or being manufactured) which were procured or ordered by the Dealer before such cancellation, unless otherwise agreed in writing by the Dealer.

27. WARRANTY AND LIABILITY OF SELLER

(a) The Dealer makes no express warranties under these Terms.

(b) Except as the Terms specifically state, or as contained in any express warranty provided in relation to the goods or services, the Agreement does not include by implication any other term, condition or warranty in respect of the quality, merchantability, acceptability, fitness for purpose, condition, description, assembly, manufacture, design or performance of the goods or services or any contractual remedy for their failure.

(c) If the Purchaser is a consumer nothing in these Terms restricts, limits or modifies the Purchaser's rights or remedies against the Dealer for failure of a statutory guarantee under the ACL save as permitted under the ACL.

(d) If the Purchaser on-supplies the goods to a person who is a consumer, or uses up or transforms the goods in the course of trade then:

(i) if the goods or services are not of a kind ordinarily acquired for personal, domestic or household use or consumption, then the amount specified in section 276A(1) of the ACL is the absolute limit of the Dealer's liability to the Purchaser;

(ii) otherwise, payment of any amount required under section 274 of the ACL is the absolute limit of the Dealer's liability to the Purchaser;

howsoever arising under or in connection with the sale, installation, use of, storage or any other dealings with the goods or services by the Purchaser or any third party.

(e) If sub clauses 27(b) and 27(c) of these Terms and Conditions do not apply, then other than as stated in the Terms and Conditions or any written warranty statement then, to the greatest extent permitted under law, the Dealer is not liable to the Purchaser in any way under or in connection with the sale, installation, use of, storage or any other dealing with the goods or services by the Purchaser or any third party.

(f) To the greatest extent permitted under law the Dealer is not liable for any indirect or consequential losses or expenses suffered by the Purchaser or any third party, howsoever caused, including but not limited to loss of turnover, profits, business or goodwill or any liability to any other party.

(g) The Purchaser expressly acknowledges and agrees that:

(i) it has not relied upon, any service involving skill and judgement, or on any advice, recommendation, information or assistance given by the Dealer, its agents or employees in relation to the goods or services or their use or purpose.

(ii) it has not made known, wither expressly or by implication, to the Dealer any purpose for which it requires the goods or services and it has the sole responsibility of satisfying itself that the goods or services as suitable for the use of the Purchaser.

28. ALTERATION TO CONDITIONS

The Dealer may, at any time and from time to time, alter these Terms and Conditions by providing notice to the Purchaser.

29. GOVERNING LAW

These Terms and Conditions shall be governed by the laws of Western Australia. The parties agree to submit to the exclusive jurisdiction of the Courts in Perth, Western Australia.

30. WAIVER

The Dealer's failure to enforce any of these Terms and Conditions shall not be construed as a waiver of any of the Dealer's rights.

31. WRITTEN NOTICE

A notice must be in writing and handed personally or sent by email, facsimile or prepaid mail to the last known address of the addressee. Notices sent by pre-paid post are deemed to be received upon posting. Notices sent by facsimile or email are deemed received on confirmation of successful transmission.

32. NO ADVERSE CONSTRUCTION

These Terms and Conditions are not to be constructed to the disadvantage of the Dealer because the Dealer was responsible for their preparation.

33. SEVERANCE

33.1 If any provision of these Terms and Conditions

- (a) is or becomes void, voidable, illegal or unenforceable in its terms;
- (b) would not be void, voidable, illegal or unenforceable if it were read down; and
- (c) is capable of being read down,

then that provision will be read down accordingly.

33.2 If, notwithstanding clause 33.1, a provision of these Terms and Conditions is still void, voidable, illegal or unenforceable, then:

- (a) if the provision would not be void, voidable, illegal or unenforceable if some words were omitted, those words are severed; and
- (b) otherwise, the whole provision is severed,
- (c) and the rest of these Terms and Conditions will be of full force and effect.

34. ENQUIRIES & PRIVACY

(a) The Purchaser irrevocably authorizes the Dealer, its employees and agents to make such enquiries as it deems necessary to investigate and consider entering into and maintaining an agreement with the Purchaser from time to time including (but without limiting the generality of the foregoing) the making of enquiries of persons nominated as trade referees, the bankers of the Purchaser's any other credit providers (the information sources) and the Purchaser hereby authorizes the information sources to disclose to the Dealer such information concerning the Purchaser which is within their possession and which is requested by the Dealer.

(b) The Purchaser agrees to the Dealer's Privacy Policy, a copy of which is available from the Dealer upon request.

(c) The Dealer recognises the importance of protecting the privacy of the Purchaser. The Dealer is bound by the Privacy Act and the principles thereunder when handling personal information. Further details concerning privacy rights can be found at "The Office of the Australian Information Commissioner" website at <http://www.oaic.gov.au/>.



PERTH

Dealership Reputation

Please see below a list of references for previously supplied machines

Shire of Cocos Islands

The Shire purchase their Case 865B grader in 2016 through a tender process. They have been very happy with the performance and backup we have been able to provide on the machine from Perth.

Contact: Martin Faulkner martin.faulkner@cocos.wa.gov.au

SCA Earthmoving

In 2022 SCA Earthmoving purchase a Case 836C grader with rear ripper option as an upgrade to their old grader. The machine was demonstrated on site for Charlie and his team and was delivered in 3-4 weeks from order.

Contact: Charlie Guilotto - 0418 953 660

Karoonda Council

Purchased a Case 865B grader for road construction works from our dealer SA Tractors.

Contact: Martin Borgas (CEO) 0468 348 777

Elliston Council

Purchased a Case 865B grader for road construction works from our dealer SA Tractors.

Contact – Tim Mills 08 8687 9177

Mt Remarkable Council

Purchased a Case 865B grader for road construction works from our dealer SA Tractors.

Contact: Michael McCabe – 08 8666 2014

RAM Equipment

RAM equipment recently purchased 2 x Case 865B graders from our dealer SA Tractors. for their equipment hire fleet in South Australia. Operating multiple Case machines in their fleet gave them confidence in the brand to put 2 graders in amongst their John Deere grader fleet.

Contact: Daniel 0417 026 439

Shire of Perenjori

A new Case 695Sv Backhoe has been recently delivered to the Shire in August 2023. This was spec'd with front and rear quick hitches, 4in1 bucket, forks, and rake grab bucket, and full Shire additions as needed.

Contact: Ken Markham (Works Manager) 0427 731 002

Department of Parks & Wildlife WA

Late in 2022 and 2023 we have delivered 2x Case 590SV backhoes to the Department for works in Busselton and Walpole. Replacing JCB back hoes, the Case was chosen for its stability, operator comfort/visibility, and customer support previously experienced with other product from McIntosh & Son

Contact: Stephen Hebert 0400 910 578

Shire of Manjimup

Early in 2023 a Case 695sv backhoe was purchased to replace a Cat machine for Shire the operations depot in Pemberton. With front and rear quick hitches, equal size tires, and 4-wheel steering, and Shire specifications met.

Contact: Andrew Johns (Works Manager) 0427 472 935

Shire of Esperance

The Shire of Esperance currently operates 3x Case 695 model backhoes across their works department. These were delivered in 2021.

Contact: Paul Farmilio (Fleet Manager) 0437 999 014

McINTOSH HOLDINGS PTY LTD (ABN 28 008 675 876 ACN 008 675 876) T/AS McINTOSH & SON WA

Telephone: (08) 9475 1600 Email: perth@mcson.com.au
547 Great Eastern Highway, REDCLIFFE, Western Australia 6104
Fax: (08) 9479 1475 Visit www.mcintoshandson.com.au

Shire of Gnowangerup

The Shire of Gnowangerup currently operates multiple machines from McIntosh & Son. A Case 590ST backhoe, Case 721F wheel loader, and Case TR340 compact track loader.

Contact: Barry Gibbs – barry.gibbs@gnowangerup.wa.gov.au

City of Swan

In February 2023 we were successful in tendering 1x Case 921G Wheel loader & 2x Liugong 6524E Multi tire rollers to the City of Swan. These machines were successfully delivered on time and spec to the Shire early in 2023.

Contact: Sebastian Rosati – Sebastian.rosati@swan.wa.gov.au

Shire of Williams

CASE 721G Wheel loader delivered in 2020

The Shire of Williams tendered for a new wheel loader for roading and general council works. The machine was built with load scales, auto greasing, and a quick hitch, plus general safety additions such as fire extinguishers and beacons.

Contact: Tony Kett (Works Manager) 0419 941 829

Shire of Cranbrook

CASE 721G Wheel loader delivered in 2021

The Shire of Williams tendered for a new wheel loader for roading and general council works. The machine was built with load scales, auto greasing, and a quick hitch, plus general safety additions such as fire extinguishers and beacons.

Contact: Jeff Alderton (Works Manager) 0437 450 147

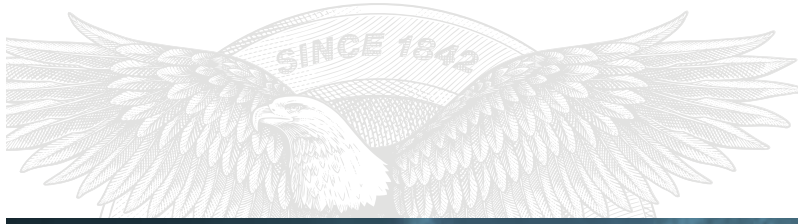

B-SERIES 2 MOTOR GRADERS

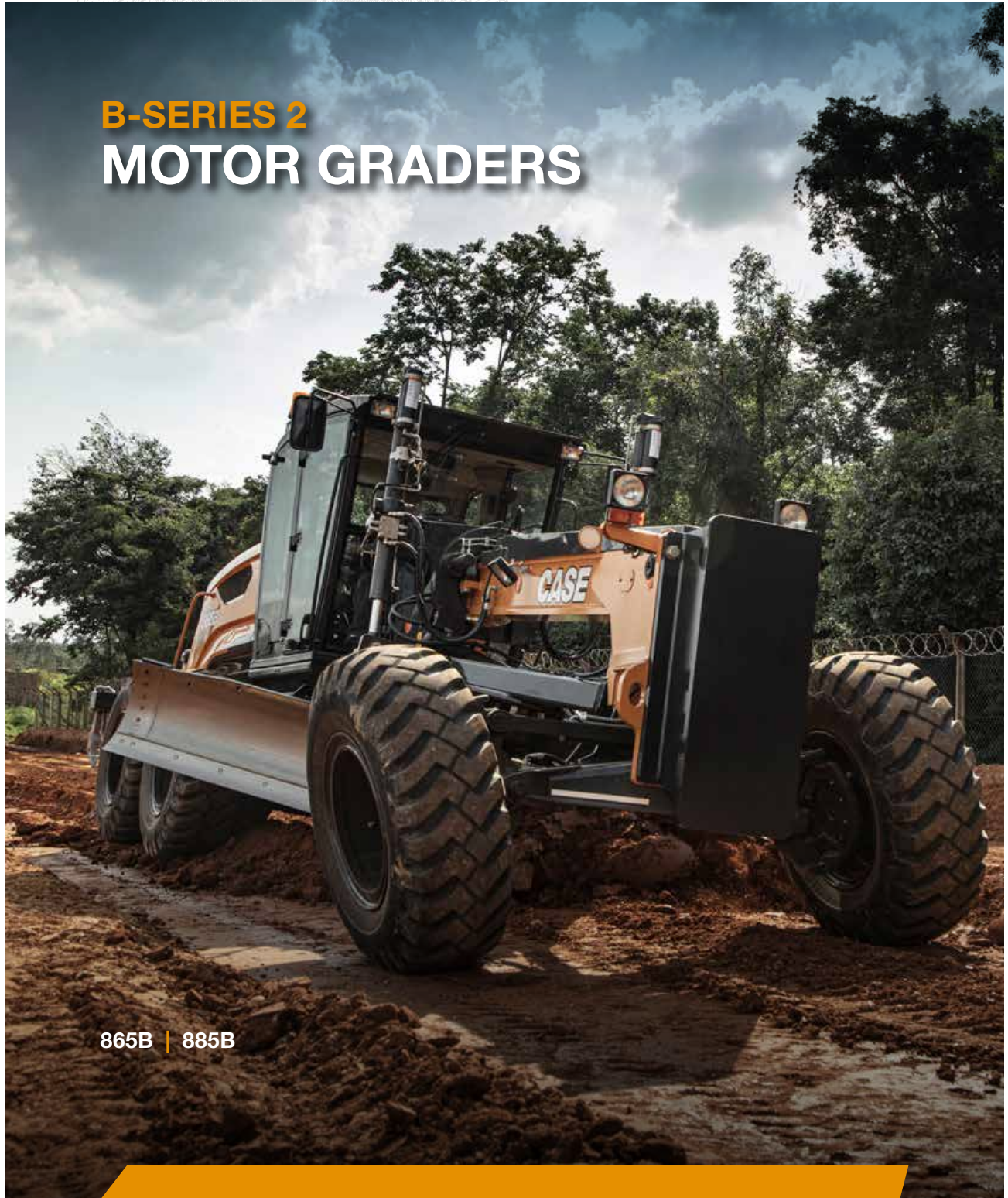

865B | 885B

B-SERIES 2 MOTOR GRADERS



- 1842** CASE is founded.
- 1869** The first CASE portable steam engine – road construction is born!
- 1957** The first factory-integrated loader/backhoe in the world: a CASE industry first.
- 1958** The first CASE 4-WD wheel loader, the W9, is introduced.
- 1967** CASE enters excavator market.
- 1998** Ride control on loader backhoes and skid steer loaders: another CASE first.

HERITAGE

A TRADITION OF INDUSTRY FIRSTS



- 2011** All around visibility cab introduction on 800 series and FPT TIER III Engine installation (“B series”)
- 2012** Torque converter introduction on flagship model 885B
- 2015** CASE graders enter the European market with the new T4 final /EU Stage IV models.
- 2022** Machine productivity and reliability improve with the introduction of the new CASE Graders B series 2
- 2022** C Series is launched with the T4 engine

MAIN REASONS TO CHOOSE THE B-SERIES 2

LOAD-SENSING HYDRAULIC SYSTEM

Balanced flow for all applications and for simultaneous moldboard movements.

TORQUE CONVERTER LOCK-UP

The CASE transmission combines the torque converter's typical smoothness, for fine grading, with the direct drive solution for full power transfer.

«A-SHAPE» FRAME

Optimised effort distribution in all conditions ensures a long operating life.

MULTI-RADIUS BLADE

Lower power absorption and optimised rolling effect.





REAR MOUNTED CAB

Best-in-class controllability and comfort: the operator is always in line with the working direction.

EASY ACCESS

The easy serviceability is in the CASE: all the main checks can be easily performed from ground level; all the service points are grouped and positioned to facilitate servicing.

VARIABLE POWER CURVE

The FPT Engine always delivers the power required for every task. On the 885B two power curves are available, while on the 865B three engine settings ensure even better performances.

EXTERNALLY DRIVEN CIRCLE TEETH

The external pinion is not subject to shocks while working in heavy grading, while the slewing ring's external teeth prevent the accumulation of residual material, extending the overall working life.

HIGH VERSATILITY

The wide variety of options enables every customer to tailor their grader to match the requirements of the most demanding applications.

B-SERIES 2 MOTOR GRADERS

TORQUE CONVERTER LOCK-UP

The machine drives faster with no extra torque

The lock-up system overrides the torque converter operation in machines featuring the B-Series' type of engine and transmission coupling. When it is activated, the lock turns the hydraulic coupling into a direct (rigid) coupling. The Lock-up system is automatically activated according to operating conditions, when the transmission electronics unit's torque and engine speed readings reach preset values. The Lock-up is usually activated in travel applications where no extra torque is required from the torque converter and the machine runs at a higher speed.

LOAD-SENSING HYDRAULIC SYSTEM

Highly responsive & precise control

The load-sensing hydraulic system helps maintain a balanced flow for all applications and for simultaneous moldboard movements. It ensures highly responsive and precise control, as well as easy and smooth operation. A directly activated axial piston pump only delivers the required amount of oil where it is needed, so that no power is wasted. The control valves ensure pressure compensation, enabling parallel lifting and lowering of the moldboard. A dedicated switch on the cab floor enables the operator to obtain maximum output from the hydraulic circuit independently from engine revolutions for faster reaction (Full Flow Mode).



MOLDBOARD PRECISION TECHNOLOGY

“A-SHAPE” FRAME

Longer working life

The durable front A-frame drawbar and high-strength circle provide outstanding stability. The A-frame drawbar features a heavy-duty boxed frame design that supports the circle with a wide stance, extending the life of the circle and drawbar components.



MULTI RADIUS BLADE

Productivity with less power

The CASE radius design of the reinforced involuted moldboard consists of three different radiuses. This enables a more efficient and continuous cutting mixing and rolling, and extends the life of the blade. The efficient mixing effect on the spread-out material improves the consistency and longevity of the road surface.



EXTERNALLY DRIVEN CIRCLE TEETH

Insensitive to shocks

CASE motor graders are designed with external circle teeth, which are easier to clean and provide a larger contact area. This prevents component wear and provides more leverage when turning the blade under load. As a result, there is no need for slip clutches or shear pins, which require repositioning or repairs.



B-SERIES 2 MOTOR GRADERS



ATTACHMENTS

THE ART OF VERSATILITY



FRONT COUNTERWEIGHT



FRONT PUSH PLATE



RIPPER



FRONT DOZER BLADE

HIGH VERSATILITY

CASE offers a variety of versatile grader attachments and accessories, including:

- Front counterweight
- Ripper
- Scarifier
- Front push plate - light 492kg
- heavy 800kg
- Front dozer blade
- Rear pull hook
- Additional lighting packages
- Lift cylinder accumulators
- Float control
- Moldboard extensions

B-SERIES 2 MOTOR GRADERS

VARIABLE POWER CURVE for excellent performance

From the unique moldboard design that rolls a superior mix and the fuel-efficient, turbocharged Tier 3 engine that delivers operating speeds of up to 38,8-44,1 km/h (depending on model), to the spacious rear-mounted cab that provides exceptional visibility on the machine's working components, the CASE B-Series 2 motor graders are designed for productivity. For an even greater performance, Dual Power maximises operation at higher speeds than the double (885B) or triple (865B) engine curve, which flattens from the 4th gear.

EASY ACCESS

Maintenance made easy

When you invest in CASE equipment, you look for duration. We make it simple. CASE B Series 2 motor graders are no exception. From the one-piece, flip-up hood and reversible fan option that blows debris out of the cooler, to ground-level site gauges and service points, the machine is designed for easy daily maintenance. It's done in just a matter of minutes, so you can obtain the effective performance and long life you want from your machine.



MAINTENANCE



- 1. Engine air filter
- 2. Fuel tank refill
- 3. External circle teeth
- 4. Hydraulic test ports
- 5. Tandem oscillation grease zerks
- 6. Dual batteries
- 7. Hydraulic oil level gauge
- 8. Electric flip-up hood
- 9. Oil drain hose



B-SERIES 2 MOTOR GRADERS

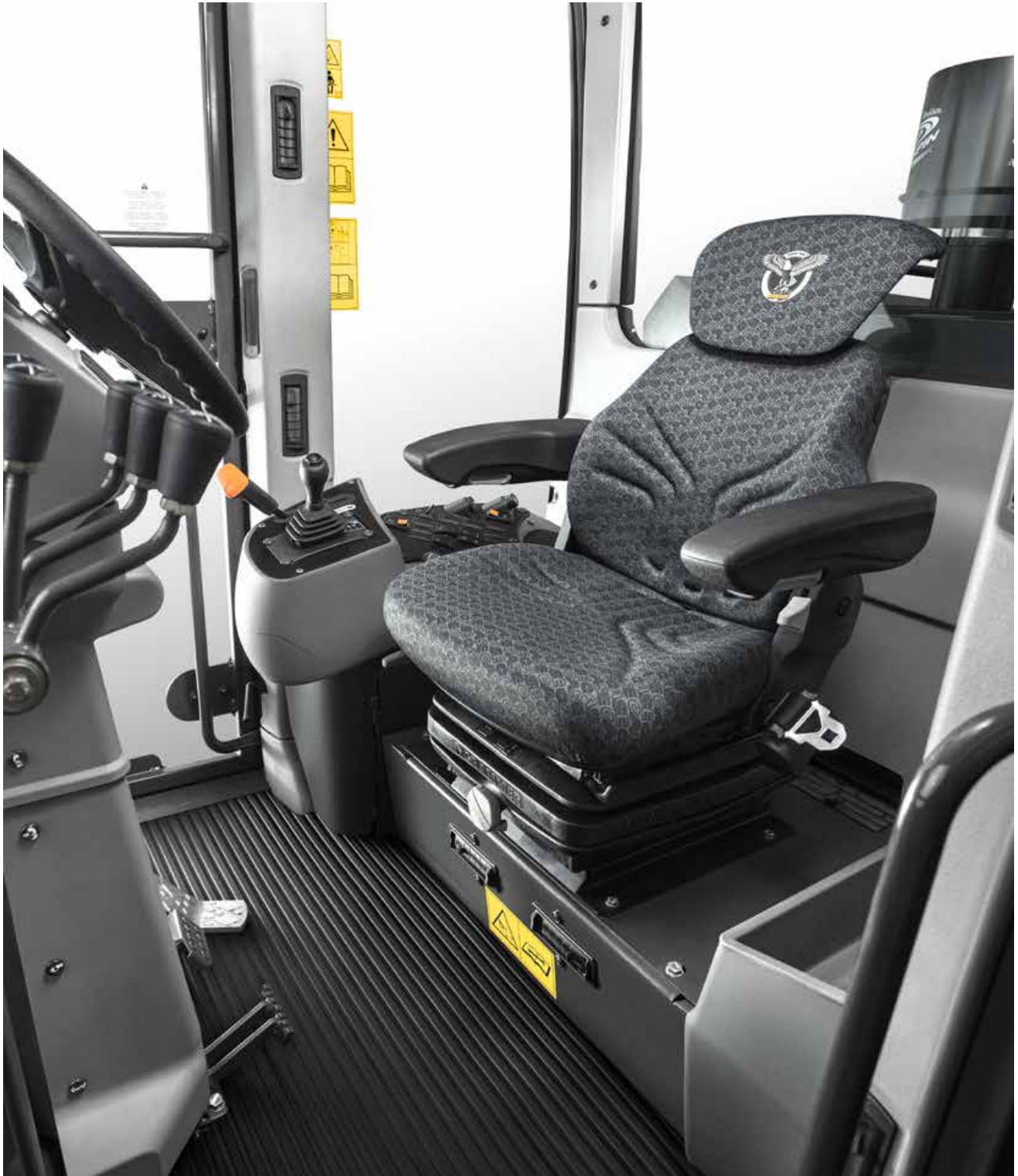

12

CAB COMFORT RULES

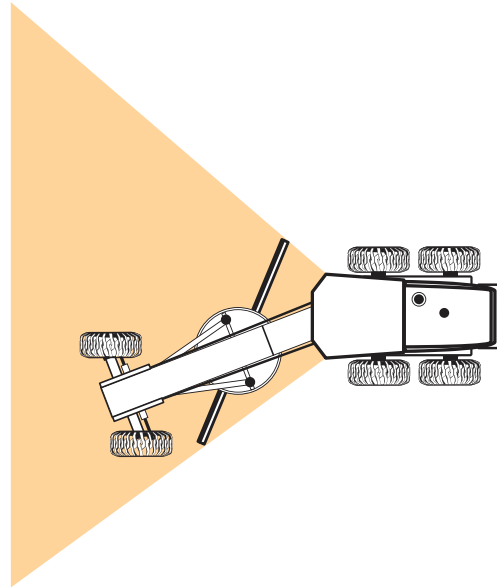

REAR MOUNTED CAB

Aligned with performance

The CASE front articulation design, unique in the industry, allows for the cab to be mounted further back on the machine. With this design, the operator remains in a centered position while the gooseneck is articulated, increasing visibility on the moldboard, circle, saddle and tires.

The front articulation enables the operator to see both the rear and front half of the machine without having to look to the side when the machine is articulated. In addition, it allows for a tight turning radius, ideal for working in cul-de-sacs and tight spaces.

MASSIVE CAB, MASSIVE COMFORT

Stress free operation

The Isomount cab reduces noise and vibration, and consequently operator fatigue. Couple that with a deluxe suspension seat with lumbar control and any operator will be not only comfortable, but more productive.

The sloping rear hood, breakaway heavy-duty side mirrors, and floor-to-ceiling glass with defrost rear window allow for outstanding visibility to the rear and to the front.

B-SERIES 2

MOTOR GRADERS

ENGINE		865B	885B
Brand		FPT F4HE9687C	FPT F4HE9687K
Type		Electronic common rail fuel system, water cooled, 4 cycle, direct injection, turbocharged and charge air cooled.	
Cylinders		6, in-line	
Bore/Stroke	mm	104 x 132	
Displacement	l (cm ³)	6.7 (6728)	
Horsepower @ 2200 rpm			
Gross (SAE J1995)			
Low Curve*	kW	144	164
Imperial	hp	193	220
Metric	hp	196	223
Medium Curve***	kW	153	-
Imperial	hp	205	-
Metric	hp	208	-
High Curve**	kW	164	175
Imperial	hp	220	234
Metric	hp	223	238
Net (SAE J1349)			
Low Curve*	kW	133	153
Imperial	hp	178	205
Metric	hp	181	208
Medium Curve***	kW	142	-
Imperial	hp	190	-
Metric	hp	193	-
High Curve**	kW	153	163
Imperial	hp	205	219
Metric	hp	208	222
Max Torque @1500/1600 rpm			
Gross (SAE J1995)			
Low Curve *	Nm	830	924
Medium Curve***	Nm	880	-
High Curve**	Nm	930	984
Net (SAE J1349)			
Low Curve	Nm	380	864
Medium Curve***	Nm	788	-
High Curve	Nm	930	924
POWERTRAIN			
Rear axle			
Vertical ground clearance	mm	380	359
Differential		Planetary with controlled differential hydraulic lock	Planetary with controlled differential hydraulic lock
Brakes		Disk, bathed in oil	
Number of disks per brake		5	6
Tandem			
Type	mm	Welded Plate (2204 x 631 x 200.5)	
Oscillation		20° in each direction	
Command chain pitch	mm	50.8	
Thickness of the internal and external side wall	mm	19	
HYDRAULIC SYSTEM			
Type		Closed center, load sensing	
Hydraulic pump		Piston pump, variable displacement pressure and flow compensated, load sensing	
Rated flow	l/min(gpm)	186 (49)@ 2200 rpm	
Pressure cut off	bar	193	
Control Valve		9 sections	

Notes: *Gears 1st, 2nd F e 1st, 2nd R
 ** Gears 3rd, 4th, 5th, 6th F e 3rd R
 *** Gears 3rd, 4th F e 3rd R

TRANSMISSION		865B	885B
Make/Model		ZF TC LOCK UP 6WG – 160	ZF TC LOCK UP 6WG – 210
Type		Full Powershift, torque converter	
Gears		6 forward / 3 reverse	
Self-diagnostic system		On board	
Speeds (Forward/Reverse)			
1st	km/h	5,2/5,5	4,5/4,8
2nd	km/h	8,1/13,1	6,9/11,7
3rd	km/h	12,4/30,3	11,1/27,4
4th	km/h	19,2/-	16,9/-
5th	km/h	28,7/-	25,9/-
6th	km/h	44,1/-	38,8/-
ELECTRICAL SYSTEM			
Power		24 V	
Alternator		90 A	
Batteries		2x100 Ah - low maintenance	
STEERING			
Type		Hydrostatic	
Steering wheel turns (lock to lock)		4.5/3.2	
Pump capacity @ 2200 rpm	l/min	41.8	
Pressure release valve	psi(bar)	2530 (175 integral with priority valve)	
Cylinders		2	
Supplemental steering	SAE 1011, ISO5012	Integral with steering system after Supplemental steering	
Steering angle		42°	
ARTICULATION			
Type		Hydraulically activated (with a lock valve)	
Angle		25° to the left/right	
Controls		Hydraulic	
CAPACITIES			
Engine	l	15	
Engine with filter	l	16	
Fuel	l	360	
Transmission	l	25	29
Transmission with filter	l	26	31
Engine water cooling system	l	32	
Hydraulic oil tank	l	90	
Total hydraulic system	l	148	
Circle turn housing	l	2.8	
Tandem case (each)	l	69	
SADDLE			
Locking system		Two cylinders	
Saddle positions		5	
FRAME			
Type - Front section		Box section	
Size	mm	254 x 298	
Type - Rear section		Beam (welded)	
Size	mm	220.5 x 327	220.5 X 327
DRAWBAR			
Type		"A" frame welded construction with center mounted circle turn motor	
Connection with the frame		Shim adjustable spherical joint	
CIRCLE			
Type		Welded construction	
Maximum outside diameter	mm	1752.6	
Rotation		360°	
Speed	rpm	1.2	
N° of supports in phenolic resin		4	

B-SERIES 2

MOTOR GRADERS

MOLDBOARD		865B	885B
Type		High-carbon steel	
Form		Involute curve	
Width	mm	3962	4267
Thickness	mm	22	
Cutting edge		2, interchangeable	
Blade pitch positions			
Normal pitch		47°	
Minimum pitch		42°	
Maximum pitch		87°	
Blade side shift			
Right	mm	686	
Left	mm	533	
Maximum bank-cutting angle (left and right)		90°	
Ground penetration (max.)	mm	711.2	
Lift above ground (max.)	mm	444.5	
Blade side shift and pitch		Hydraulic type	
FRONT SCARIFIER			
Cutting width	mm	1168	
Teeth		5 (opt, 11)	
Spacing between teeth	mm	229 (opt ,114.5)	
Lift above ground	mm	527	
Maximum penetration	mm	318	
Weight	kg	570	
REAR RIPPER			
Type		Parallelogram	
Cutting width	mm	2195	2340
Ripper teeth		3 (opt, 5)	3 (opt, 5)
Scrifier teeth		5 (opt, 9)	5 (opt, 9)
Lift above ground - Ripper teeth	mm	518	518
Maximum penetration - Ripper teeth	mm	437	437
Weight (3/5 teeth)	kg	795	850/890
DOZER BLADE			
Type		Front mounted	
Width	mm	2762	
Height	mm	953	
Lift above ground	mm	622	
Penetration	mm	165	
Weight	kg	1165	

OPERATING WEIGHT		865B	885B
Basic machine, cab with heater and A/C, ripper and front counterweight (torque converter transmission ZF, fully service, full fuel tank, lights, standard batteries and 80 kg operator)	kg	16864 (tires 14.00x24 Moldboard 13FT)	18120 (tires 17.5-25 12PR Moldboard 14FT)

GENERAL DIMENSIONS

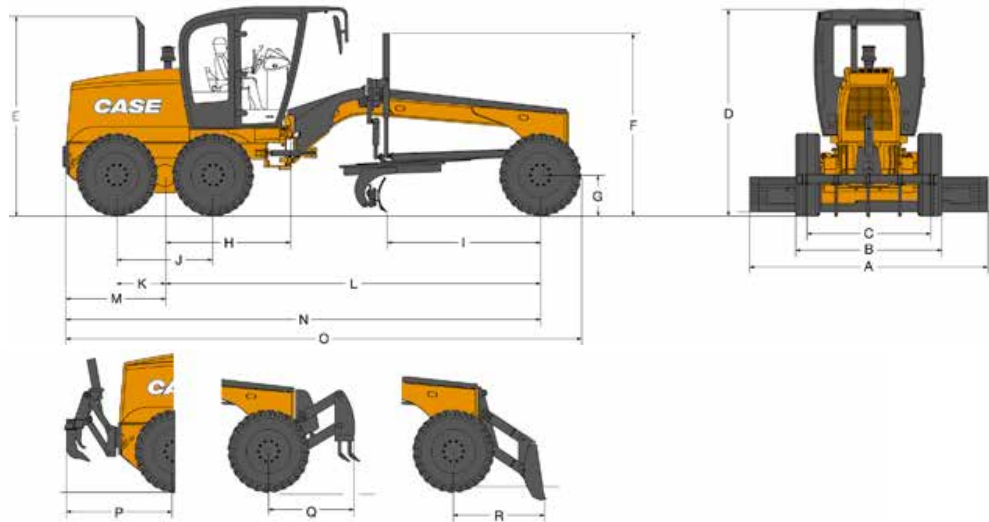

All units fitted with 14.0 x 24-12L tires, open ROPS/FOPS cab, standard battery, full fuel tank, operator weigh 80 kg, specifications in accordance with ISO 7134.

			865B	885B
A	Blade width	mm	3962	4267
B	Tread width	mm	2545	2583
C	Tread gauge	mm	2124	2162
D	Height on top of h.p. cab	mm	3400	3400
	Height on top of l.p. cab	mm	3200	3200
E	Height of top of exhaust	mm	3323	3323
F	Height to top of blade lift cylinder	mm	3047	3047
G	Tire static radius	mm	610	610
H	Distance between tandem center and the frame articulation pin	mm	1958	1958
I	Distance between the front axle and the blade	mm	2562	2562
J	Distance between the center of the rear tires	mm	1572	1624
K	Distance between tandem center and the wheel	mm	786	812
L	Wheelbase	mm	6219	6219
M	Distance between tandem center and the rear part of the equipment	mm	2064	2064
N	Distance between the front when axle and the rear part of the equipment	mm	8283	8283
O	Overall length	mm	8957	8957
P	Distance between the rear tires and the ripper	mm	2273	2247
Q	Distance between the front tires and the scarifier	mm	1520	1520
R	Distance between the front tires and the dozer blade	mm	1626	1626
	Outside tire turning radius	mm	7250	7250
	Ground clearance (rear axle)	mm	380	380
	Ground clearance (front axle)	mm	580	580



STANDARD AND OPTIONS

STANDARD EQUIPMENT

OPERATOR STATION

ROPS/FOPS open cab with:
Adjustable suspension vinyl seat, with a 50.8 mm (2") seatbelt
Adjustable operator console
Pedal accelerator
Manual accelerator
Front windshield wiper with washer
Safety glass
Ceiling light
Internal and external rear-view mirrors
12 V (*) power supply
Automatic master switch
Steps on the right and left sides
(* Only available in closed cabins)

ENGINE

865B FPT F4HE9687C
885B FPT F4HE9687K
Turbocharged, diesel
Dry air filter with primary and secondary safety elements
Air pre-filter with cyclonic dust ejector
80 A alternator
Swing-up hood, diesel

HYDRAULIC SYSTEM

Hydraulic system with load sensor, closed center
9-section control valve
Hydraulic control for all functions:
blade lifting (right and left side), circle turn, side shift of the circle, wheel lean, frame articulation, blade side shift and pitch, front and rear accessories
Diagnostics center with 8 quick couplers
Hydraulic axial piston pump

Hydraulic engine fan

BRAKES

Multidisk oil-bathed service brakes with nitrogen accumulator safety system
Disk parking brake integrated into the transmission with warning light

TIRES

14" 3-pieces rim / 17,25 x 25 - 12L - G2 tubeless

OTHERS

Standard tool kit
Drawbar / Standard circle

AXLES

Conventional differential with brakes on 4 wheels and differential locking with electrohydraulic mechanism (rear axle)

STEERING

Hydrostatic steering with integrated emergency system

INSTRUMENTS

Electronic Information Center
Indicators/gauges:
Tachometer
Direction selected F/N/R
Transmission modes - automatic/manual
Selected gear
Engine cooling temperature
Fuel level
Transmission oil temperature
Hydraulic oil temperature
Hourmeter
Fuel consumption
Engine diagnostics
Transmission diagnostics

INDICATOR LIGHTS:

Low fuel level
Floodlights
High beam
Brake pressure
Main alert

Parking brake

SOUND ALERTS:

Warning alert
Emergency alert
Reversing alert

ELECTRICAL SYSTEM

Lights
Front headlight with direction indicators (2)
Rear brake light and direction indicators (2)
Rear work light on top of the cabin (2)
Front work light on top of the cabin (2)
24 V system (Two 12 V batteries 12 V / 750 CCA)
Electronic system monitoring
Horn

Hourmeter
Reverse alarm

TRANSMISSION

ZF transmission of torque conversion type with lock up (also functions as Direct Drive), Powershift, 6 forward speeds and 3 reverse speeds, automatic gear shift, emergency electrical failure device (Limp-Home)

All ROPS/FOPS cabins are certified in accordance with the SAE J1040 (ROPS) and SAE J231 (FOPS) standards.

OPTIONS*

CAB

Closed high cab (fixed front window)
Closed high cab (front flip-down window)
Sunshade(front and rear)

OTHERS

Air conditioner for closed cab
Fire extinguisher
Windshield washer and lower windshield wipers
Rear windshield washer and wipers
Radio

Tandem lock device

Rear fogger

DRAWBAR

Drawbar / Heavy Duty circle

FRONT ATTACHMENT

Dozer Blade
Push plate
5 tooth front scarifier
6 additional teeth for the front ripper
Dozer blade float electrovalve
Front counter weight
Lighting on dozer blade

BLADE

3,658 x 622 x 22 mm blade
3,962 x 671 x 22 mm blade
4,267 x 671 x 22 mm blade

-304.8 mm right blade extension

-304.8 mm left blade extension

REAR ATTACHMENT

Medium ripper with 3 large teeth and 5 small teeth
2 additional large teeth and 4 additional small teeth
Rear pull hook
Support for lifting the machine

WORK LIGHTS

2 work lights behind the blade
2 work lights mounted in front of the moldboard
2 work lights on the front attachment

LOCK/FL OATING/ANTI-SHOCK -MOLDBOARD AND CIRCLE

Moldboard lifting cylinder lock valve
Moldboard float electrovalve (includes the lock valve)
Anti-shock electrovalve with 2 accumulators for the moldboard
Anti-shock electrovalve with 3 accumulators for the moldboard and circle

SEAT / SEATBELT

Extra quality vinyl mechanical suspension seat
Mechanical suspension fabric seat
Pneumatic mechanical suspension fabric seat
(3") 76.5 mm seatbelt

OPTIONAL EXTRAS

Revolving safety light

Luxury toolbox

Toolbox without tools, with support, mounted on the rear frame
Slow movement symbol
Electric pump for filling tires
Support for spare tire

TIRES AND MOUNTED RIMS

TUBELESS TIRES

9" Rim - single piece/14x24 tire-12L-G2
10" Rim - 3 pieces / 14x24 tire - 12L - G2
13" Rim - single piece / 17.5x25 tire - 12L - L2

14" Rim - 3 pieces / 17.5x25 tire - 16L - L3

TIRES WITH TUBES

9" Rim - single piece / 14x24 tire - 12L - G2
10" Rim - 3 pieces / 14x24 tire - 12L - G2

RADIAL TUBELESS TIRES

9" Rim - single piece / 14x24 tire - 12L - L2
XGLA2 RADIAL

10" Rim - 3 piece / 14x24 tire - 12L - L2

XGLA2 RADIAL

RIMS

9" Rim - single piece with valve
10" Rim - 3 pieces with valve
13" Rim - single piece with valve
14" Rim - 3 pieces with valve

*All the options are subject to the local availability.



BUILDING A STRONG CASE.

Since 1842, at CASE Construction Equipment we have lived by an unwavering commitment to build practical, intuitive solutions that deliver both efficiency and productivity.

We continually strive to make it easier for our customers to implement emerging technologies and new compliance mandates.

Today, our global scale combined with our local expertise enables us to keep customers' real-world challenges at the center of our product development.

The vast CASE dealers' network is always ready to support and protect your investment and exceed your expectations, while also providing you with the ultimate ownership experience.

Our goal is to build both stronger machines—and stronger communities. At the end of the day, we do what's right for our customers and our communities so that they can count on CASE.

CASECE.com

NOTE: Standard and optional fittings can vary according to the demands and specific regulations of each country. The illustrations may include optional rather than standard fittings - consult your CASE dealer. Furthermore, CNH Industrial reserves the right to modify machine specifications without incurring any obligation relating to such changes.

Conforms to directive 2006/42/EC

creative-farm.it 05/24

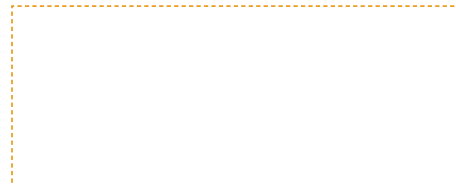



865B AWD

MOTOR GRADER
TIER 3 CERTIFIED



ENGINE - VHP

Model	FPT F4HE9687C, Tier 3 certified Compliant w/ EPA regulations effective January 2011 Electronic control
Type	4-stroke, turbocharged and air-to-air cooled
Cylinders	6-cylinder in-line
Bore/Stroke	4.09 x 5.17 in (104 x 132 mm)
Displacement	409 in ³ (6.7 L)
Fuel	Diesel
Fuel injection	Common Rail
Cooling	Liquid
Horsepower @ 2200 RPM – SAE J1995:	
Gross	193/205/220 hp (144/153/164 kW)
Net	178/190/205 hp (133/142/153 kW)
Maximum torque @ 1500 RPM:	
	612/649/686 ft-lb (830/880/930 N-m)

DRIVETRAIN

Rear axle	Graziano, planetary
Differential	Hydraulic lock, operator controlled
Inboard brakes	Wet disc
Number of discs/brake	5
Brake surface area	2,225 in ² (14 336 cm ²)
Tandems:	
Type	Welded plate
Oscillation	20° each way
Front axle	High strength, welded steel
Oscillation	15.3° each direction
Wheel lean	20° left/ right
Tires – standard	14.0 x 24 12PR TL G2 Firestone
Rims	1-piece 9 in x 24 in (227 mm x 610 mm)

Transmission type:
Direct drive countershaft Powershift
w/ electronic shift control and inching pedal

Pump flow @ 2200 RPM	29.5 gpm (112 L/min)
Sump	Integral
Speeds	8 forward/4 reverse
Shifting	Single lever, bump style automatic electronic control
Diagnostics	On-board
Speeds:	
Forward:	mph (km/h)
1st	2.7 (4.3)
2nd	3.7 (6.0)
3rd	5.2 (8.4)
4th	7.3 (11.8)
5th	10.4 (16.7)
6th	14.4 (23.1)
7th	20.2 (32.5)
8th	27.8 (44.8)
Reverse:	mph (km/h)
1st	2.5 (4.0)
2nd	5.0 (8.0)
3rd	9.8 (15.8)
4th	19.3 (31.0)

ELECTRICAL

Voltage	24 Volts, negative ground
Alternator	90 amp
Batteries	2 – Low-maintenance 1010 CCA – 100 Ah (20 hr rate)
Work lights:	
Headlights	– 2; Turn signals, front/rear;
Stop/tail	– 2; Rear mounted floods – 2;
Front mounted floods	– 2.
Backup alarm	Standard

OPERATOR ENVIRONMENT

ROPS/FOPS cab – SAE J231, ISO 3449;
Adjustable operator’s console; Adjustable cloth
suspension seat w/ 3 in (76 mm) retractable
seat belt; Safety glass; Dome light; Inside
rearview mirror; Outside rearview mirrors; Cup
holder; Storage tray; 12-volt outlet; Radio ready
– 12 Volt; Electrical master switch – automatic;
Heater/defroster/pressurizer; Air conditioner;
Sound suppression; Delphi AM/FM Radio w/ CD;
Cab doors – left/right; Steps – left/right; Steering
wheel; Windshield wiper – front; Windshield
washer – front; Sunshade.

OPERATING WEIGHT

W/ 14 ft (4.27 m) moldboard, 17.5-25 tires, front
counterweight, 175 lb (79 kg) operator
and full fuel:

	35,273 lb (16 000 kg)
Weight, front axle	11,133 lb (5 050 kg)
Weight, rear axle	24,140 lb (10 950 kg)
Blade pressure	19,048 lb (8 640 kg)

HYDRAULICS

System design	Closed center, load sensing
Hydraulic pump	Load sensing piston pump, variable displacement, pressure and flow compensated
Rated flow @ 2200 RPM	49 gpm (187 L/min)
Control valve	9 section
Side shift and pitch	Hydraulic
Saddle	5 positions
Diagnostic quick couplers	8

SERVICE CAPACITIES

Engine w/ filter change	4.4 gal (17.5 L) 4.7 gal (18.5 L)
Fuel	90 gal (341 L)
Transmission w/ filter change	5.0 gal (23 L) 6.6 gal (25 L)
Radiator	10.5 gal (40 L)
Hydraulic reservoir	24 gal (90 L)
Hydraulic system	50.2 gal (190 L)
Circle gearbox	0.75 gal (2.8 L)
Rear axle center	11.6 gal (44 L)
Total axle	11.6 gal (44 L)
Tandem case, each	18.4 gal (69 L)

OTHER SPECIFICATIONS

Steering:

Type	Hydrostatic power steering
Turns – lock-to-lock	4.75
Pump capacity @ 2200 engine RPM:	
	11.1 gpm (41.8 L/min)
Relief pressure	2,200 psi (151 bar) Integral w/ priority valve
Cylinder – 2:	
	2.0 in bore x 11.85 in stroke x 1.0 in rod dia. (50.8 mm x 301.0 mm x 25.4 mm)
Supplemental steering	Integral
Articulation:	
Type	Hydraulic actuated – w/ lock valve
Range	25° left/right
Controls	Hydraulic

MAINFRAME

Type	All welded box
Front section:	
Size	10.0 in x 11.73 in (254 mm x 298 mm)
Weight – each side	124.7 lb-ft (172.8 kg/m)
Rear section:	
Size	4.75 in x 11.75 in (121 mm x 299 mm)
Weight – each side	55.6 lb-ft (84.0 kg/m)

DRAWBAR

Type:	"A" frame welded construction with center mounted circle turn motor
Ball and circle	Shim adjustable

MOLDBOARD

Type	High-carbon steel
Shape	Involute curve
Length	14 ft 0 in (4 267 mm)
Height	23.6 in (600 mm)
Thickness	0.875 in (22 mm)
End bits	2, interchangeable
Blade pitch positions:	
Normal pitch	47°
Minimum pitch	42°
Maximum pitch	87°
Blade shift:	
Right	27.0 in (686 mm)
Left	20.9 in (533 mm)
Max. bank cutting angle:	
Right	90°
Left	90°
Max. ground penetration	28 in (711.2 mm)
Max. lift above ground	17.5 in (445 mm)

CIRCLE

Type	Welded construction
Diameter:	
Max. outside	69.0 in (1 752 mm)
Vertical member	63.0 in (1 600 mm)
Rotation	360°
Speed	1.2 RPM (7.2°/second)
Drive	Hydraulic motor
Type	Roller geroter
Displacement	15.26 in ³ /Rev. (0.25 L/Rev.)
Rated hydraulic flow	19.8 gpm (75 L/min)

ATTACHMENTS

SCARIFIER

Type	Front mounted
Width of cut	46 in (1 168 mm)
Teeth	5
Optional	11
Tooth spacing	9.0 in (229 mm)
Optional	4.5 in (114 mm)
Lift above ground	20.75 in (527 mm)
Max. penetration	12.5 in (318 mm)
Weight	1,256 lb (570 kg)
	Includes front attachment group

PUSH BLOCK

Type	Front mounted
Weight	1,084 lb (492 kg)

REAR RIPPER

Type	Parallel
Ripper teeth	3
Optional	5
Scarifier teeth	5
Optional	9
Width of cut	92.13 in (2 340 mm)
Lift above ground:	
Ripper teeth	20.38 in (518 mm)
Scarifier teeth	27.67 in (703 mm)
Max. penetration:	
Ripper teeth	17.22 in (437 mm)
Scarifier teeth	9.43 in (252 mm)
Weight	1,874 lb (850 kg)

DOZER BLADE

Type	Front mounted
Width	109 in (2 762 mm)
Height	37.5 in (953 mm)
Lift above ground	24.5 in (622 mm)
Penetration	6.5 in (165 mm)
Weight	2,568 lb (1 165 kg)
	Includes front attachment group

DOZER BLADE

Type	Front mounted
Weight	1,084 lb (492 kg)

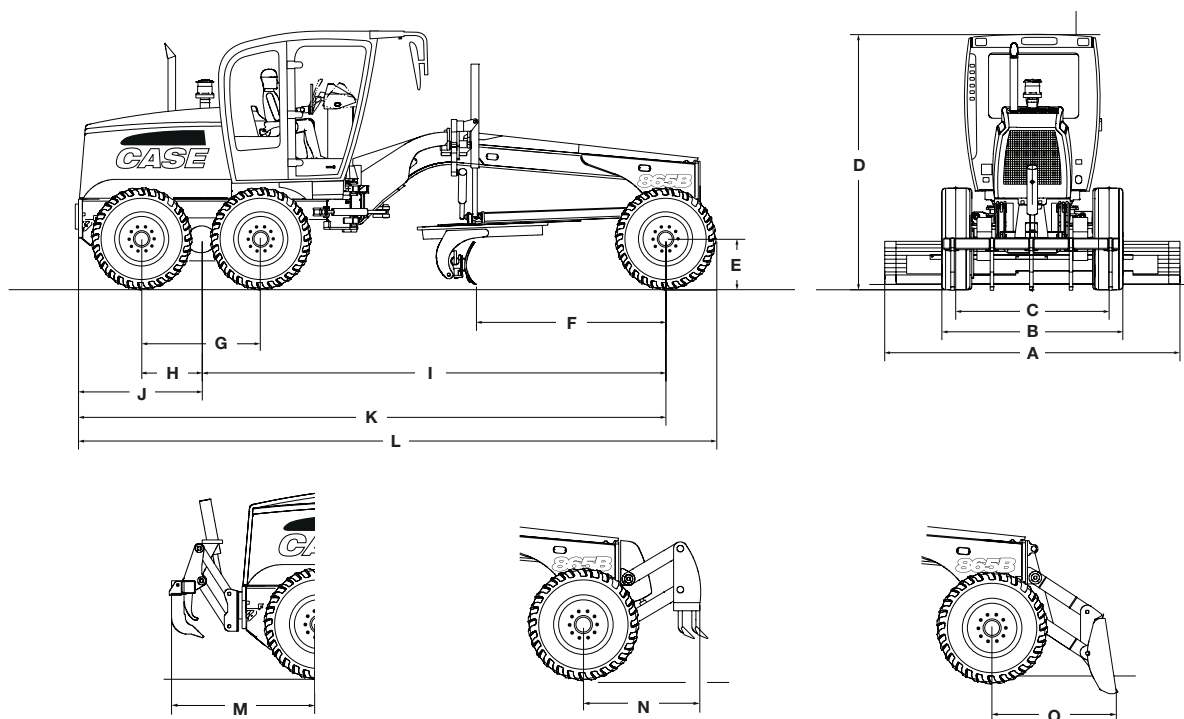

Line drawings are for illustrative purpose only and may not be exact representation of unit.

DIMENSIONS

A. Blade width	14 ft 0 in (3 962 mm)
B. Distance between outside edges of tires	8 ft 2 in (2 452 mm)
C. Wheel tread – rim 9 x 24 – one piece rim	6 ft 10 in (2 106 mm)
D. Height to top of cab – low profile	10 ft 4 in (3 150 mm)
E. Tire radius – when static	2 ft 0 in (610 mm)
F. Blade base	8 ft 5 in (2 562 mm)
G. Distance between tandem axles	5 ft 2 in (1 594 mm)
H. Distance between tandem center and wheel	2 ft 7 in (797 mm)
I. Wheelbase	20 ft 5 in (6 219 mm)
J. Distance between tandem center and rear end of machine	5 ft 5 in (1 650 mm)
K. Distance between front axle and rear end of machine	25 ft 10 in (7 869 mm)
L. Overall length – without ripper or front attachment	28 ft 0 in (8 534 mm)
M. Distance between rear tires and rear ripper	6 ft 8 in (2 028 mm)
N. Distance between front tires and front scarifier	5 ft 0 in (1 520 mm)
O. Distance between front tires and front dozer blade	5 ft 4 in (1 626 mm)
Outside tire turning radius	23 ft 9 in (7 250 mm)
Ground clearance – rear axle	24.5 in (622 mm)
Ground clearance – front axle	24.5 in (622 mm)

NOTE: All units equipped with 14.0 x 24-10 PR tires, ROPS cab with heater and A/C, std. battery, full fuel, 175 lb (79 kg) operator. Specifications per ISO 7134.

STANDARD EQUIPMENT

OPERATOR ENVIRONMENT

See page 1

ENGINE

FPT F4HE9687C turbocharged diesel
Tier 3 certified
Temperature controlled cooling fan
Charge air cooler
Air intake grid heater
Common rail electronic fuel injection
Hydraulic driven cooling fan
Auto idle

DRIVETRAIN

Hydraulic differential lock

HYDRAULICS

Closed center, load sensing hydraulic system
Controls for all functions
9 section control valve
Hydraulic moldboard side shift and pitch
5-position saddle
14 ft x 23.6 in (4 267 x 600 mm) moldboard
Moldboard Float Control
8 hydraulic diagnostic quick couplers
Front and rear piping for hydraulic attachment

OPTIONAL EQUIPMENT

MOLDBOARD

12 ft x 22 in (3 658 x 559 mm), involute curve
13 ft x 23.6 in (4 267 x 600 mm), involute curve
Extensions – 2 ft (610 mm)
Front Float Control
Lift cylinder/side shift accumulators
Lift cylinder accumulators

OPERATOR ENVIRONMENT

Front windows openable with rear window defroster
Lower front wiper/washers
Rear windshield washer
Air suspension seat

TIRES

14.0 x 24-12 PR

INSTRUMENTS

Analog displays/Gauges:
Fuel level; Engine coolant temperature;
Transmission oil temperature;
Hydraulic oil temperature.
Monitor Functions:
Hour meter; Engine speed; Travel speed; Current gear selection; FNR indication; Clock; Trip computer; Fuel consumption; Fuel level percentage; Oil pressure; Coolant temperature; Engine oil temperature; Transmission oil temperature; Hydraulic oil temperature; Turbocharger oil temperature; Differential lock indicator; Gear selection indicator; Engine diagnostics; Transmission diagnostics; System voltage; Error reporting; Warning prompts; Indicator warning lamps – main warning, parking brake, low brake pressure, high beams, turn signals, hazard lights, low fuel.

ELECTRICAL

2 – Heavy-duty batteries – 1010 CCA
Electronic Systems Monitor
Horn
Alternator – 90 amp
Backup alarm
Headlights
2 – Turn signals front
2 – Tail lights with turn signals, brake lights
Flood lights – cab mounted

TELEMATICS

CASE SiteWatch™ Telematics – includes hardware and a 3-yr Advanced data subscription

TIRES

13.0 x 24-12 PR
14.0 x 24-10 PR
14.0 x 24-12 PR
14.0 x R24 XGLA radial
14.0 x R24 Snoplus
16.0 x 24-12 PR
17.5 x 25-12 PR
17.5 x 25-16 PR
17.5 x R25 XTLA radial
17.5 x R25 Snoplus

ELECTRICAL

2 – Front mounted working lights
2 – Floodlights at moldboard
2 – Floodlights at articulation
Snow plow lighting package

OTHER

Bidirectional engine cooling fan
Cold weather package
Fire extinguisher
Strobe light
Tool box – without tools
Deluxe tool box – with tools
Tire inflator kit
Spare wheel
Spare wheel support
Slow moving vehicle sign
Rear pull hook

ATTACHMENTS

Front pull hook
Front counterweight
Front dozer blade
Front scarifier
Front push plate
Front support and lift cylinder
Rear ripper

CaseCE.com

©2017 CNH Industrial America LLC. All rights reserved. CASE is a trademark registered in the United States and many other countries, owned by or licensed to CNH Industrial N.V., its subsidiaries or affiliates. CNH Industrial Capital is a trademark in the United States and many other countries, owned by or licensed to CNH Industrial N.V., its subsidiaries or affiliates. Printed in U.S.A. Contains 10% post-consumer fiber.

IMPORTANT: CASE Construction Equipment Inc. reserves the right to change these specifications without notice and without incurring any obligation relating to such change. Availability of some models and equipment builds vary according to the country in which the equipment is used. The illustrations and text may include optional equipment and accessories and may not include all standard equipment. Your CASE dealer/distributor will be able to give you details of the products and their specifications available in your area.



CASE Construction Equipment is biodiesel-friendly. NOTE: All engines meet current EPA emissions regulations. All specifications are stated in accordance with SAE Standards or Recommended Practices, where applicable.



Always read the Operator's Manual before operating any equipment. Inspect equipment before using it, and be sure it is operating properly. Follow the product safety signs and use any safety features provided.

Form No. CCE201701865BAWD
Replaces Form No. CCE201503865BAWD

865B AWD

4 of 4

M^cINTOSH & SON



Liugong 4230D Motor Grader QUOTATION

For: Shire of Quairading
Date: 30/9/2024
Attention: Sarah Caporn

By: McIntosh & Son
547 Great Eastern Hwy, Redcliffe, WA
From: Richard Gainsford
Contact: 0438 383 517
R.Gainsford@mcsn.com.au



MCINTOSH GROUP

LEADING AUSTRALIAN MACHINERY GROUP

For more than 60 years, the McIntosh Group has set the benchmark in equipment management solutions, providing unrivalled support in the agricultural, construction and grounds care machinery industries.

Having grown to employ over 600 people Australia wide, our decision makers remain in the frontline – ensuring we deliver and nurture our service-first culture.

Our aim is to build a continuously improving stable of products and services which will help our customers achieve their objectives. In turn, this will drive our business and create opportunities for employee growth, resulting in recognition both as an industry employer and an equipment supplier of choice.

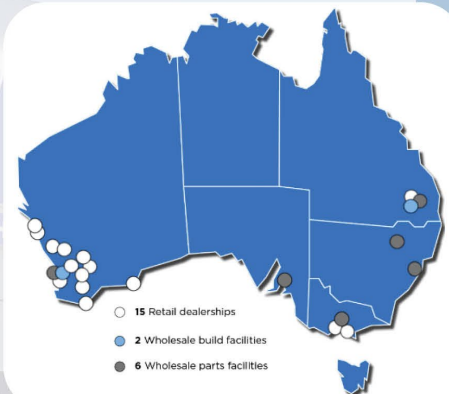

MCINTOSH & SON

Since 1955, McIntosh & Son has been a leading Australian dealership group specialising in agricultural, construction and grounds care machinery with 12 locations located across WA and QLD.

McIntosh & Son is committed to providing customers with comprehensive and exceptional service, and as a result, has developed an enviable reputation as a trusted, respected and reputable machinery dealership.

PURCHER INTERNATIONAL

Purcher International has been a leading supplier of farm machinery and transport equipment to the Midwest region of Western Australia since 1967.

From its dealership in Geraldton, Purcher International supports leading brands including Case IH, Freightliner, Mercedes-Benz Trucks and Fuso.

CASE VIC

Case Vic is a construction machinery retail and rental dealership business.

Servicing Victoria from 2 strategic locations in Dandenong and Truganina, Case Vic has provided the construction industry with sales, parts, product support and rental equipment since 2000.

MCINTOSH DISTRIBUTION

Established in 1993, McIntosh Distribution is an Australian machinery importer and wholesaler with an extensive 140+ dealer network serviced by build facilities and parts depots across Australia.

With a focus on providing excellent customer service, McIntosh Distribution aims to provide farmers, growers and dealerships with industry-leading equipment, parts, service and after-sales support.

MCINTOSH CE

McIntosh CE began in 2021, as McIntosh Group were appointed Australian distributors for Case Construction Equipment.

Responsible for all aspects of Case Construction Equipment across Australia, McIntosh CE supports their dealer network with sales, marketing, product support and parts.

MCINTOSH TRAINING ACADEMY

McIntosh & Son has invested in the future education of our industry by becoming a Registered Training Organisation – McIntosh Training Academy – and developing an in-house apprenticeship program where students can benefit from a dynamic learning environment in our world-class facilities.



McINTOSH & SON PERTH



Our pursuit of excellence and continuous improvement has resulted in us being the supplier of choice for leading national and international products.

McIntosh & Son are dealers for over 100 machinery brands, including;



PARTS

Our parts department is staffed by experienced and skilled personnel so you receive professional service and advice.

We also stock a range of genuine and factory-direct parts including:



WORKSHOP & FIELD SERVICE

Our service department has a comprehensive team of technicians, auto-electricians, fabricators and apprentices, all committed to delivering the best service.

We offer all aspects of servicing, repairs, maintenance, electrical and hydraulic repairs, machinery inspection and air-conditioning, designed to keep your machinery in optimal condition.



Quote No.:RG0746

Revision No.: 01

Quotation

30th September 2024

Dear Sarah Caporn,

We thank you for the opportunity to present McIntosh & Son and our proposal for the equipment listed overleaf.

Our primary goal is to promote, sell and support the products we represent and to provide equipment supply and service solutions to customers wanting more flexibility and innovation.

Our growth and diversification into new areas has continued to strengthen the company, which operates through a talented and cohesive management team and dedicated staff. We continually strive to provide superior service and offer a quality product range to accommodate the needs of our customers.

The McIntosh & Son sales team has a wealth of experience and knowledge across our machinery range. Our service team aim to deliver the best assistance to keep your construction, grounds care and agricultural machinery in optimal condition. We stock a wide range of parts and accessories, and our parts staff can assist with ensuring you get the right parts when you need them.

Should you require finance, our relationship with PTR Asset Finance can help with a wide range of financial services that are customised and flexible. They have the expertise to deal with your next equipment purchase, and pride themselves on keeping up with industry movements to provide competitive solutions for your business. They can be contacted at their offices in Osborne Park on 08 9322 1229.

We hope that the quotation provided overleaf meets with your approval, and we are always available for further discussion.

Yours sincerely,

Richard Gainsford
Construction Sales
McIntosh & Son
0438 383 517



McIntosh Holdings Pty Ltd ABN 28 008 675 876 T/AS McIntosh & Son
547 Great Eastern Highway REDCLIFFE WA 6104 T: (08) 9475 1600
www.mcintoshandson.com.au perth@mcson.com.au



Quote No.:RG0746

Revision No.: 01

Quote date: 30th September 2024

Quote expiration date: 30th November 2024

Prepared by

Richard Gainsford
 Mob: 0438 383 517
 Email: R.Gainsford@mcson.com.au

Equipment	Quantity	Quoted Price (exc. GST)
Liugong 4230D Motor Grader	1	\$362,300.00

Specifications

Please see attached brochure for detailed specifications

Machine Features

- 241hp Cummins QSL9.3 Tier 3 diesel engine – no AdBlue
- Bi-directional hydraulic reversable cooling fan
- Cyclone pre-cleaner
- 40km/h travel speed
- 6F/3R speed auto shifting Powershift transmission electronically controlled
- 4 Wheel drive
- 18,340 kg operating weight
- 14FT multi-radius moldboard with blade float
- Wet type inboard, adjustment free brakes
- Ground access service points
- Hydraulic diff lock
- 17.5Rx25 tires on 10x24” rims

Blade

- 14ft blade width
- 610mm blade height
- 22.2mm blade thickness
- End bits overlay
- Joystick hand controls
- Slope Meter (In cab)
- Blade float system

Attachments

- Rear ripper/scarifier with 5 ripper shanks & 9 scarifier tines
- Front and rear tow points
- 500kg Push block mounted to front of the machine



McIntosh Holdings Pty Ltd ABN 28 008 675 876 T/AS McIntosh & Son
 547 Great Eastern Highway REDCLIFFE WA 6104 T: (08) 9475 1600
www.mcintoshandson.com.au perth@mcson.com.au



Quote No.:RG0746

Revision No.: 01

Operator Station

All necessary instrumentation/gauges including hazard warning system
Joystick controls
Articulation and slope indicators
Sound suppression
Hour meter
Reverse camera
Integrated HVAC air conditioning with pre cleaner
Darkest legal tinted windows
Rear window wiper washer
Rear window defroster
Sunshade
External mounted rearview mirrors
Fully adjustable air suspension seat
Canvas seat cover
Seat belt
Rubber floor mat
AM/FM stereo radio with Bluetooth connectivity
80 channel UHF radio

Electrical

2x LED Beacons on roof
High & low headlights
Lights: Front – 2 x Headlight, 2 x Cab, 2 x Blade
Rear – 2x Work lights
Lockable Battery Isolator
In Cab 12V Power Source
External jump start points
2x E-stops

General details

9kg fire extinguisher
Front light guarding
Transmission guard
Battery isolator
Two (2) sets of keys
Operator Manual
Large toolbox fitted to A-Frame
Fuel tank capacity 348L
12V Air compressor for tire filling
Sign writing "Shire of Quairading" in prominent position each side of machine.

Registration & Delivery

Registered on the Shire of Quairading Bulk license
Delivery to Shire of Quairading depot



McIntosh Holdings Pty Ltd ABN 28 008 675 876 T/AS McIntosh & Son
547 Great Eastern Highway REDCLIFFE WA 6104 T: (08) 9475 1600
www.mcintoshandson.com.au    perth@mcson.com.au



Quote No.:RG0746

Revision No.: 01

Warranty

2 years / 3000 hrs

Pricing

Liugong 4230D Motor Grader	Selling Price Excluding GST	\$362,600.00
	GST Component	\$36,230.00
Selling Price Including GST		\$398,530.00
Less trade in of 2014 CAT 12M Motor Grader	Inc GST	\$244,200.00
Total Change Over Price	Inc GST	\$154,330.00

Optional Extras pricing (ex GST)

- 2D Grade control system with automatics (same as non-GPS CAT grade system) \$32,150.00
- 3D grade control system with automatics (same as GPS CAT grade system) \$78,600.00
- Groeneveld Twin Pump Auto Greaser 8kg \$18,230.00

Payment Terms

Payment in 30 days from invoice

Quote Validity

Pricing is subject to change without notice. Please refer to the standard terms and conditions within.

Delivery

At time of tender a Liugong 4230D grader is ex-factory. This can be made ready for delivery in 10-12 weeks from order.

Freight

Pricing include delivery and operator handover training to Shire of Quairading depot.



McIntosh Holdings Pty Ltd ABN 28 008 675 876 T/AS McIntosh & Son
 547 Great Eastern Highway REDCLIFFE WA 6104 T: (08) 9475 1600
www.mcintoshandson.com.au perth@mcson.com.au



Quote No.:RG0746

Revision No.: 01

Qualitative Criteria

Parts

Each McIntosh & Son parts department is staffed by skilled personnel with years of experience in Agricultural, Construction and Grounds Care equipment so you receive professional service and parts sourcing when a part is urgently required.

Our warehouses are stocked with genuine parts and service consumables from our suppliers. We are also agents and stockists of other quality parts suppliers. All our branches are computer linked to major suppliers to provide efficient turn arounds in the event of a breakdown.

Our parts departments offer after hours capabilities for parts ordering and dispatch.

The Shire of Murray are welcome to visit our Perth warehouse upon request

Service

Servicing will be carried out as per the manufacturer specifications. Please refer to the attached maintenance chart for servicing intervals and inclusions/exclusion.

Servicing and repairs work can be booked by contacting our branch.

Our service teams are trained to use the latest manufacturer electronic service tools, ensuring you get up and running as quickly as possible.

The McIntosh & Son service team has over 100 professionals across the state, including technicians, auto electricians, fabricators and apprentices who aim to deliver the best service to everyone and keep your farm, agricultural and construction machinery or equipment in optimal condition. Services we offer include:

- First Service
- Service and Repairs
- Air-conditioning
- Pre-season Service
- Machine inspection
- Breakdowns
- Electrical and hydraulic repairs
- Other maintenance



McIntosh Holdings Pty Ltd ABN 28 008 675 876 T/AS McIntosh & Son
547 Great Eastern Highway REDCLIFFE WA 6104 T: (08) 9475 1600
www.mcintoshandson.com.au    perth@mcson.com.au



Quote No.:RG0746

Revision No.: 01

Workshop Service

We have 12 workshops strategically located across Western Australia and Queensland to ensure your machines are always running in optimum condition. These are located in:

Western Australia (WA): Albany, Cunderdin, Esperance, Geraldton, Katanning, Kulin, Merredin, Moora, Narrogin, Perth, Wongan Hills and Queensland (QLD): Dalby.

Field Service

In addition, McIntosh & Son has a fleet of field service vehicles ready to respond quickly to assist you at your own location. The field service vehicles are well equipped to ensure your farm, agricultural and construction machinery and equipment are kept in optimal condition. Our field service capabilities are also available outside of business hours for any breakdown or urgent repair situations

Our Team

With a widespread range of knowledge, our team is here to support from sales right through to after product care. Meet some of key member of the team below:



MIKE FOSKETT

General Manager

Mike previously led the Perth team for 7 years until 2010. He returned to the dealership in the lead role after a number of years with a manufacturer.

In his role, Mike oversees all parts of the business including Sales, Service & Parts. Mike strives to deliver a customer-centric approach while supporting staff to ensure they can focus on providing excellent customer service.



McIntosh Holdings Pty Ltd ABN 28 008 675 876 T/AS McIntosh & Son
 547 Great Eastern Highway REDCLIFFE WA 6104 T: (08) 9475 1600
www.mcintoshandson.com.au perth@mcson.com.au



Quote No.:RG0746

Revision No.: 01



ANDREW CALVERT

Service Manager

Andrew brings with him a wealth of knowledge from the service and mining industries, with roles such as mine fire & rescue, industrial paramedic, mine site medic and most recently, service and workshop manager looking after Case Construction machinery.

Andrew is the first point of contact for any service and maintenance queries.



NICK JOSE

Parts Manager

Nick came onboard to strengthen and grow our parts capabilities, to great success.

Nick has over 10 years leadership experience with WA leading construction supplier WesTrac.

The branch prioritises stocking a large number of parts locally in Perth, with direct access to 12 other WA dealership locations to assist with demand as needed.



RICHARD GAINSFORD

Sales - Construction

Richard has over 8-years of sales and service experience within the Local Government sector in WA through construction and turf equipment. A strong understanding of operational needs, and problem solving is what helps Richards' customers get the best needs for their fleet.

Richard is always willing to carry out any operator training and support onsite.



McIntosh Holdings Pty Ltd ABN 28 008 675 876 T/AS McIntosh & Son
 547 Great Eastern Highway REDCLIFFE WA 6104 T: (08) 9475 1600
www.mcintoshandson.com.au perth@mcson.com.au



Quote No.:RG0746

Revision No.: 01

Offer and Acceptance

If you wish to accept the quotation presented here, please sign below. Your signature constitutes an offer by you to purchase the goods on the terms and conditions set out in this document.

McIntosh and Son’s terms and conditions of sale are included herein.

Contract and Acknowledgements

SIGNING SECTION

By signing this document the Purchaser hereby confirms the accuracy of the information provided herein and agrees to the Dealer’s Terms and Conditions of Sale a copy of which is available upon request.

Executed as a deed

Signed by the Applicant

Signed by the Dealer

Signed for and on behalf of the Applicant

Signed for and on behalf of the Dealer

Name of signatory

Name of signatory

Capacity of signatory e.g. director / partner

Capacity of signatory e.g. branch manager

Date

Date



McIntosh Holdings Pty Ltd ABN 28 008 675 876 T/AS McIntosh & Son
547 Great Eastern Highway REDCLIFFE WA 6104 T: (08) 9475 1600

www.mcintoshandson.com.au perth@mcson.com.au

TERMS AND CONDITIONS OF SALE

NOTE: The Australian Consumer Law and other legislation have provisions that may not be contracted out of. Accordingly where those mandatory provisions apply, they override provisions to the contrary in these Terms and Conditions.

1. INTERPRETATION

In these Terms and Conditions unless the context otherwise requires:

- (a) a reference to a party includes a reference to the party's successors and permitted assigns and any person claiming under or through the party;
- (b) every agreement or obligation expressed or implied in this Deed by which two or more persons agree or are bound shall bind such persons jointly and each of them severally;
- (c) a reference to a group of persons includes a reference to all of them collectively, any two or more collectively and each of them individually;
- (d) a reference to the Agreement includes these Terms and Conditions of Sale;
- (e) "ACL" means the Australian Consumer Law Schedule of the Competition and Consumer Act 2010 (Cth) as amended.
- (f) "Purchaser" means the party or parties defined as the Purchaser in the Agreement.;
- (g) "Authorised Representative" means the Dealer's Branch Manager or such person as may be authorised by the Dealer from time to time;
- (h) "the Dealer" means McIntosh Holdings Pty Ltd (ABN 28 008 675 876) (ACN 008 675 876) trading as McIntosh and Son WA;
- (i) "Conditions"/"Terms"/"Terms and Conditions" or similar expressions means these Terms and Conditions of Sale forming part of the Agreement;
- (j) "consumer" is as defined in the ACL and in determining if the Purchaser is a consumer, the determination is made if the Purchaser is a consumer under the Agreement.
- (k) "goods" means goods supplied or ordered under this Agreement
- (l) "GST" means the goods and services tax as imposed by the GST Law together with any related interest, penalties, fines or other charge.
- (m) "GST Law" has the meaning given to that term in A New Tax System (Goods and Services) Act 1999 (Cth) as amended.
- (n) "including" and similar expressions means "including, but not limited to";
- (o) "Person" includes an individual, the estate of an individual, a body politic, a corporation, an association (incorporated or unincorporated) and a statutory or other authority.
- (p) "PPSA" means the Personal Property Securities Act 2009 (Cth) as amended.
- (q) "Purchase Price" means the price for the goods or services set out in the Agreement, Quotation or Dealer's invoice.
- (r) "Quotation" means the form of quotation submitted by the Dealer to the Purchaser in which these Terms are deemed to be incorporated.
- (s) "services" means services supplied by the Dealer to the Purchaser.
- (t) "Special Goods" means any goods which are, at the Purchaser's request, embellished, machined, cut-to-size or specifically modified for the Purchaser.

2. STATEMENTS

- 2.1 A document signed by the Authorised Representative indicating the amount owing by the Purchaser is prima facie evidence of that amount owing, except in the case of manifest error.
- 2.2 Payment for Goods and/or Services is due in accordance with these Terms and Conditions of Sale.

3. REPRESENTATIONS

The Purchaser (and the Directors and Partners of the Purchaser, if applicable) warrants as to the correctness of the information which it has furnished to the Dealer in this Agreement, and acknowledges that the Dealer has relied upon this information in determining whether or not to enter into this Agreement.

4. CHARGE

- 4.1 The Purchaser charges all its right, title and interest in any land that it owns currently or may acquire in the future solely or jointly or have or become to have a beneficial interest in, in favour of the Dealer, with due and punctual observance of all of the obligations of the Purchaser under the Agreement.
- 4.2 The Purchaser indemnifies the Dealer against all expenses and legal costs (on an indemnity basis) for preparing, lodging and removing any caveat.
- 4.3 The Purchaser hereby acknowledges that the Dealer may at its discretion register and lodge an absolute caveat(s) on such property or properties in respect of the interest conferred on it under this clause 6. Such registration of a caveat by the Dealer over the Purchaser's property or properties must not be challenged by the Purchaser in any way whatsoever, and the Purchaser agrees not to take any steps in filing a "lapsing notice" via the Land Titles Office to have the caveat removed, until such time that the Purchaser has paid all monies owing by it to the Dealer as claimed from time to time.

5. ASSIGNMENT

The Purchaser must not assign or transfer any of its rights or obligations in connection herewith to any other person whatsoever.

6. CHANGE IN CONTROL

- 6.1 The Purchaser must advise the Authorised Representative in writing no later than fourteen (14) days before a charge in effective control of the Purchaser or of any change or alteration of any particulars contained in this Agreement (if applicable).
- 6.2 The Dealer (upon receipt of such advice) is entitled to review the Agreement and in its sole discretion, to terminate the Agreement upon seven (7) days written notice (the "Notice Period") to the Purchaser.
- 6.3 In such circumstances, the Dealer is entitled to payment by the Purchaser of a sum equal to the cost of Goods and/or Services then unpaid by the Purchaser upon expiry of the Notice Period. The Purchaser shall indemnify the Dealer in respect of any loss arising from the Purchaser's failure to so notify.
- 6.4 If the Purchaser signs the Agreement as the trustee of any trust (the "Trust"), the Purchaser is personally liable for the performance of all covenants contained in the Agreement and agrees that the Dealer's right of recourse pursuant to this Agreement shall not be limited to the Purchaser's assets but shall extend to the assets of the Trust.

7. GOVERNING TERMS AND CONDITIONS

These are the only Terms which are binding upon the Dealer with the exception of those otherwise agreed in writing by the Dealer or which are imposed by a statute and which cannot be excluded. Any direction by the Purchaser either verbal or written to procure goods or services from the Dealer will be deemed as acceptance by the Purchaser of these Terms, despite any provisions to the contrary in the direction or any purchase order issued by the Purchaser.

8. TERMS OF PAYMENT

- (a) The Purchaser must pay the Purchase Price in full prior to delivery of the goods and/or services.
- (b) The Purchaser is not entitled to make any deduction from amounts owing to the Dealer in respect of any set off or counterclaim to be held back for retention.
- 9. PAYMENT DEFAULT**
- (a) If the Purchaser defaults in payment by the due date of any amount payable to the Dealer then all money which would become payable by the Purchaser to the Dealer at a later date on any account, becomes immediately due and payable without the requirement of any notice to the Purchaser, and the Dealer may, without prejudice to any of its other accrued or contingent rights:
- (i) charge the Purchaser interest on any sum due at the prevailing rate of 15% per annum for the period from the due date until the date of payment in full;
- (ii) charge the Purchaser for, and the Purchaser must indemnify the Dealer from, all costs and expenses (including without limitation indemnity legal costs) incurred by it resulting from the default or in taking action to enforce compliance with the Agreement or to recover any goods;
- (iii) cease or suspend supply of any further goods or services to the Purchaser;
- (iv) by written notice to the Purchaser, terminate any uncompleted contract with the Purchaser.
- (b) Clause 9(a) may also be relied upon, at the Dealer option:
- (i) where the Purchaser is a natural person and becomes bankrupt or enters into any scheme of arrangement or any assignment or composition with or for the benefit of his or her creditors or any class of his or her creditors generally; or
- (ii) where the Purchaser is a corporation and it enters into any scheme of arrangement or any assignment or composition with or for the benefit of its creditors or any class of its creditors generally, or has a liquidator, administrator, receiver, manager or similar functionary appointed in respect of its assets, or any action is taken for, or with the view to, the liquidation (including provisional liquidation), winding up or dissolution without winding up of the Purchaser.
- 10. INSPECTION AND ACCEPTANCE**
- (a) If the Purchaser is a consumer, nothing in these Terms and Conditions limits any remedy available pursuant to the ACL save as permitted under the ACL.
- (b) The Purchaser must inspect all goods upon delivery and within 48 hours of delivery give written notice with full details and description to the Dealer named in the relevant Sales Invoice if the Purchaser alleges that the goods are not in accordance with the Purchaser's order. Failing such notice, the goods shall be deemed to have been delivered to and accepted by the Purchaser.
- (c) When any non-compliance with the Purchaser's order is accepted by the Dealer, the Dealer may, at its option, replace the goods, or refund the price of the goods.
- 11. RETURNS**
- Unless otherwise agreed, returns other than required pursuant to the ACL must be approved by the Dealer named in the relevant Sales Invoice. These authorised returns must be freight prepaid and will only be accepted if they are in a saleable condition. The Dealer reserves the right to charge a handling fee [equal to 10% of the price of the goods] for goods returned under this provision. Unless required by the ACL, Special Goods are not returnable.
- 12. QUOTATIONS**
- (a) Unless previously withdrawn, a Quotation is valid for 30 days or such other period as stated in it whichever period is the lesser. A Quotation is not to be construed as an obligation to sell or provide services but merely an invitation to treat and no contractual relationship shall arise from it until the Purchaser's order has been accepted in writing by the Dealer.
- (b) The Dealer is not bound by any conditions attaching to the Purchaser's order or acceptance of a Quotation and, unless such conditions are expressly accepted by the Dealer in writing, the Purchaser acknowledges that the Purchaser's conditions are expressly negated.
- (c) Every Quotation is subject to and conditional upon obtaining any necessary import, export or other licence.
- 13. PRICING**
- The parties agree that the Purchase Price does not include GST unless otherwise stated.
- 14. PASSING OF PROPERTY AND RISK**
- (a) Goods supplied by the Dealer to the Purchaser shall be at the Purchaser's risk immediately upon delivery to the Purchaser, into the Purchaser's custody or at the Purchaser's direction (whichever happens first). The Purchaser shall insure the goods from the time of that delivery at its cost against such risks as it thinks appropriate, shall note the interest of the Dealer on the insurance policy and shall produce a certificate to this effect to that Seller upon request.
- (b) Property in the goods supplied by the Dealer to the Purchaser under these Terms shall not pass to the Purchaser until those goods and other goods have been paid for in full.
- (c) Until the Dealer receives full payment in cleared funds for all goods and services supplied by it to the Purchaser, as well as all other amounts owing to the Dealer by the Purchaser:
- (i) the Purchaser shall store the goods in a manner which shows clearly that they are the property of the Dealer; and
- (ii) the Purchaser may sell the goods in the course of its business and shall account to the Dealer for the proceeds of sale (including any proceeds from insurance claims). These proceeds must be kept in a separate bank account with a bank to whom the Purchaser has not given security however failure to do so will not affect the Purchaser's obligations as trustee.
- (d) In addition to the Dealer's rights under the PPSA, the Purchaser irrevocably authorises the Dealer at any time to enter onto any premises upon which:
- (i) the Dealer's goods are stored to enable the Dealer to inspect the goods and/or if the Purchaser has breached these Terms, reclaim the goods;
- (ii) the Purchaser's records pertaining to the goods are held to inspect and copy such records.
- (e) The Purchaser and the Dealer agree that the provisions of this clause apply notwithstanding any arrangement under which the Dealer grants credit to the Purchaser.
- 15. PERSONAL PROPERTY SECURITIES ACT**
- (a) Notwithstanding anything to the contrary contained in these Terms, the PPSA applies to these Terms.
- (b) For the purposes of the PPSA:
- (i) terms used in this clause 15 that are defined in the PPSA have the same meaning as in the PPSA;
- (ii) these Terms are a security agreement and the Dealer has a Purchase Money Security Interest in all present and future goods supplied by the Dealer to the Purchaser and the proceeds of the goods;
- (iii) the security interest is a continuing interest irrespective of whether there are monies or obligations owing by the Purchaser at any particular time; and

- (iv) the Purchaser must do whatever is necessary in order to give a valid security interest over the goods and their proceeds which is able to be registered by the Dealer on the Personal Property Securities Register.
- (c) The security interest arising under this clause 15 attaches to the goods when the goods are collected or dispatched from the Dealer's premises and not at any later time.
- (d) Where permitted by the PPSA, the Purchaser waives any rights to receive the notifications, verifications, disclosures or other documentation specified under sections 95, 118, 121(4), 130, 132(3)(d), 132(4), 135 and 157 of the PPSA.
- (e) The Dealer and the Purchaser agree to contract out of and nothing in the provisions of sections 96, 125, 129, 142 and 143 of the PPSA will apply to these Terms.
- (f) To the extent permitted by the PPSA, the Purchaser agrees that:
 - (i) the provisions of Chapter 4 of the PPSA which are for the benefit of the Purchaser or which place obligations on the Dealer will apply only to the extent that they are mandatory or the Dealer agrees to their Agreement in writing; and
 - (ii) where the Dealer has rights in addition to those in Chapter 4 of the PPSA, those rights will continue to apply.
- (g) The Purchaser must immediately upon the Dealer's request:
 - (i) do all things and execute all documents necessary to give effect to the security interest created under this Agreement; and
 - (ii) procure from any person considered by the Dealer to be relevant to its security position such agreements and waivers (including as equivalent to those above) as the Dealer may at any time require.
- (h) The Dealer may allocate amounts received from the Purchaser in any manner the Dealer determines, including in any manner required to preserve any Purchase Money Security Interest it has in goods supplied by the Dealer.

16. SUPPLY

The Dealer reserves the right to suspend or discontinue the supply of goods to the Purchaser without being obliged to give any reason for its action.

17. PART DELIVERIES

The Dealer reserves the right to make part deliveries of any order, and each part delivery shall constitute a separate sale of goods upon these Terms. A part delivery of an order shall not invalidate the balance of an order.

18. DIMENSIONS, PERFORMANCE DATA AND OTHER DESCRIPTIVE DETAILS

If the Purchaser is a consumer, nothing in this clause limits any remedy available pursuant to the ACL save to the extent permitted. To the greatest extent permitted by law:

- (a) Photographs, drawings, illustrations, weights, dimensions and any other particulars accompanying, associated with or given in a Quotation, descriptive literature or a catalogue approximate the goods offered but may be subject to alteration without notice.
- (b) Any performance data provided by the Dealer or a manufacturer is an estimate only and should be construed accordingly.
- (c) Unless agreed to the contrary in writing, the Dealer reserves the right to supply an alternative brand or substitute product when necessary or appropriate.

19. SHIPMENT AND DELIVERY

- (a) The means of delivery is at the Dealer's sole discretion.
- (b) If the Dealer directs the Purchaser to collect the goods:
 - (i) the Purchaser must collect the goods within 7 days of being advised they are ready;
 - (ii) if the Purchaser does not collect the goods within this time, the Purchaser is deemed to have taken delivery of the goods and is liable for commercial storage charges payable to the Dealer monthly on demand.
- (c) The Purchaser must pay to the Dealer on demand any delivery costs incurred by the Dealer if
 - (i) the Purchaser requests another method of delivery from that outlined in (a) above; or
 - (ii) the Purchaser elects to use an independent courier to deliver the goods and enters into a separate contract with that independent courier to deliver the goods.

20. MANUFACTURERS' CHANGES

To the greatest extent permissible under law where the Dealer is acting as agent for a manufacturer, the Dealer shall not be liable for any alteration or variation in the goods made by the manufacturer.

21. CURRENCY

Where goods are imported into Australia, any adverse variation in the price arising from fluctuation in exchange rates between the date of the Purchaser's order and the date of payment by the Dealer will be to the Purchaser's account.

22. CONTINGENCIES

Any charge, duty, impost, sales tax or other expenditure which is not applicable at the date of Quotation or invoice but which is subsequently levied upon the Dealer in relation to a Quotation or Sales Invoice as a result of the introduction of any legislation, regulation or governmental policy, shall be to the Purchaser's account.

23. CHARGES BEYOND POINT OF DELIVERY QUOTED

Unless otherwise agreed in writing, if the Dealer prepays freight, insurance, custom and import duties (if any), landing and delivery charges and all other charges in connection with shipment and delivery of the goods, then any such charges shall be to the Purchaser's account.

24. FORCE MAJEURE

If the Dealer's performance or observance of any obligations is prevented, restricted or affected by reason of a force majeure event including strike, lock out, industrial dispute, raw material shortage, breakdown of plant, transport or equipment or any other cause beyond the Dealer's reasonable control, the Dealer may, in its absolute discretion give prompt notice of that cause to the Purchaser. On delivery of that notice the Dealer is excused from such performance or observance to the extent of the relevant prevention, restriction or effect.

25. DEALER'S CANCELLATION

- (a) If the Dealer is unable to deliver the goods, then it may cancel the Purchaser's order (even if it has been accepted) by written notice to the Purchaser and limits its liability to the Purchaser in that regard to the greatest extent permitted under law.
- (b) If the Purchaser commits a breach of its obligations under the Agreement, then the Dealer may, without prejudice to any other rights or remedies terminate the Agreement and seek damages for any loss suffered.

26. PURCHASER'S CANCELLATION

- (a) To the greatest extent permitted under law, the Purchaser shall have no right to terminate the Agreement or cancel an order which has been accepted by the Dealer unless otherwise agreed in writing. If a right of cancellation is granted to the Purchaser, such right of cancellation must be exercised in accordance with the relevant terms of cancellation and by notice in

writing from the Purchaser to the Dealer with which the order has been placed not later than 7 days prior to the estimated date of shipment by the manufacturer or that Seller as the case may be.

(b) Unless otherwise agreed between the Purchaser and Seller, upon cancellation prior to shipment any deposit paid by the Purchaser shall be forfeited to the manufacturer or Seller (as the case may be).

(c) Despite the cancellation of any order for any reason, the Purchaser must still purchase from the Dealer any goods ordered by the Purchaser which constitute Special Goods (whether in store, in transit or being manufactured) which were procured or ordered by the Dealer before such cancellation, unless otherwise agreed in writing by the Dealer.

27. WARRANTY AND LIABILITY OF SELLER

(a) The Dealer makes no express warranties under these Terms.

(b) Except as the Terms specifically state, or as contained in any express warranty provided in relation to the goods or services, the Agreement does not include by implication any other term, condition or warranty in respect of the quality, merchantability, acceptability, fitness for purpose, condition, description, assembly, manufacture, design or performance of the goods or services or any contractual remedy for their failure.

(c) If the Purchaser is a consumer nothing in these Terms restricts, limits or modifies the Purchaser's rights or remedies against the Dealer for failure of a statutory guarantee under the ACL save as permitted under the ACL.

(d) If the Purchaser on-supplies the goods to a person who is a consumer, or uses up or transforms the goods in the course of trade then:

(i) if the goods or services are not of a kind ordinarily acquired for personal, domestic or household use or consumption, then the amount specified in section 276A(1) of the ACL is the absolute limit of the Dealer's liability to the Purchaser;

(ii) otherwise, payment of any amount required under section 274 of the ACL is the absolute limit of the Dealer's liability to the Purchaser;

howsoever arising under or in connection with the sale, installation, use of, storage or any other dealings with the goods or services by the Purchaser or any third party.

(e) If sub clauses 27(b) and 27(c) of these Terms and Conditions do not apply, then other than as stated in the Terms and Conditions or any written warranty statement then, to the greatest extent permitted under law, the Dealer is not liable to the Purchaser in any way under or in connection with the sale, installation, use of, storage or any other dealing with the goods or services by the Purchaser or any third party.

(f) To the greatest extent permitted under law the Dealer is not liable for any indirect or consequential losses or expenses suffered by the Purchaser or any third party, howsoever caused, including but not limited to loss of turnover, profits, business or goodwill or any liability to any other party.

(g) The Purchaser expressly acknowledges and agrees that:

(i) it has not relied upon, any service involving skill and judgement, or on any advice, recommendation, information or assistance given by the Dealer, its agents or employees in relation to the goods or services or their use or purpose.

(ii) it has not made known, wither expressly or by implication, to the Dealer any purpose for which it requires the goods or services and it has the sole responsibility of satisfying itself that the goods or services as suitable for the use of the Purchaser.

28. ALTERATION TO CONDITIONS

The Dealer may, at any time and from time to time, alter these Terms and Conditions by providing notice to the Purchaser.

29. GOVERNING LAW

These Terms and Conditions shall be governed by the laws of Western Australia. The parties agree to submit to the exclusive jurisdiction of the Courts in Perth, Western Australia.

30. WAIVER

The Dealer's failure to enforce any of these Terms and Conditions shall not be construed as a waiver of any of the Dealer's rights.

31. WRITTEN NOTICE

A notice must be in writing and handed personally or sent by email, facsimile or prepaid mail to the last known address of the addressee. Notices sent by pre-paid post are deemed to be received upon posting. Notices sent by facsimile or email are deemed received on confirmation of successful transmission.

32. NO ADVERSE CONSTRUCTION

These Terms and Conditions are not to be constructed to the disadvantage of the Dealer because the Dealer was responsible for their preparation.

33. SEVERANCE

33.1 If any provision of these Terms and Conditions

- (a) is or becomes void, voidable, illegal or unenforceable in its terms;
- (b) would not be void, voidable, illegal or unenforceable if it were read down; and
- (c) is capable of being read down,

then that provision will be read down accordingly.

33.2 If, notwithstanding clause 33.1, a provision of these Terms and Conditions is still void, voidable, illegal or unenforceable, then:

- (a) if the provision would not be void, voidable, illegal or unenforceable if some words were omitted, those words are severed; and
- (b) otherwise, the whole provision is severed,
- (c) and the rest of these Terms and Conditions will be of full force and effect.

34. ENQUIRIES & PRIVACY

(a) The Purchaser irrevocably authorizes the Dealer, its employees and agents to make such enquiries as it deems necessary to investigate and consider entering into and maintaining an agreement with the Purchaser from time to time including (but without limiting the generality of the foregoing) the making of enquiries of persons nominated as trade referees, the bankers of the Purchaser's any other credit providers (the information sources) and the Purchaser hereby authorizes the information sources to disclose to the Dealer such information concerning the Purchaser which is within their possession and which is requested by the Dealer.

(b) The Purchaser agrees to the Dealer's Privacy Policy, a copy of which is available from the Dealer upon request.

(c) The Dealer recognises the importance of protecting the privacy of the Purchaser. The Dealer is bound by the Privacy Act and the principles thereunder when handling personal information. Further details concerning privacy rights can be found at "The Office of the Australian Information Commissioner" website at <http://www.oaic.gov.au/>.



PERTH

Dealership Reputation

Please see below a list of references for previously supplied machines

Shire of Nungarin

The Shire purchased their Liugong 4230D grader in 2023 through a tender process. They have been very happy with the performance and backup McIntosh & Son have been able to provide and have since bought a Liugong 848H wheel loader and Case TR310B compact track loader. You can read more on this here, <https://www.constructionales.com.au/editorial/details/liugong-graders-hit-the-road-in-wa-144517/#:~:text=Western%20Australia's%20Shire%20of%20Nungarin,roller%20from%20the%20same%20brand.>

Contact: Dave Nayda 08 9046 5521 works@nungarin.wa.gov.au

Shire of Goomalling

In 2023 the Shire purchased a Liugong 862H loader. After testing the machine at our 2023 Liugong Dig & Drive day the Shire works crew were impressed with the build quality, power and controls on the Liugong loaders.

Contact: David Long 0436 813 959 worksmgr@goomalling.wa.gov.au

Shire of Cranbrook

The Shire purchased a Liugong 6524E Multi tire roller in 2024. This was chosen due to the high build quality and reports from surrounding shires and farmers on their Liugong equipment

Contact: Joe Duina 0499 799 133 joe.duina@cranbrook.wa.gov.au

Shire of Woodanilling

The Shire of Woodanilling bought a 6520E multi tire roller early in 2023 and then followed up with a 906E excavator from Liugong later in the year. The Shire has been very impressed with the budget savings and quality of equipment provided from Liugong

Contact: Alan Arnold 0416 185 728 lh@woodanilling.wa.gov.au

City of Swan

2x Rollers

Contact: Sanjeev 0424 815 472 sanjeev-a@swan.wa.gov.au

SCA Earthmoving

In 2022 SCA Earthmoving purchase a Case 836C grader with rear ripper option as an upgrade to their old grader. The machine was demonstrated on site for Charlie and his team and was delivered in 3-4 weeks from order.

Contact: Charlie Guilotto - 0418 953 660

Karoonda Council

Purchased a Case 865B grader for road construction works from our dealer SA Tractors.

Contact: Martin Borgas (CEO) 0468 348 777

Elliston Council

Purchased a Case 865B grader for road construction works from our dealer SA Tractors.

Contact – Tim Mills 08 8687 9177

Mt Remarkable Council

Purchased a Case 865B grader for road construction works from our dealer SA Tractors.

Contact: Michael McCabe – 08 8666 2014

RAM Equipment

RAM equipment recently purchased 2 x Case 865B graders from our dealer SA Tractors. for their equipment hire fleet in South Australia. Operating multiple Case machines in their fleet gave them confidence in the brand to put 2 graders in amongst their John Deere grader fleet.

McINTOSH HOLDINGS PTY LTD (ABN 28 008 675 876 ACN 008 675 876) T/AS McINTOSH & SON WA

Telephone: (08) 9475 1600 Email: perth@mcson.com.au
547 Great Eastern Highway, REDCLIFFE, Western Australia 6104
Fax: (08) 9479 1475 Visit www.mcintoshandson.com.au

Contact: Daniel 0417 026 439

Shire of Perenjori

A new Case 695Sv Backhoe has been recently delivered to the Shire in August 2023. This was spec'd with front and rear quick hitches, 4in1 bucket, forks, and rake grab bucket, and full Shire additions as needed.

Contact: Ken Markham (Works Manager) 0427 731 002

Department of Parks & Wildlife WA

Late in 2022 and 2023 we have delivered 2x Case 590SV backhoes to the Department for works in Busselton and Walpole. Replacing JCB back hoes, the Case was chosen for its stability, operator comfort/visibility, and customer support previously experienced with other product from McIntosh & Son

Contact: Stephen Hebert 0400 910 578

Shire of Manjimup

Early in 2023 a Case 695sv backhoe was purchased to replace a Cat machine for Shire the operations depot in Pemberton. With front and rear quick hitches, equal size tires, and 4-wheel steering, and Shire specifications met.

Contact: Andrew Johns (Works Manager) 0427 472 935

Shire of Esperance

The Shire of Esperance currently operates 3x Case 695 model backhoes across their works department. These were delivered in 2021.

Contact: Paul Farmilio (Fleet Manager) 0437 999 014

Shire of Gnowangerup

The Shire of Gnowangerup currently operates multiple machines from McIntosh & Son. A Case 590ST backhoe, Case 721F wheel loader, and Case TR340 compact track loader.

Contact: Barry Gibbs – barry.gibbs@gnowangerup.wa.gov.au

City of Swan

In February 2023 we were successful in tendering 1x Case 921G Wheel loader & 2x Liugong 6524E Multi tire rollers to the City of Swan. These machines were successfully delivered on time and spec to the Shire early in 2023.

Contact: Sebastian Rosati – Sebastian.rosati@swan.wa.gov.au

Shire of Williams

CASE 721G Wheel loader delivered in 2020

The Shire of Williams tendered for a new wheel loader for roading and general council works. The machine was built with load scales, auto greasing, and a quick hitch, plus general safety additions such as fire extinguishers and beacons.

Contact: Tony Kett (Works Manager) 0419 941 829

Shire of Cranbrook

CASE 721G Wheel loader delivered in 2021

The Shire of Williams tendered for a new wheel loader for roading and general council works. The machine was built with load scales, auto greasing, and a quick hitch, plus general safety additions such as fire extinguishers and beacons.

Contact: Jeff Alderton (Works Manager) 0437 450 147



Engine	Cummins QSL9.3
Rated Power	180 kW (241 hp / 245 ps) @ 2,200 rpm
Blade Width	3,960 mm
Maximum Speed	40 km/h
Draw Bar Pull	93 kN
Operating Weight	17,000 kg

4230D MOTOR GRADER

TOUGH WORLD. TOUGH EQUIPMENT.

4230D SPECIFICATIONS >>>

ENGINE	
Emission Regulation	Tier 3 / Stage III
Make	Cummins
Model	QSL9.3
Rated Power	180 kW (241 hp / 245 ps) @ 2,200 rpm
Maximum Torque	1,187 N·m
Number of Cylinders	6
Aspiration	Turbo & air-to-air intercooled

TRANSMISSION	
Transmission Type	Power shift
Torque Converter	Single stage, three elements
Maximum Travel Speed, fwd	40 km/h
Maximum Travel Speed, rev	26.5 km/h
Number of Speeds, fwd	6
Number of Speeds, rev	3

AXLES	
Differential Type	Limited slip standard
Final Drive Type	Chain drive
Axle Oscillation	16°
Front Axle, Wheel Lean Angle	Left / right 18°

STEERING	
Steering Configuration	Load sensor steering gear
Steering Relief Pressure	16.7 MPa
Minimum Turning Radius	7,200 mm
Steering Angle	±50°
Frame Articulation Angle	±27°

BRAKES	
Service Brake Type	Disc brake
Service Brake Location	Rear axle

TIRES	
Tire Size	17.5-25

HYDRAULIC SYSTEM	
Main Pump Type	Gear
Main Relief Pressure	20 MPa
Main Pump Flow	122 L/min

WORKING CAPACITIES	
Maximum Draw Pull	93 kN
Cutting Pressure	8,050 kg

TANDEM DRIVE PERFORMANCE	
Height	648 mm
Width	226 mm
Center Distance	1,517 mm

MOLDBOARD PERFORMANCE	
Bank Cut Angle	28~74°
Moldboard Lift Above Ground	600 mm
Moldboard Side Shift, left/right	660 / 740 mm
Maximum Sloping Angle	90°
Cutting Depth	680 mm
Circle Rotation	360°
Circle Diameter	1,576 mm
Circle Thickness	150 mm

DIMENSIONS	
Wheelbase	6,230 mm
Overall Length	9,140 mm
Overall Height with Cab	3,380 mm
Clearance under Front Axle	602 mm
Moldboard Standard Length	3,960 mm
Moldboard Standard Thickness	19 mm
Moldboard Standard Height	610 mm

OPERATING WEIGHTS	
Operating Weight	17,000 kg

SERVICE CAPACITIES	
Fuel Tank	348 L
Engine Oil	21 L
Cooling System	35 L
Hydraulic Reservoir	115 L
Transmission and Torque Converter	33 L
Tandems, each	90 L

- | OPTIONAL EQUIPMENT | |
|---------------------------|--|
| Rear Ripper | |
| Front Dozer | |
| Automatic Leveling System | |
| Rotary Beacon | |
| Frictional Flake Worm Box | |

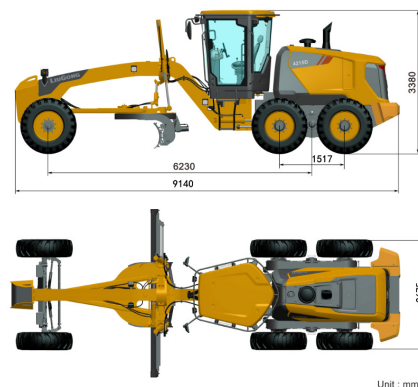

Guangxi Liugong Machinery Co., Ltd.
 No. 1 Liutai Road, Liuzhou, Guangxi 545007, PR China
 T: +86 772 3886124 E: overseas@liugong.com
 www.liugong.com

02/2023 Designed by LiuGong
 Replace the previous versions of 06/2022

Specifications and designs are subject to change without notice. Machines shown may include optional equipment. LiuGong standard and optional equipment may vary from region to region. Please consult your LiuGong dealer for information specific to your area. Engine power kW is converted to horsepower (1 kW=1.3596 ps and 1 kW=1.3410 hp) in this file.

ITEM 15 MATTERS FOR CONSIDERATION - WORK, HEALTH & SAFETY

No matters for consideration

ITEM 16 URGENT COUNCILLOR'S BUSINESS

Nil

ITEM 17 CONFIDENTIAL ITEMS

No matters for consideration

ITEM 18 NEXT MEETING DATE

The next Ordinary Council Meeting is scheduled to take place on Thursday 28 November 2024 commencing at 2.00pm in the Council Chambers, 10 Jennaberring Road, Quairading, WA.

ITEM 19 CLOSURE

There being no further business, the Chairperson closed the Meeting at 2.49 pm.

I certify the minutes of the Ordinary meeting of Council held on 31 October 2024 were confirmed 28 November 2024 as recorded on Resolution No. 072 - 24/25.

Confirmed.....  28.11.2024